

STOVAX



Riva MF Cassette

Installation Instructions

MODELS: RV40/RV55/RV66/RV66AVC

For Use in Great Britain and Eire



This product is suitable for use in the stated countries. To install the product in other countries it is essential to obtain translated instructions and in some cases the product may require modification. Contact Stovax to obtain further information.

IMPORTANT

**Before installation of this product please read these instructions fully.
The installer should complete the commissioning sheet at the start of the User Instructions.**

TECHNICAL SPECIFICATION

RIVA MF: MODELS RV40/RV55/RV66

Model			Riva 40	Riva 55	Riva 66	Riva 66 Avanti
Riva 40-RV 40/RV40B						
Riva 55-RV 55/RV55B						
Riva 66-RV 66/RV66B						
Riva 66 Avanti-RV66AVC						
Nominal Heat Output	Wood	kW	4.9	8	8	8
	Solid Fuel	kW	4.9	8	8	8
Flue Draught at Nominal Heat	All Fuels	mm	1.5	1.5	1.5	1.5
		inch Wg	0.05	0.05	0.05	0.05
Flue Gas Mass Flow	Wood	g/s	5.8	8.3	7.4	7.4
	Solid Fuel	g/s	5.2	9.9	8.1	8.1
Flue Gas Temperature at Spigot/Socket	Wood	°C	444	492	388	388
	Solid Fuel	°C	444	492	388	388
Flue Outlet Size (Top Rear Option)		mm	150	150	150	150
		inch	6	6	6	6

Weight		kg	70	90	101	121
--------	--	----	----	----	-----	-----

Recommended Fuel	Wood	Seasoned wood (less than 20% moisture content)
	Solid Fuel	Briquette smokeless fuel suitable for closed appliances (Ancit - Phurnacite - Taybrite - Homefire ovals)

As tested to the requirements of EN 13229:2001 for intermittent operation

STANDARD FEATURES

- Primary air (under grate air for full multifuel use)
- Airwash (for woodburning/ clean glass)
- Pre-set secondary air control (to ensure complete burning of flue gases)
- Riddling grate system for clean de-ashing
- Stainless steel ashpan
- Removable door handle
- Interchangeable trim / frame options
- Pre-drilled convection air duct connection points (not Riva 40)
- Optional fan convection kit - must be fitted before installation only (not Riva 40)
- Spacer frame kit - to suit 350mm deep opening (Riva 66 only)

PACKING LIST

- User Instructions
- Installer Instructions
- Guarantee card
- Accessory catalogue
- Pair leather stove gloves
- Fixing kit (2 x rawl plugs + 2 x coach screws)
- 2.5mm A/F Hex socket key
- 4mm A/F Hex Socket Key
- 5mm A/F Hex Socket Key
- Door tool
- Riddling tool

SITE REQUIREMENTS

IMPORTANT NOTICE

Before installation of this product please read these instructions fully.

It is very important to understand the requirements of the UK Building Regulations (England and Wales - Document J / Scotland - Part F), as well as any local regulations and working practices that may apply. Should any conflict occur between these instructions and these regulations the regulations shall apply.

All electrical connections should meet the requirements of UK Building Regulations (England and Wales – Document P / Scotland - Part N).

Your local Building Control Office would be happy to advise should questions arise, regarding the requirements of the regulations.

The Riva MF should be fitted by a HETAS (GB only) registered installer, or approved by your local building control officer. Your Stovax dealer should be able to arrange this service for you.

Your building insurance company may also require you to inform them that you have installed a new heating appliance, so check with your insurers that your cover is still valid after installing the Riva MF.

When completing the installation and building works you should comply with your responsibilities under the Health and Safety at Work Acts, and any new legislation which may be introduced during the lifetime of these instructions.

A faulty installation could cause danger to the inhabitants and structure of the building.

RIVA MF CASSETTE DIMENSIONS

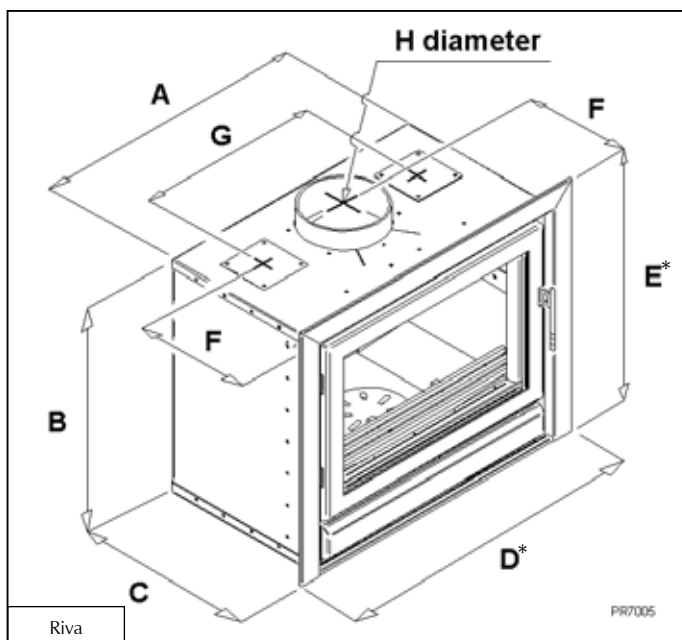

* When fitted with narrow (50mm) trim.

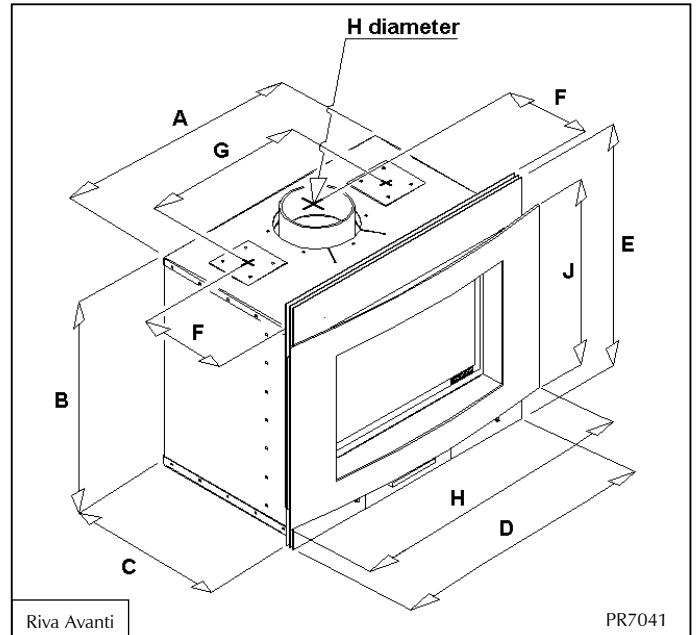

	Riva 40 RV40	Riva 55 RV55	Riva 66 RV66	Riva 66 Avanti RV66 AVC
A	400mm	540mm	650mm	650mm
B	550mm	660mm	550mm	550mm
C	350mm	350mm	395mm	395mm
D	492mm	632mm	742mm	694mm
E	599mm	709mm	599mm	636mm
F	234mm	234mm	248mm	248mm
G	N/A	360mm	420mm	420mm
H	128mm	128mm	153/178mm	153/178mm
J				480mm

SITE REQUIREMENTS

MINIMUM DIMENSIONS BUILDERS OPENING

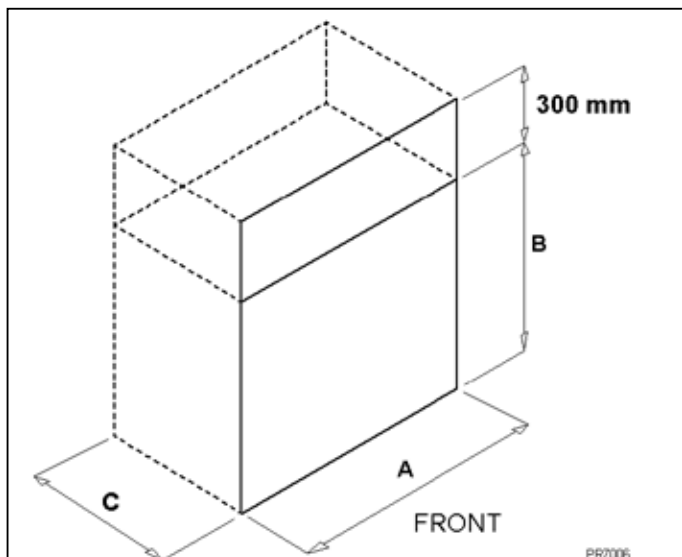

Riva 55/66 only

If optional convection air ducts are to be used, increase the opening height by 300mm to enable connection to be made before final completion of building work.

Riva 66 only

Dimension C may be reduced to 355mm when using the spacer frame kit.

Consideration must be given for the clearance of 20mm between the flue pipe and lintel/inside chimney breast

RIVA MF CASSETTE

	Riva 40 RV40	Riva 55 RV55	Riva 66 RV66	Riva 66 Avanti RV66 AVC
A	410mm	550mm	660mm	660mm
B	560mm	670mm	560mm	560mm
C†	360mm	360mm	405mm*	405mm*

* Riva 66 only

† Dimension C may be reduced to 355mm when using the spacer frame kit.

Stovax Part No.

Riva 66 Profil frame

3 sided Storm - RV66PRO3D / Black - RV66PRO3DB

4 sided Storm - RV66PRO4D / Black - RV66PRO4DB

Riva 66 Avanti - RV66AVSP

Consideration must be given for the clearance of 20mm between the flue pipe and lintel/inside chimney breast.

BUILDERS OPENING

Because each opening is unique to the property, it is not possible to give full details of the construction. However the builders opening should be constructed from non-combustible materials which remain stable at high temperatures, and comply with the requirements of local and national building regulations using “best practice” construction methods. It is possible for the outer casing of the Riva to reach temperatures of 300°C and for the flue to reach higher temperatures.

Remember that many fireplace openings will have supporting lintels. Remove the covering plaster to identify the position of these before starting any construction work. Do not remove constructional lintels without making provision to support the remaining structure of the building. The Riva MF must not form any part of the supporting structure.

The chimney/flue must have a sealed connection to the Riva MF flue spigot.

As the structure of the builders opening will reach high temperatures it is recommended that it is lined with insulating blockwork to reduce the heat transfer to the external walls, in particular the area of the chimney breast above the opening.

Should the finish of the chimney breast and surrounding area be smooth plaster, consideration should be given to the conducted and convected heat emitted by the Riva MF, as this could be high enough to crack normal gypsum based plaster. It is recommended that a high temperature plaster is used, or the area faced with a suitable high temperature plasterboard. New plaster should be fully dried before the Riva MF is used, or cracking could occur.

Due to the high temperature of the convected air above the front of the stove we recommend that no valuable photographs, paintings, porcelain, TV screens or other items are placed on the wall in this area. Such artefacts may be damaged by long term exposure to fluctuating temperatures.

Riva 40 only

It is possible to fit the Riva 40 into an existing, traditional, 16” fireplace opening following the removal of any existing milner fireback. Following the removal of the fireback and any flaunching above, the builders opening should be checked and made good to the dimensions shown in the table. Care should be taken to ensure the existing chimney is in good condition and that it is possible to make the required sealed fluepipe connections to this when the Riva 40 is installed.

If you are in any doubt about your ability to produce a safe opening contact your Stovax dealer for professional advice.

Riva 55/66 only

Should you wish to connect air ducting to the convection system, provision should be made to increase the opening height by an additional 300mm. This will allow the access needed to fit the duct pipes after connecting the flue system.

SITE REQUIREMENTS

Due to the high temperature of the ducts combustible material must be placed no closer than 100mm to the surface. The duct exits and grills must only be placed in a non-combustible wall panel constructed to be stable under high temperatures.

The exit ducts should be placed at high level or protected, as the grill surfaces will become very hot when in use. If the exit is at low level a suitable guard should be used to prevent touching or obstruction. Care should also be taken with the placement of combustible items near the operating duct exit as conducted and radiated heat could cause a fire hazard.

Additional information covering the installation of the Riva MF may be found in the following British Standards:- BS6461, BS6999, and BS8303.

MINIMUM DIMENSIONS - HEARTH

The Riva MF must stand on a constructional hearth with the minimum dimensions as shown in diagram 1. If it is to be fitted in a raised setting consideration may need to be given to extending the depth of the hearth to safely contain any falling logs or embers.

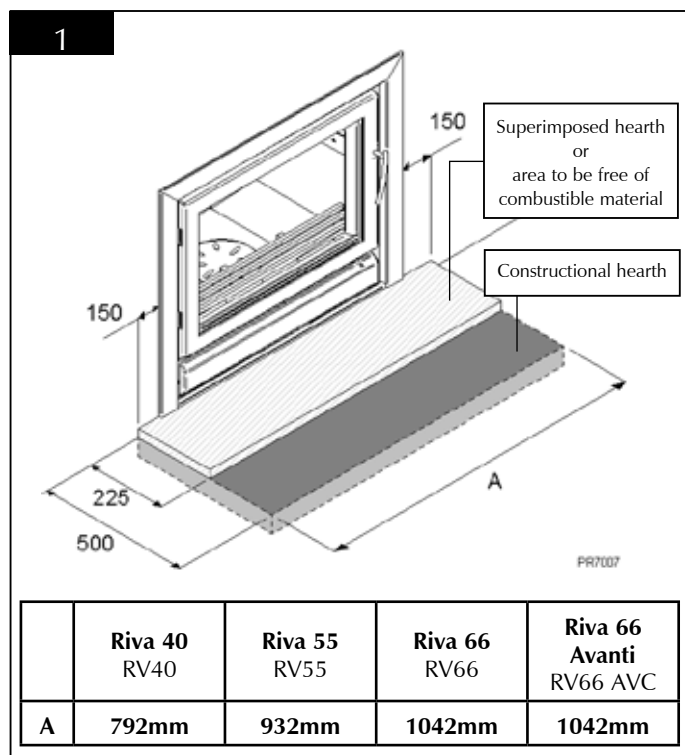

If you are fitting the Riva MF into an existing hearth setting check that it complies with the current regulations and is the minimum size shown.

If you have no existing fireplace or chimney, it is possible to construct a suitable non-combustible housing and hearth setting. However this should be constructed to comply with the requirements of both current national and local regulations and the design approved by your local building control officer. Remember that any new chimney added to your property may also require planning permission.

As some modern houses are built using a timber frame construction with high levels of thermal insulation, consideration must be given to isolating the setting from combustible materials, and providing sufficient air circulation to maintain the heating efficiency.

FIRE SURROUND CLEARANCES

If the Riva MF is to be fitted with a fire surround, we would recommend the minimum clearances, as shown in diagram 2, are maintained between any point of the Riva MF and any combustible material. A selection of surrounds is produced by Stovax and details can be obtained from your local supplier.

We therefore suggest that you obtain expert advice before proceeding with work of this nature.

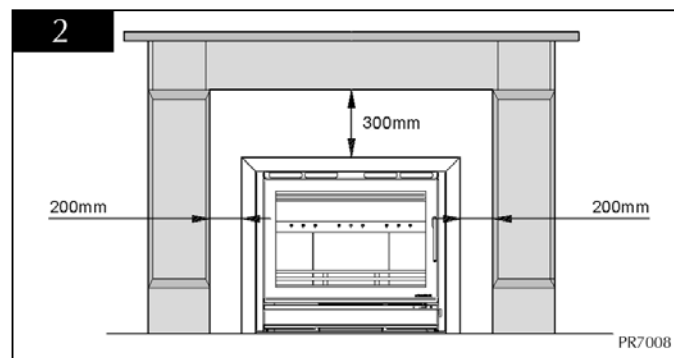

We cannot guarantee that some finishes will not discolour with heat and that some lower quality products will not distort, or crack, when in use.

If stone / granite / marble or any other natural material is used to construct the fire surround, or any part of it, provision should be made for expansion and movement of the parts due to heating and cooling.

If you are in any doubt about the installation requirements, or suitability of fire surrounds contact your Stovax dealer.

All fire surrounds should be suitable for use with solid fuel heating products.

PRE-INSTALLATION CHECKS

It is important that adequate ventilation exists and the flue or chimney system that is to be used is in good working condition. Products of combustion that enter the room could be a serious health risk. Before installation of the Riva MF we recommend that the flue or chimney system and ventilation requirements are inspected by a competent person, and passed as suitable for use with the Riva MF. In particular the following should be checked.

1. FLUE AND CHIMNEY

- 1.1 The Riva MF must be connected to the chimney system and all joints sealed. Failure to do this could result in dangerous fumes entering the building.
- 1.2 The construction of the flue or chimney system should meet the requirements of the Building Regulations with sizes as shown on the next page.

If a suitable approved factory made system is to be used it should be installed to the manufacturers instructions. Do not connect to systems containing large voids of over 230mm square (9" square).

The minimum height of the flue or chimney must be 4m (13') when measured from the hearth to the top of the flue, with no horizontal sections and the maximum of 4 bends with angles of less than 45 degrees.
- 1.3 An approved factory made system suitable for Solid Fuel use, complying with BS 4543: Part 2, may be used when installed to the requirements of BS 7566: Parts 1 to 4, the manufacturer's instructions and the requirements of Building Regulations.
- 1.4 New masonry chimney systems built with clay or concrete liners or pre-fabricated block systems should be constructed in accordance with BS 6461 : Part 1, and the requirements of Building Regulations.
- 1.5 A flexible flue liner system may be used, if it is independently certified for use with solid fuel systems, and is installed according to the manufacturer's instructions and the requirements of Building Regulations. If an appliance is being replaced on an existing flexible flue liner system, the liner system should be replaced, unless it can be proved to be recently installed and can be seen to be in good condition.
- 1.6 The flue exit from the building should be positioned to comply with the requirements of the Building Regulations.

Note: A guide containing general information on Chimneys and Flues is obtainable from: -

The British Flue & Chimney Manufacturers' Association,
FETA
2 Waltham Court, Milley Lane
Hare Hatch
Reading
Berkshire. RG10 9TH
Tel: 0118 9403416 e-mail: info@feta.co.uk

- 1.7 Any existing flue should be confirmed as suitable for the new intended use, as defined in the Building Regulations.
- 1.8 Any existing flue or chimney system must be inspected and swept by a NACS registered (UK only) chimney sweep, to confirm that the system is structurally sound and free from any obstructions.
- 1.9 Suitable access should be provided to enable the collection and removal of debris.
- 1.10 Provision should be made to sweep and inspect the flue when the appliance is installed.
- 1.11 No other heating appliances should be connected to, or share, the same flue or chimney system.
- 1.12 Check the flue draught. This should be done with all windows and doors closed and any extraction fans in this or adjoining rooms running at maximum speed. (See next section for additional ventilation requirements)

MAXIMUM DRAUGHT - 2.5mm WG

MINIMUM DRAUGHT - 1.0mm WG

- 1.13 Where a hearth, fireplace, flue or chimney is provided or extended (including cases where a flue is provided as part of refurbishment work), information essential to the correct appliance and use of these should be permanently posted in the building, to meet Requirement J4 of the Building Regulations (England and Wales), F3.12 (Scotland).

PRE-INSTALLATION CHECKS

Model			Riva 40	Riva 55	Riva 66	Riva 66 Avanti
Riva 40-RV 40/RV40B						
Riva 55-RV 55/RV55B						
Riva 66-RV 66/RV66B						
Riva 66 Avanti-RV66 AVC						
Flue/Chimney Size	Without Liner System Round (diameter)	mm	150	150	150	150
		inch	6	6	6	6
	Without Liner System (square) Minimum Dimension	mm	135	135	135	135
		inch	5½	5½	5½	5½
	Liner or Factory Made System (diameter) installed in accordance with manufacturers instructions	mm	†150	150	150	150
		inch	†6	6	6	6

Flue/Chimney minimum height*	All Products	m	4	4	4	4
		feet	13	13	13	13

* When measured from the top of the stove to the top of the flue, with no horizontal sections and a maximum of 4 bends with angles of less than 45°

†May be 125mm (5") if only burning low volatiles (smokeless) fuels approved for use in Smoke Control Areas. See web site <http://uksmokecontrolareas.co.uk> for more information about approved fuels.

2. ADDITIONAL VENTILATION

2.1 Additional ventilation will be required to comply with the requirements of the Building Regulations. This should be provided using a permanently open air vent, of the size listed, which is positioned so that it is not liable to be blocked both inside and outside the building.

2.2 Extractor fans or cooker hoods should not be placed in the same room or space as the appliance.

2.3 **If any of these checks reveal problems do not proceed with the fitting of the appliance until they have been rectified.**

Model		Riva 40	Riva 55	Riva 66	Riva 66 Avanti
Riva 40-RV 40/RV40B					
Riva 55-RV 55/RV55B					
Riva 66-RV 66/RV66B					
Riva 66 Avanti-RV66 AVC					
Additional Ventilation	mm ²	NONE	1650mm ²	1650mm ²	1650mm ²
	cm ²	NONE	16.5cm ²	16.5cm ²	16.5cm ²
	in ²	NONE	2.56in ²	2.56in ²	2.56in ²

INSTALLATION INSTRUCTIONS

To make the fitting of the Riva MF easier, gain better access to the flue connection and protect paintwork from damage, remove the internal components. The ashpit door, door and the front trim may be removed on Riva products.

1. DOOR REMOVAL (RIVA)

(Tools required – None)

- 1.1 Remove the door from the Riva MF, by opening the door by approximately 25mm and lifting the door free of the hinge blocks on the left of the door. Then lie the door face down on a soft flat surface, to protect the paintwork and glass.
- 1.2 Take care to protect the top left hand corner of the door to avoid damage to the paintwork.

2. ASHPAN DOOR REMOVAL (RIVA)

(Tools required – 2.5mm A/F Hex socket key)

- 2.1 Remove the ashpan door from the appliance, as shown in diagram 1, by lowering the door to expose the hinge fixing screws (2 each hinge). Remove the fixing screws and lift the ashpit door clear of the appliance.

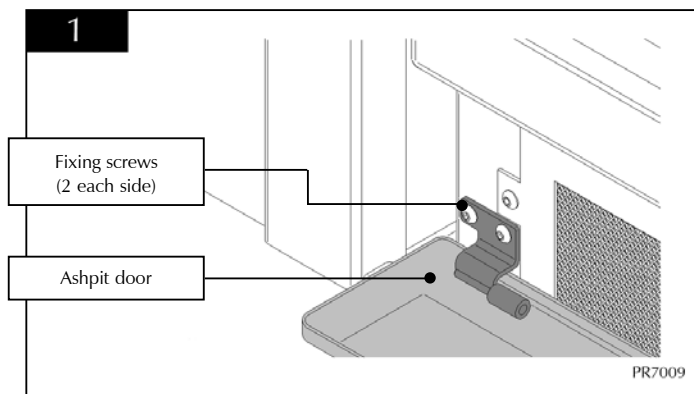

- 2.2 The replacement of the system is the reverse of the previous operations.

3. BAFFLE REMOVAL (ALL)

(Tools required – None)

The Riva MF is fitted with a twin baffle system, consisting of upper and lower baffles. See diagram 2.

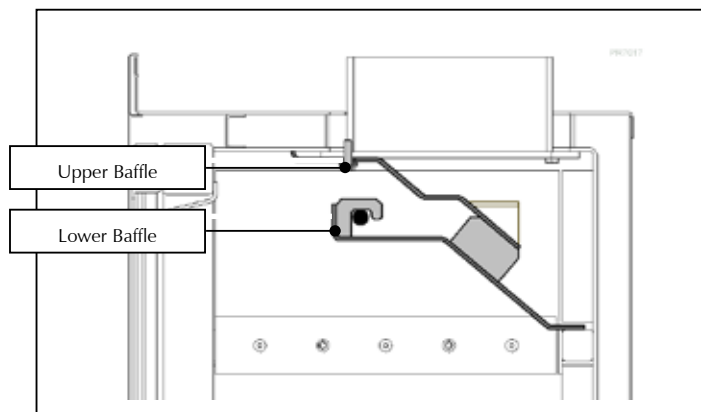

- 3.1 To remove the baffle system, first remove the log guard from the Riva MF to give access to the firebox.
- 3.2 **First** remove the **Lower Baffle**, see diagram 3, by lifting the front edge to unhook it from the support bars, then pull the baffle forward to disengage the rear edge from the location above air inlet holes. Rotate the baffle to remove from the firebox through the door opening.

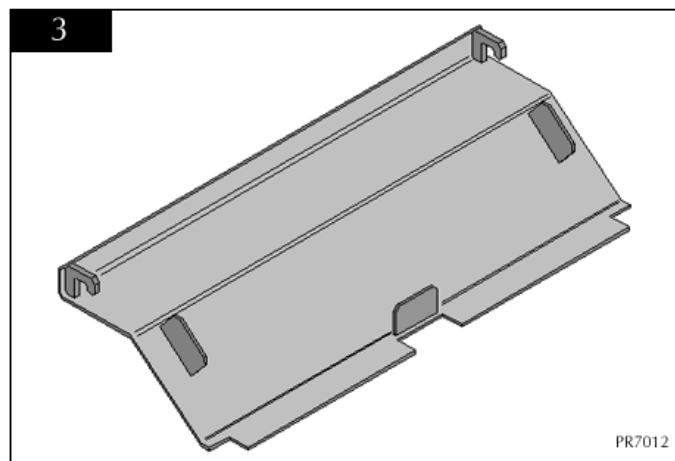

- 3.3 **Second** remove the **Upper Baffle**, see diagram 4, by pulling forward to disengage it from the hanging points at the top of the firebox. Rotate the baffle to remove from the firebox through the door opening.

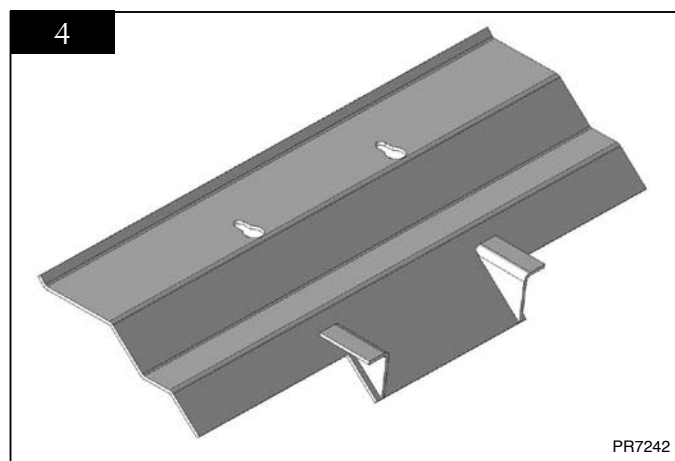

INSTALLATION INSTRUCTIONS

3.4 The replacement of the system is the reverse of the previous operations.

Do not modify the baffle

4A. FIREGRATE REMOVAL (RIVA)

4a.1 To remove grate, first remove the centre grate by tipping the grate control boss downwards and lifting the centre grate vertically.

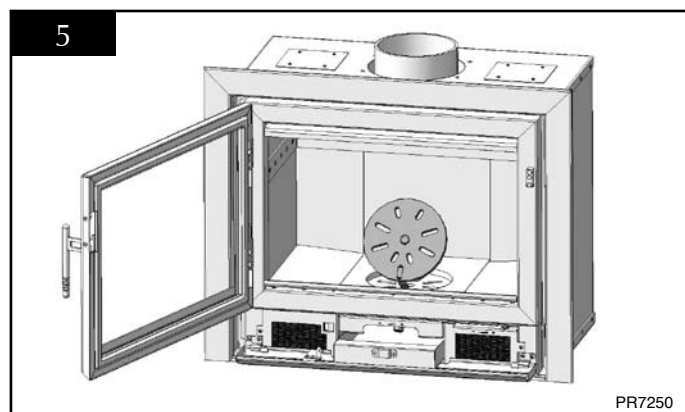

4a.2 The main grate can then be lifted by the front first and then rotating the main grate to clear the firebox.

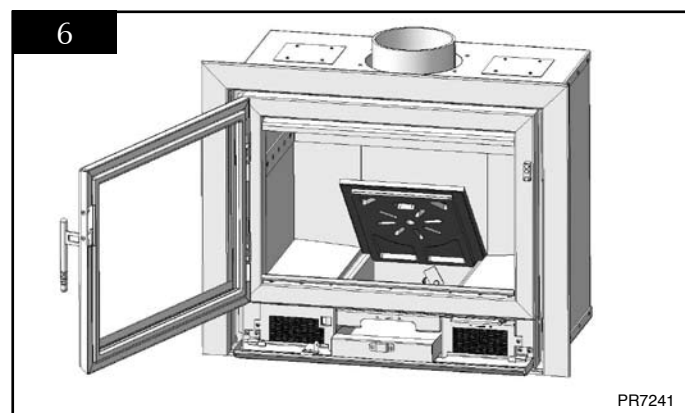

4a.3 Ensure that the seal tape on the underside of the grate is in good condition and correctly fitted. If not, replace with new. (Stovax part number 4998)

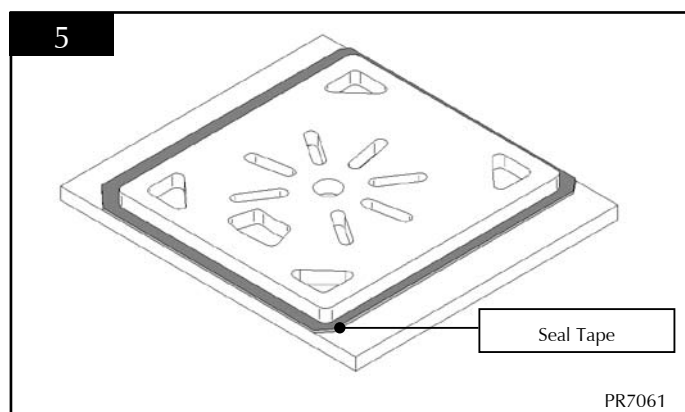

4a.4 Replace the grate in the reverse order from removal.

4a.5 Ensure that the grate sits flat on the side supports, and that no debris are trapped under it. Check also that the centre grate sits flat and rotates freely with no debris trapped under it.

4B. FIREGRATE REMOVAL (RIVA AVANTI)

(Tools required – None)

4b.1 To remove the firegrate, first remove the centre grate. To do this disconnect the operating linkage from the grate. Moving the Primary air control to the fully open position, then springing the operating link forward to disconnect the balljoint does this. The centre grate can then be lifted out from inside of the firebox.

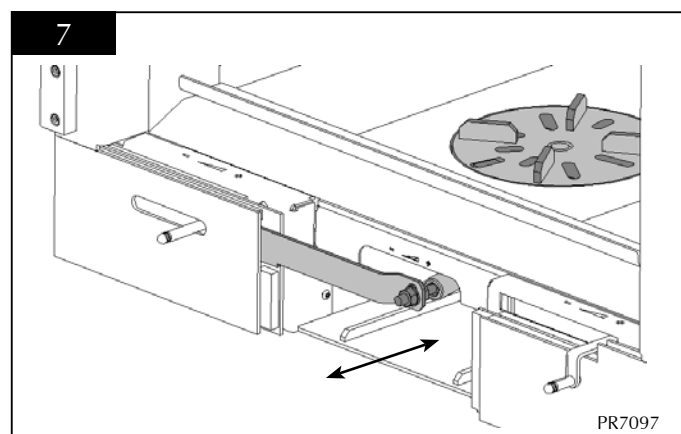

4b.2 The main grate can then be lifted out of the firebox.

4b.3 Replace the grate system in the reverse order from removal.

4b.4 Ensure that the seal tape on the underside of the grate is in good condition and correctly fitted. If not replace with new. (Stovax part number 4998)

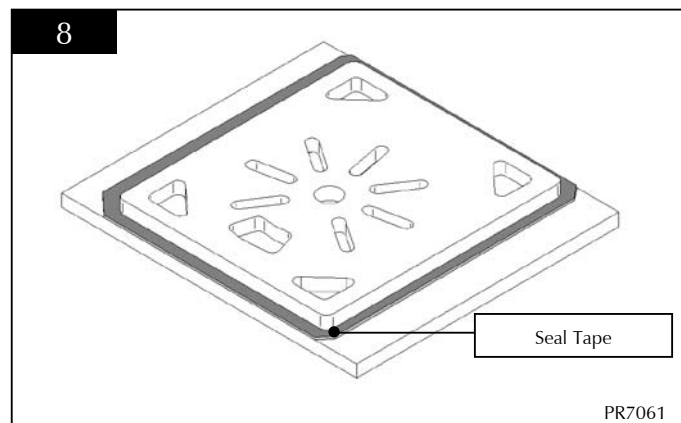

4b.5 Ensure that the grate sits flat on to the side supports, and that no debris are trapped under it. Check also that the centre grate sits flat and rotates freely with no debris trapped under it.

INSTALLATION INSTRUCTIONS

5. BRICK REMOVAL (ALL)

(Tools required – None)

- 5.1 The bricks must be removed and replaced in the correct order, as shown in diagram 8, after removing the baffles and grate system.

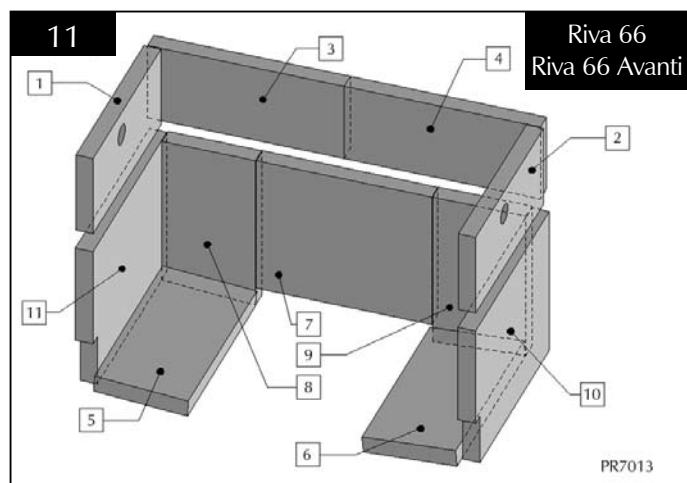
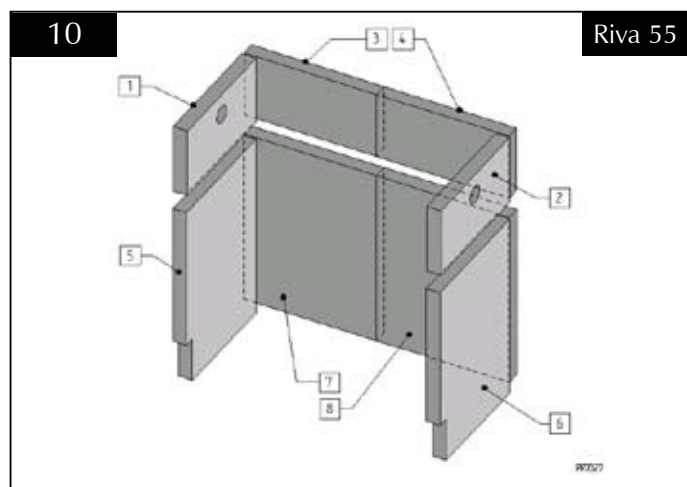
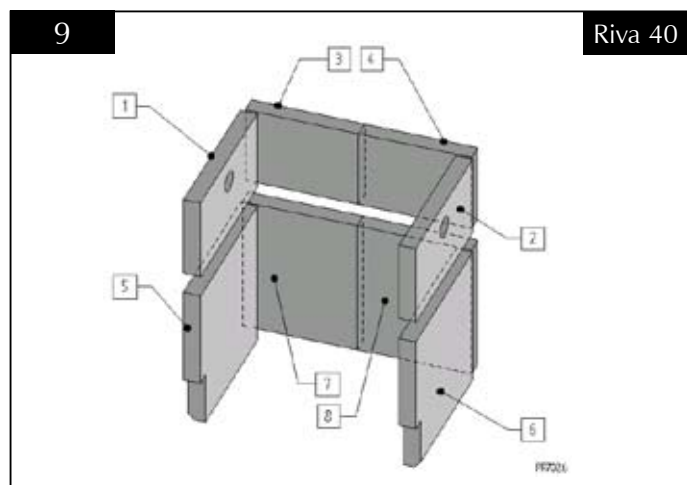

- 5.2 Replace the bricks in the reverse order from removal.

Because each installation is unique to the property, it is not possible to give full details to suit every setting. However the installation should comply with the requirements of the Building Regulations and be made using "best practice" construction methods

Remember that many fireplace openings will have a supporting lintel. Do not remove this without making provision to support the remaining structure of the building. **The Riva cassette must not form any part of the supporting structure or support the full flue system.**

6. INSTALLING THE APPLIANCE (ALL)

- 6.1 Slide the Riva MF into the opening, taking care not to damage the hearth.

(Riva Only)

- 6.2 If the Riva MF is to be fitted with a 4 sided frame, fit the frame as detailed in section 7 before fixing the appliance in to position.

(Riva Only)

- 6.3 Check the fit of all frame options detailed in section 7 before fixing the appliance into position. **Some installations may require the frame to be fitted before final fixing.**

- 6.4 When the Riva MF is in position it must be fixed into place using fixing holes located under the ashpan. See diagram 9. Only fix using the fixing kit provided. (Tools required 10mm A/F spanner /socket wrench and masonry drill) Ensure that the flange of the Riva MF is still flat against the opening after tightening the fixing screws.

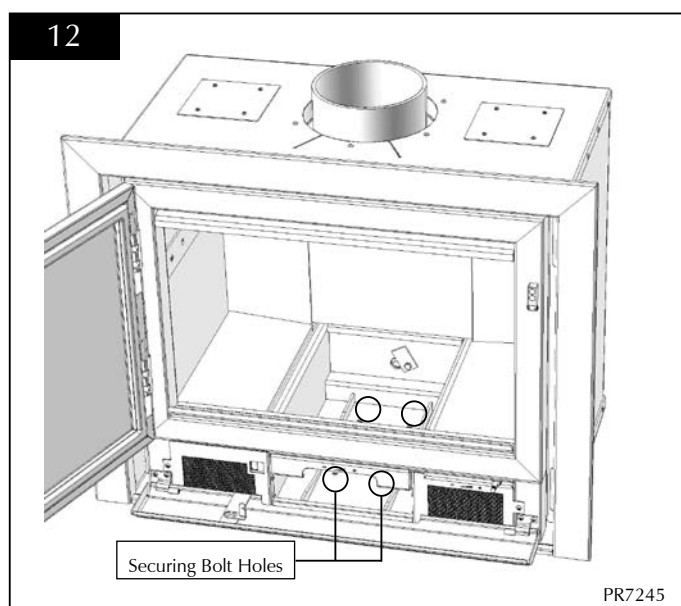

INSTALLATION INSTRUCTIONS

- 6.5 If there is a void at the back or sides of the box this may be filled with 6:1 vermiculite / cement mix or any other good quality non-combustible insulation material. It is important that the back and sides of the box are well insulated.
- 6.6 Connect the flue liner and flue adaptor to the Riva MF by inserting the flue spigot from the inside of the Riva MF and sliding the flue pipe or liner adaptor inside of the spigot. Ensure that the flue is sealed to the spigot using fire cement. Also that the spigot is sealed to the inside of the Riva MF using fire cement. See diagrams 13, 14, 15.

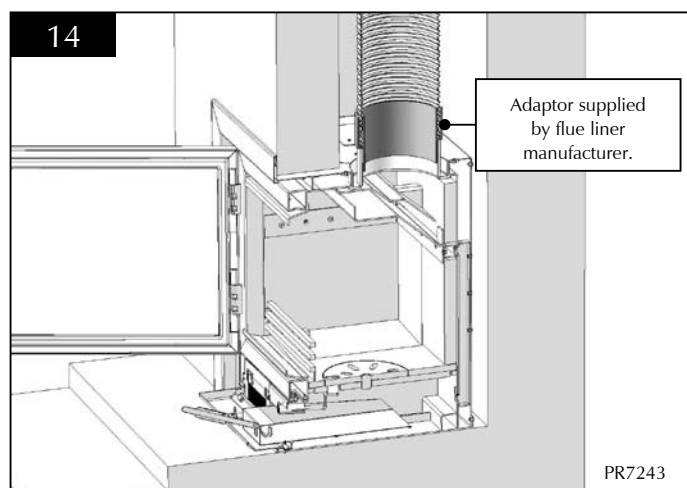
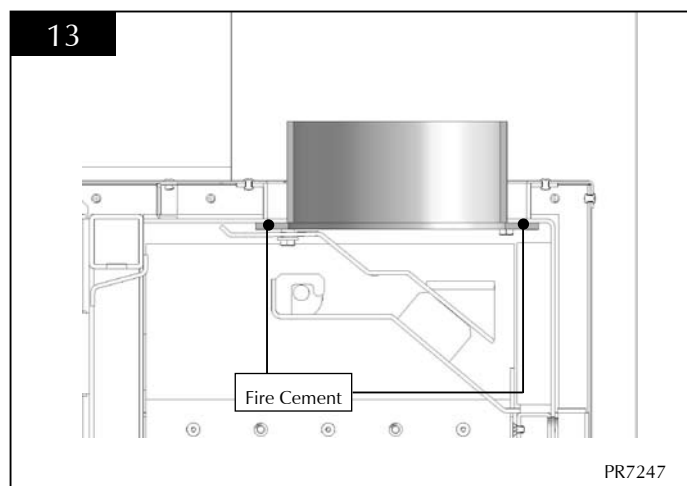

- 6.7 Should the Riva MF be installed on an unlined, masonry flue, first fit a non-combustible closure plate to locate the first section of single wall flue pipe from the Riva MF to the old system. Then make the connection as with a flue liner system. Do not connect the system into large voids that could exist in older chimney systems. If this is the case consider using a flue lining system to improve the Riva MF operation. See diagram 15.

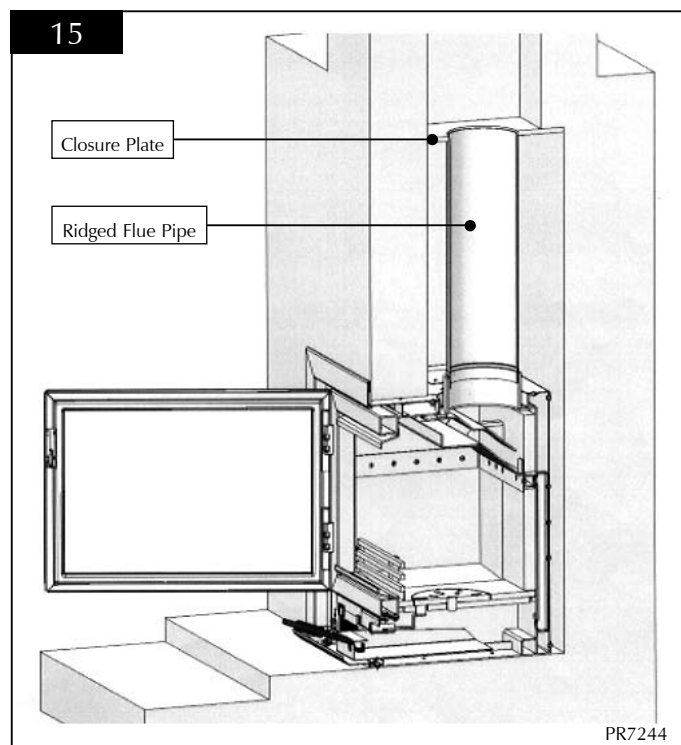

7. FITTING THE FRAME (RIVA)

(3 sided 'Profil' frame shown)
(Tools required – 2.5mm A/F Hex socket key)

- 7.1 The frame is in 2 parts, the lower frame and the main 3 sided section. To fit the frame, locate the main frame on the top clips on the firebox. See diagram 13.

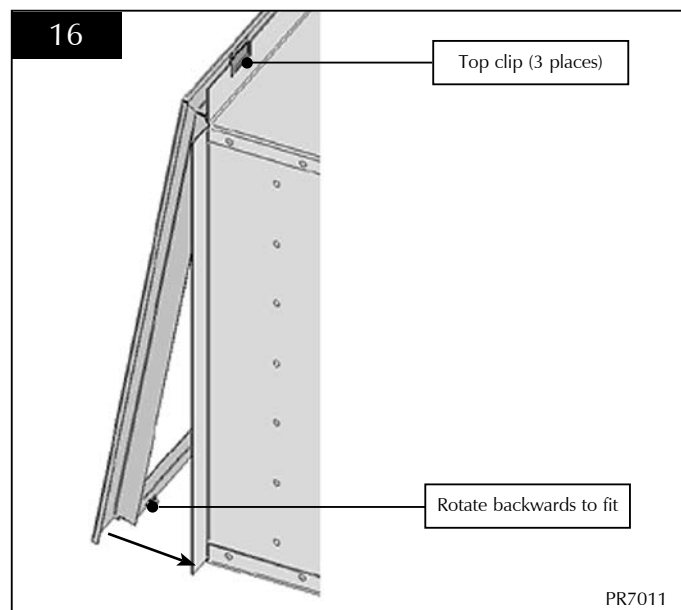

- 7.2 The main frame can now be rotated into position on the front of the appliance body and fixed in place with the trim fixing screws.

INSTALLATION INSTRUCTIONS

- 7.3 Finally fix the lower frame into position using the two fixing screws supplied. See diagram 17.
- 7.4 The removal of the frame is the reverse of the previous operations.
- 7.5 Protect the Riva MF paintwork from possible damage and marking from building debris during installation.

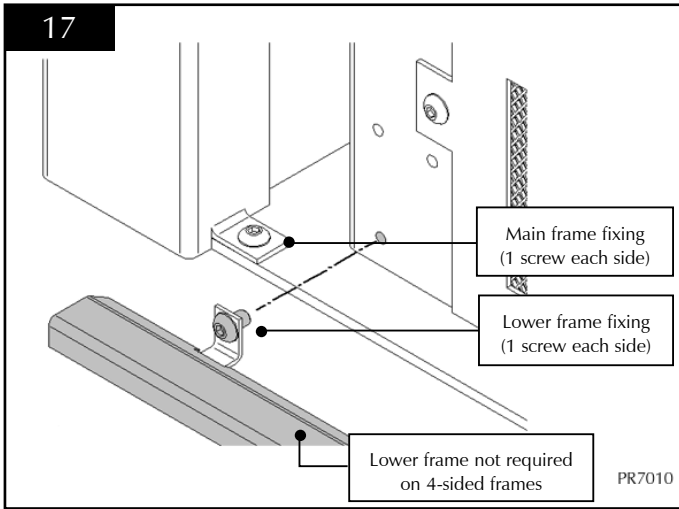

8. FITTING CONVECTION AIR DUCTS

Riva 55/66/66 Avanti Only

Convection air may be ducted from the Riva MF to distribute warm air to other parts of the building. The distance this air may be ducted, and the position of the ducts will depend on the layout of the property.

A convection air ducting kit can be purchased from your Stovax dealer (Stovax part number 8572), as shown in diagram 18.

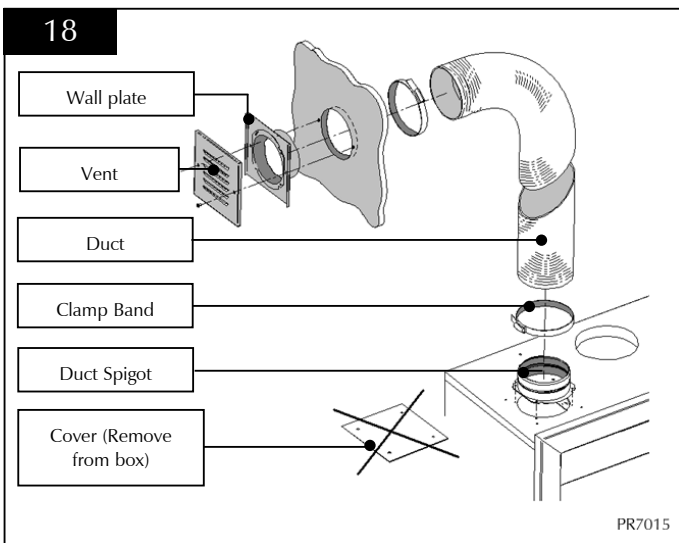

- 8.1 The ducts can be fitted by removing the cover plates on the top of the firebox, by drilling out the fixing rivets and fitting the duct spigots with either pop rivets or self-tapping screws. Fit and seal ducting to the spigots.
- 8.2 **Due to the high temperature of the ducts combustible material must be placed no closer than 100mm to the surface. The duct exits and grills must only be placed in a non-combustible wall panel.**
- 8.3 The exit ducts should be placed at high level or protected, as the grill surfaces will become very hot when in use. If the exit is at low level a suitable guard should be used to prevent touching or obstruction. Care should also be taken with the placement of combustible items near the operating duct exit as conducted and radiated heat could cause a fire hazard.
- 8.4 Following completion of the fitting of the ducts replace and finish the final 300mm of masonry above the front of the Riva MF. See diagram 19.

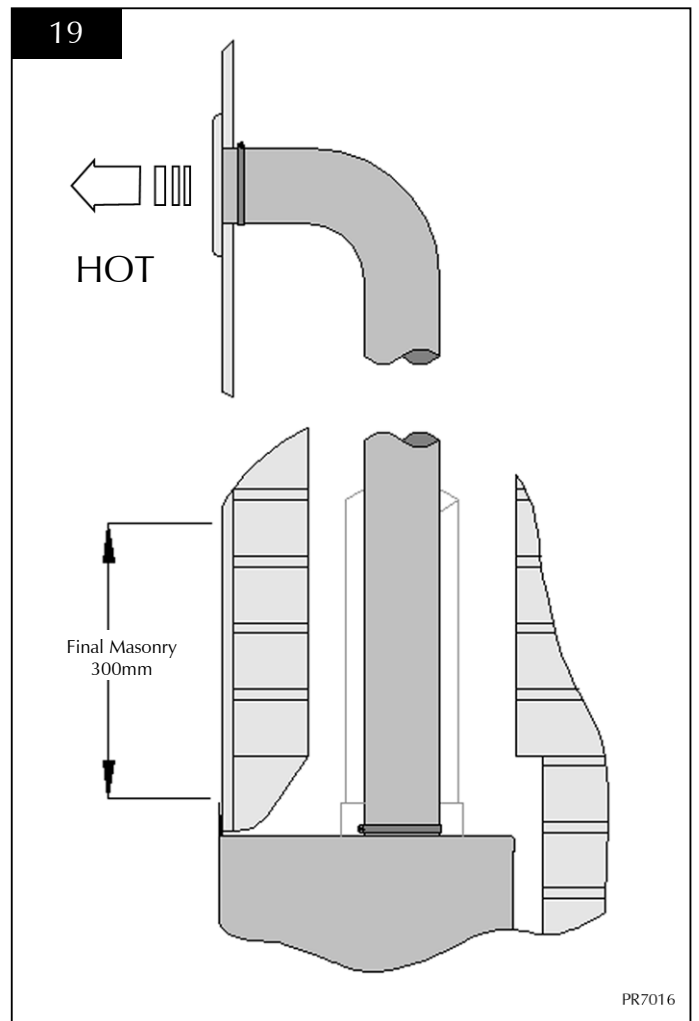

COMMISSIONING

- 1.1 Replace the firegrate, firebricks, baffles, log retainer, door and front trim. Check the door alignment and catch operation, adjust if required as detailed on page 14 of the Users Instructions. Inspect the door seals for damage and check the operation of the air controls.
- 1.2 Carry out a final smoke draw test on the installed Riva MF, by first warming the flue with a blow-lamp, or similar, for about 10 minutes. Then place a smoke pellet on the centre of the grate, with the air controls open, and close the door. Smoke should now be drawn up the flue and be seen to discharge at the terminal. This test should be completed with all doors and windows in the room where the Riva MF is fitted closed. Should this test fail the suitability of the flue system should be re-checked.
- 1.3 Light the Riva MF and gently allow the temperature to increase slowly to operating levels. Check that no combustion products are entering the room. When the Riva MF has reached a steady operating condition open the main fire door and carry out a spillage test with a smoke match or pellet around the door opening. If excessive spillage does occur allow the Riva MF to cool and re-check the suitability of the flue system.
- 1.4 An inadequate air supply to the room in which the Riva MF is installed could lead to the escape of flue gasses, which is very dangerous.
- 1.5 **Explain the safe operation of the Riva MF and the use of the controls to the user, along with the need to only use suitable fuels. Also explain the cleaning and routine maintenance requirements.**
- 1.6 **Explain the requirement to use a suitable fireguard when children, elderly or infirm persons may be near the Riva MF.**
- 1.7 **Record dealer/supplier details and installer details in user instructions.**
- 1.8 **Record serial number in user instructions.**
This number will be required when ordering spare parts or making any warranty claims.

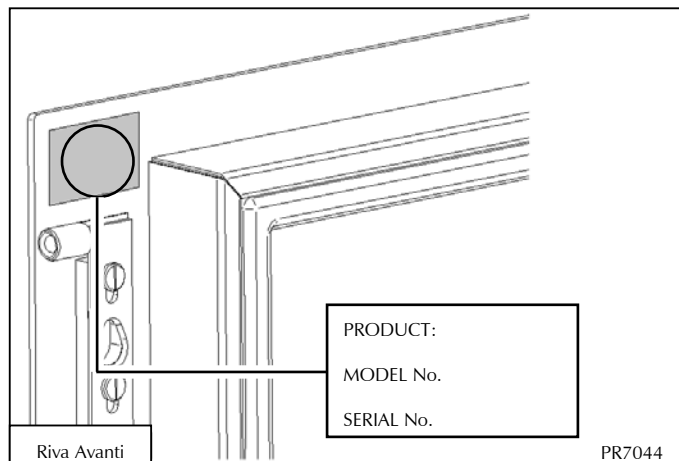
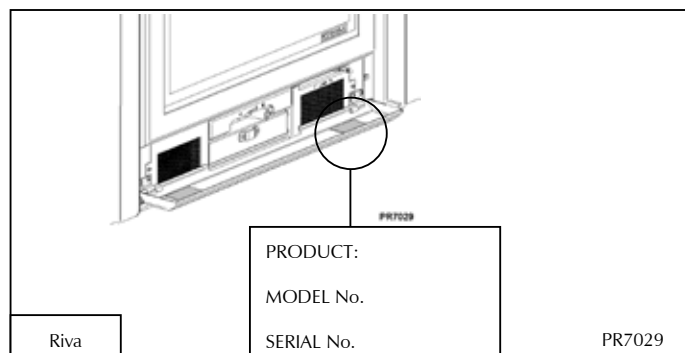

- 1.9 **Give the copy of the user instructions to the customer.**

NOTES

NOTES

Stovax Ltd, Falcon Road, Sowton Industrial Estate, Exeter, Devon, England EX2 7LF
Tel: (01392) 474011 Fax: (01392) 219932 E-mail: info@stovax.com www.stovax.com