



HERALD 6 GAS STOVE

Installation and Servicing Instructions

Please leave this instruction booklet with the user after the installation is complete. Leave the system ready for operation and instruct the user in the correct use of the appliance and operation of its controls.

Please refer to the appliance data plate for the specific model type.

Contents

TECHNICAL DATA	3
STOVE DIMENSIONS.....	3
INSTALLING THE APPLIANCE	4
PRE-INSTALLATION NOTES.....	4
FLUE ARRANGEMENT.....	5
ADDITIONAL AIR VENTING (GB ONLY).....	5
REMOVING THE STOVE BODY	6
<i>Removing the Cast Iron Doors</i>	<i>6</i>
<i>Removing the Stove Body</i>	<i>6</i>
GAS SUPPLY CONNECTIONS.....	7
TESTING SUPPLY PRESSURE.....	7
INSTALLATION OF THE FIRE-BED INTO THE STOVE.....	8
FIRE-BED ARRANGEMENT.....	8
<i>Section A - Fitting the Coal Effect Ceramic Matrices.....</i>	<i>9</i>
<i>Fitting the Loose Ceramic Coals</i>	<i>10</i>
<i>Section B - Fitting the Log Effect Ceramic Matrices</i>	<i>11</i>
<i>Fitting the Loose Ceramic Logs</i>	<i>12</i>
FITTING THE CANOPY – (OPTIONAL)	14
SPILLAGE MONITORING SYSTEM	15
FITTING THE REMOTE CONTROL (OPTIONAL)	15
<i>Fitting the Motor to the Valve</i>	<i>15</i>
<i>Attaching the Remote Control Receiver Box</i>	<i>16</i>
SERVICING INSTRUCTIONS.....	17

Please read these instructions carefully

It is important that your stove is correctly installed as Hunter Stoves Limited cannot accept responsibility for any fault arising through incorrect installation.

TECHNICAL DATA

	NATURAL GAS	LPG
Nominal Gas Pressure	20mBar	37mBar
Supply Gas Type/Category	G20/I _{2H}	G31/I _{3P}
Jet Type/Size	82/380	92/190
Heat Input (Gross) Full Low	6.5kW 4.2kW	6.4 kW 3.7 kW
Gas Flow Rate (m ³ /h) Full	0.62 m ³ /h	0.236 m ³ /h
NO _x Class	3	5
Efficiency Class	2	2
Countries of Destination	GB & IE Only	GB & IE Only

Stove Dimensions

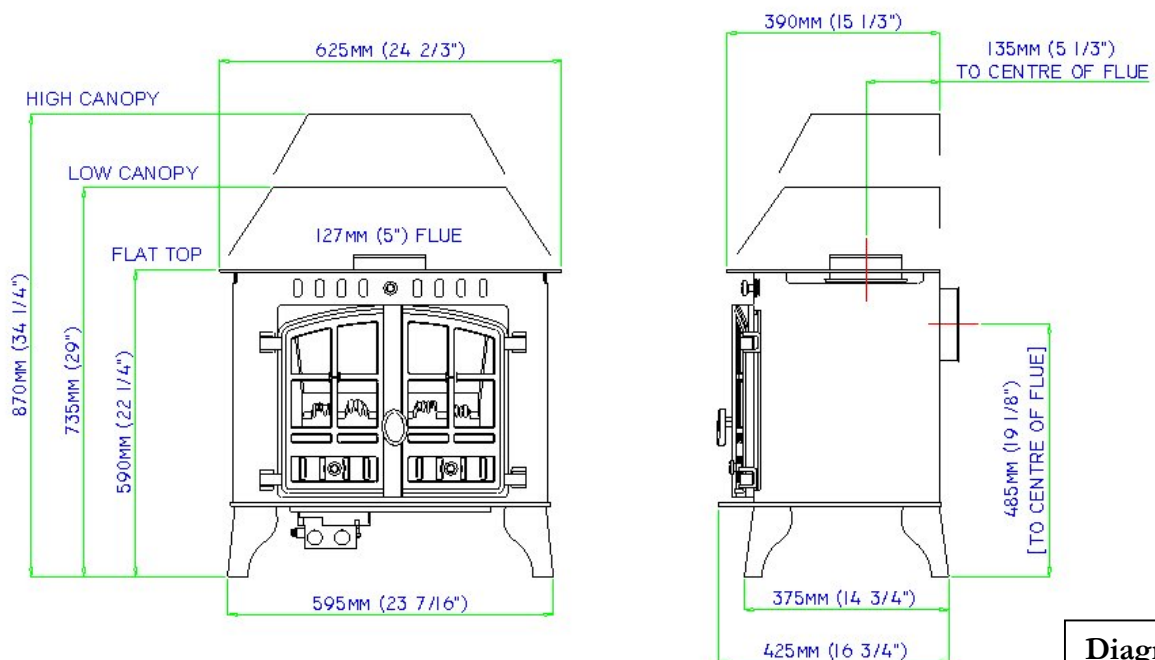

Diagram 1

INSTALLING THE APPLIANCE

Pre-installation notes

1. Check the stove data plate to establish the gas type required. The data plate can be found on a chain at the top left rear corner of the stove.
Before installation check that the local distribution conditions, nature of the gas and pressure, and adjustment of the application are compatible.
2. A **CORGI REGISTERED INSTALLER** or equally recognised competent person must fit the appliance. That person is legally responsible for the safe installation of the appliance with due regard to all relevant local and national building regulations.
3. All outer surfaces of the stove excepting the gas control knobs are defined as working surfaces.
4. **Installation site**
Any installation area previously used for a solid fuel fire or stove would probably be deemed suitable for the appliance.
5. **The stove must not be installed onto a combustible wall. Any combustible materials must be removed from behind the appliance.**
1. The appliance must be sited on a non-combustible hearth of minimum 12mm thickness.
7. The hearth should be edged or raised to prevent combustible floor finishes (e.g. Carpet) from being laid too close to the appliance.
8. **Opening Clearances**
For the relevant clearance distances for installing the appliance in an opening see diagram 2 below:

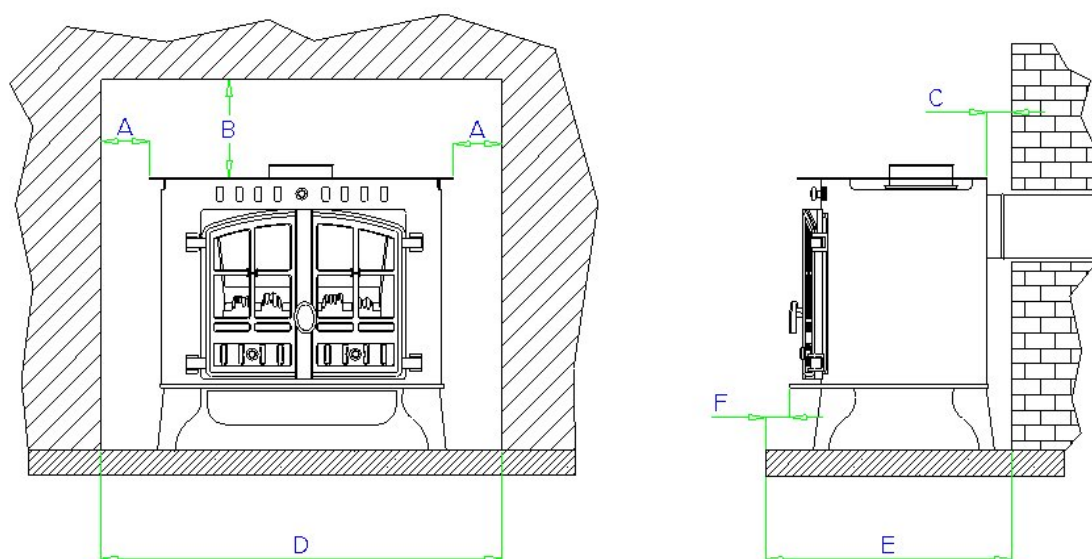

Diagram 2

Clearance Distances for Diagram 2

	DIMENSION DESCRIPTION	MINIMUM CLEARANCE DISTANCES TO:	
		COMBUSTIBLE MATERIAL	NON-COMBUSTIBLE MATERIAL
A	Edge of stove top to wall	100mm	50mm
B	Top of stove to underside of opening	300mm	200mm
C	Rear of stove to wall	N/A	50mm
D	Minimum fireplace opening/Hearth dimension	825mm	775mm
E	Minimum hearth depth	525mm	525mm
F	Minimum distance for hearth to extend in front of stove	50mm	50mm

IMPORTANT NOTE! Adequate clearance must be given between the appliance and the walls so that a satisfactory spillage test can be performed as detailed on page 15.

Flue Arrangement

The CORGI REGISTERED ENGINEER commissioned to install this appliance is wholly responsible for deciding the suitability of any flue arrangement to operate in conjunction with this gas appliance.

The chimney or flue system that is to be fitted to the Herald 6 gas stove must comply with the current rules in force.

(The Herald 6 gas stove is also suitable for other specific class 2 installation arrangements: pre-cast flues, ridge-vent flues and pre-cast chimney block and with the relevant adaption, the appliance will operate in a closure plate type system.)

It is suggested to run flue pipe at least 615mm vertically from the unit before there are any changes in direction of the flue system. Wherever possible horizontal runs of the flue system should be avoided.

It is suggested that the flue has a minimum of 3 meters of vertical height. Please note for rear flue appliances it is recommended that the vertical flue run be established as soon as is practical from the rear flue exit. (Caution should be taken locating the exit of the flue as explained in 'The Building Regulations - Document J'.)

Before commencing any installation work the installing engineer must check that the flue is free from all blockages, the chimney should be given a precautionary clean, and finally the chimney should be smoke tested to ensure soundness. Additionally any flue dampers must be permanently fixed open or removed altogether.

Additional Air Venting (GB Only)

The supply gas heat input into the appliance is nominally less than 7kw, therefore under the directives of the current gas safety and use regulations (1995) No additional air vents are required in the room the appliance is situated.

Removing the Stove Body

THE BODY OF THE STOVE IS HEAVY! To reduce weight it is recommended that the cast iron doors be removed before attempting to remove the stove body.



Diagram 3

Removing the Cast Iron Doors

Open the right-hand door. While holding the door with one hand, gently push up the two hinge pins (Top and bottom) with the other hand. Remove the hinge pins and the door can then be removed. Carry out the same process for the left-hand door.

Removing the Stove Body

The stove body is secured in place by four 13mm bolts. Two of the bolts are located just inside the door opening (Diagram 4) and two at the back of the stove (Diagram 14 – Page 14). Slacken the rear bolts using a 13mm socket/spanner and remove the front bolts (Diagram 4). Gently pull the body forward. The body can then be lifted away from the stove.



Diagram 4



Diagram 5

Removing the Glass

The glass is held in place by 4 fixing clips, 2 at the top and 2 at the bottom. Slightly slacken the lower two fixing screws with a flat blade screwdriver. There is no need to fully remove the screws. Holding the glass with one hand, as shown in diagram 5, slacken the top 2 fixing screws until the clips have moved away from the glass panel. The glass panel can then be lifted out.

Gas Supply Connections

The appliance is supplied with a 8mm Bundy pipe and a 8mm compression elbow to allow easy connection to the mains gas supply. This supply gas pipe should incorporate a gas service isolation tap that is situated within 1 metre of the application.

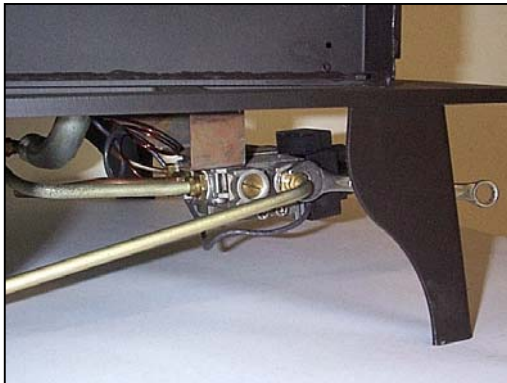

Diagram 6 shows the 8mm Bundy pipe being fitted to the gas inlet on the valve. The compression joint is tightened with a 12mm open-ended spanner.

Diagram 6

Testing Supply Pressure

1. Gas pressure at the appliance is measured via the rearward test nipple (Test nipple 'A' in diagram 7) on the left-hand side of the control valve. (Turning the screw approximately half a turn anti-clockwise with a small flat-bladed screwdriver opens the test point.)

ALWAYS CLOSE TEST POINTS AFTER USE!

2. The gas pressure at the appliance is measured with the appliance running at **full rate**. (For information on how to achieve 'full rate' read 'Adjusting Between High and Low Output Settings' in the 'Lighting the Appliance' section of the User Instructions.)

Burner Gas Pressure should be:

Natural Gas @ 19mBars

LPG @ 36mBars

3. The supply pressure coming into the appliance can also be checked by using test point 'B', shown in diagram 7.

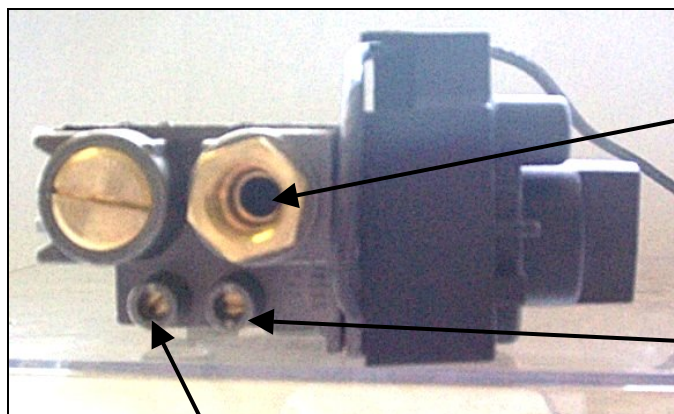

**Gas Supply Connection
(8mm Compression Fitting)**

**Mains/Supply
Pressure Test Point
(Test Point 'B')**

**Burner Pressure Test Point
(Test Point 'A')**

Diagram 7

INSTALLATION OF THE FIRE-BED INTO THE STOVE

IMPORTANT NOTE!!

CERAMIC COALS AND LOGS GET VERY HOT! NEVER ATTEMPT TO HANDLE HOT COALS OR LOGS WITH BARE HANDS AND NEVER PLACE HOT COALS OR LOGS ON OR NEAR COMBUSTIBLE SURFACES.

NO RESPONSIBILITY FOR ANY INJURY HOWEVER CAUSED WHILST HANDLING HOT COALS, LOGS OR CERAMICS CAN BE ACCEPTED BY HUNTER STOVES LTD.

FIRE-BED ARRANGEMENT

This appliance can be fitted with either 'coal effect' or 'log effect' ceramics.

If you are fitting 'Coal Effect' ceramics please follow the instructions set out in 'Section A – Fitting the Coal Effect Ceramic Matrices' (Page 9).

If you are fitting 'Log Effect' ceramics please skip 'Section A' and follow the instructions set out in 'Section B – Fitting the Log Effect Ceramic Matrices' (Page 11).

Section A - Fitting the Coal Effect Ceramic Matrices

NATURAL GAS: The fire-bed is constructed of 3 ceramic matrices, 4 small coals, 10 medium coals and 4 large 'diamond shaped' coals.

LPG: The fire-bed is constructed of 3 ceramic matrices, 10 small coals, 4 medium coals and 4 large 'diamond shaped' coals.



Diagram A8

1. Place the rear ceramic matrix into the fire. The ceramic should sit on the burner tray top and be placed so that it touches the back of the firebox. As shown in Diagram A8.

2. Place the middle ceramic matrix into the fire so that the flat surface sits on the burner tray. Push the middle ceramic back until it rests against the rear ceramic shown in diagram A9.

Note!

Make sure that the middle ceramic does not block any of the burner tray slots.



Diagram A9



Diagram A10

3. Place the front ceramic matrix into the fire so that it sits between the middle ceramic matrix and the 2 front tray supports (Steel brackets at the front of the tray) shown in diagram A10.

Fitting the Loose Ceramic Coals

4. The first row of coals consists of 4 small coals and 4 large coals. The first row of coals are placed so that they sit on top of the front and middle ceramic matrices.

Starting with a large 'diamond shaped' coal, place the front of the coal on top of the left hand support leg of the front ceramic. The back of the coal should rest on the middle ceramic. Then take a small coal and place the front of it in the first left notch in the front ceramic, the back of the coal resting on the centre ceramic.

Continue this process, alternating the coal size until all the 8 coals are placed as shown in Diagram A11.



Diagram A11

Note!

Make sure that the coals do not fall down between the front and middle matrices. A gap must be left between the coals to allow the flames to pass through.



5. The second row of coals consists of 4 medium sized coals. They are placed between the large coals so that they sit on the middle ceramic, shown in Diagram A12.

Note!

The coals must not block the gap between the middle and rear ceramic matrices.

Diagram A12

6. The third row of coals consists of 6 medium sized coals (6 small coals for LPG stoves). The coals are placed so that they sit on top of the last row of coals and into the notches on the rear ceramic matrix, shown in Diagram A13.

Note!

Gaps must be left between the coals for the flames to pass through.



Diagram A13

7. The fire-bed should now be completed. The stove should be lit and the flame picture checked with the glass panel fixed securely in place. Any adjustments to the flame picture can then be made as required.

The stove can now be re-assembled as shown in ‘**Re-assembling the Stove**’ – Page 14

Section B - Fitting the Log Effect Ceramic Matrices

The fire-bed is constructed of 3 ceramic matrices and 6 loose logs.



Diagram B8

A. Place the rear ceramic matrix into the fire as shown in diagram B8. The ceramic should sit on the burner tray top and be placed so that it touches the back of the firebox. As shown in Diagram B8.

B. Place the middle ceramic matrix into the fire so that the flat surface sits on the burner tray. Push the middle ceramic back until it rests against the rear ceramic shown in diagram B9.



Diagram B9

Note!

Make sure that the middle ceramic does not block any of the burner tray slots.



Diagram B10

C. Place the front ceramic matrix into the fire so that it sits between the middle ceramic matrix and the 2 front tray supports (Steel brackets at the front of the tray) shown in diagram B10.

Fitting the Loose Ceramic Logs



Diagram B11

D. Starting with the Y-shaped log, place at the angle shown in diagram B11. The bottom of the log should sit in the cut-out on the front ceramic matrix, with the flat underside of it resting on the flat area on the middle matrix. Of the longer 2 branches, the tip of the right hand branch should rest in the left hand cut-out on the rear ceramic.



Diagram B12

E. The second log has two short branches coming from it. It sits in the furthest left cut-out on the front ceramic and rests in the groove on the centre ceramic, shown in diagram B12.

F. The third log to be placed is the thin 'twig'. The 'Twig' is placed in the cut-out between the first two logs. The small branch on the twig should sit at an angle into the cut-out on the front ceramic and so stopping the twig from falling between the front and centre ceramic. The top of the twig should rest on the large log as shown in diagram B13. (Make sure that the position of the 'Twig' does not block any of the burner ports)



Diagram B13



Diagram B14

G. The fourth log is the shorter of the two straight logs. The log should rest on the middle ceramic on the flat section to the right of the large log. The top of the log should rest in the groove on the rear ceramic, as shown in diagram B14.

H. The fifth log is the longer of the two straight logs, the top of this should sit in the final groove on the rear ceramic in between the large log and the shorter straight log. The log should also rest on the join between the other 2 placed logs as shown in diagram B15.



Diagram B15



Diagram B16

I. The sixth and final log has a single branch coming from it and one end is shaped to be parallel with the mirrored side. It should sit on the flat surface on the centre ceramic as shown in diagram B16.

J. The fire-bed should now be completed. The stove should be lit and the flame picture checked with the glass panel fixed securely in place. Any adjustments to the flame picture can then be made as required.

RE-ASSEMBLING THE STOVE

8. When the desired flame picture has been achieved, the stove body can be reassembled.

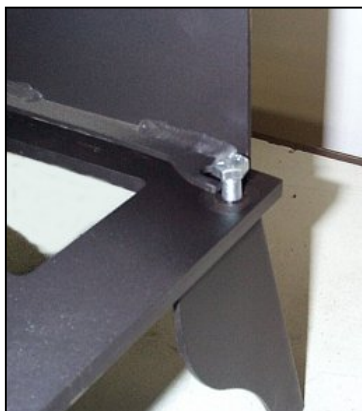

Diagram 14

The stove body can be slid back into place, making sure that the body locates onto the 2 securing bolts at the back of the base, shown in diagram 14 (There is no need to tighten these down).

The two front fixing bolts can then be replaced and tightened to fix the body in place (Shown in Diagram 4 – Page 6).

9. The cast iron doors can then be refitted which is the reverse process of that shown in Diagram 3 – Page 6.

FITTING THE CANOPY – (OPTIONAL)



There are two types of canopy available for your Hunter Herald 6 gas stove.

The options available are:

- Low Canopy
- High Canopy

Both canopies fit in exactly the same way.

Once the stove body has been secured, the canopy can be simply slid into place on the top plate of the stove body (Shown in diagram 15), making sure that the two welded tabs (located either side of the canopy) fit under the top plate.

Diagram 15



The canopy is then secured in place by tightening the fixing screws (one located either side of the canopy) with a flat-bladed screwdriver, shown in Diagram 16.

Diagram 16

TEST FOR SPILLAGE

A Spillage test **MUST** be made before the appliance is left with the customer.

Carry out the test by first closing all doors and windows in the room containing the fire.

Ensure that the fire is burning at full rate for a minimum of 5 minutes.

Using a smoke match – run along the edge of the draught diverter, as shown in diagram 17.



Diagram 17

If most of the smoke is not drawn into the draught diverter leave for a further 10 minutes and repeat test.

If there is a fan in an adjoining room the spillage test must be repeated with the fan running and all connecting doors between the fire and fan open.

If there are still problems the chimney/flue may require attention.

SPILLAGE MONITORING SYSTEM

This appliance is fitted with an ‘oxygen depletion system’ (ODS) pilot assembly which will monitor any spillage from the appliance.

The system **MUST NOT** be adjusted or changed by the installer.

Replacement systems must be obtained from Hunter Stoves; no other pilot assembly must be substituted in its place.

OPERATING THE APPLIANCE

FULL OPERATING INSTRUCTIONS ARE GIVEN IN THE USER INSTRUCTIONS.

Fitting the Remote Control (Optional)



Diagram 18

Fitting the Motor to the Valve

Un-screw the cover retaining screw with a small Philips screwdriver, shown in Diagram 18. Prise off the cover at the snap connection that is located on the right-hand side of the valve with a small flat-bladed screwdriver.

Turn the main burner control knob (Knob 'B' – diagram 19) fully anti-clockwise until the end stop is reached.

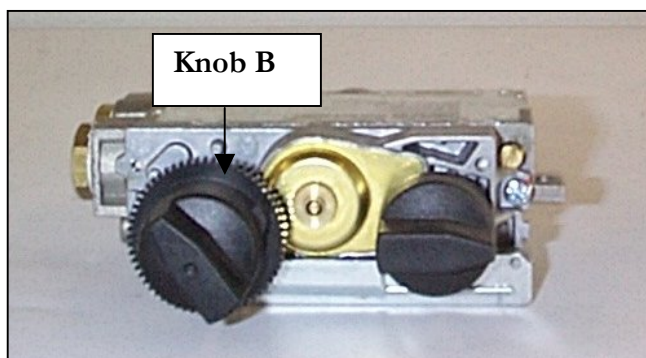

Diagram 19

Motor

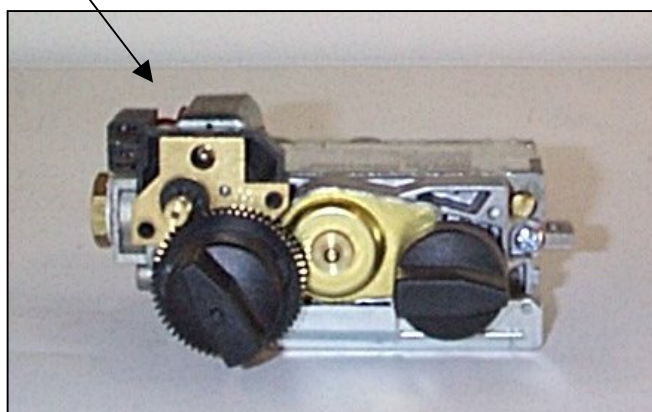

Diagram 20

Fit the motor as shown in diagram 20, making sure that the motor sits on the locating pin.

Replace the valve cover and tighten the Philips headed screw. (Do not over-tighten the screw as this may effect the operation of the control). Make sure that the snap connector has located properly. When fitted correctly, the valve cover holds the motor in the correct position.

Attaching the Remote Control Receiver Box

The control lead is then attached to the receiver box using the plastic connector and to the valve motor by the two spade terminals.

The Remote Control Receiver Box is powered by 4 x AA batteries (supplied). The batteries are fitted by sliding the cover off the receiver box the orientation of the batteries shown on the diagram in the box.

Fit the 9-volt battery to the remote control handset.

Test that the remote control system is working by pressing the increase and decrease buttons on the handset.

If the system is working correctly, the receiver box can be sited. The ideal position for the receiver box being on the hearth, at the back of the stove. The remote control system is ultra-sonic and hence the receiver box does not have to be in line of sight of the remote handset.

WARNING!

The receiver box should not be sited anywhere that the temperature will be greater than 50° Celsius. High temperatures will shorten the battery life and may cause the remote control receiver to stop operating.

SERVICING INSTRUCTIONS

It must be understood that any recommendations made here are in addition to the standard servicing procedures used by the servicing engineer.

1. A CORGI registered fitter using only original Hunter Stoves parts should carry out servicing.
2. Remove the stove body and glass as described on Page 6 (Removing the Stove Body).
3. Carefully lift-off the 'coals/logs' and remove the 3 ceramic matrices.
4. Using a soft brush, clean away any lint or light carbon soot deposits out of the gas ports on the burner top plate.
5. Replace the ceramic matrices and loose 'coals/logs' as per the coal arrangement instructions (Page 9- Fire-bed Arrangement) using all re-serviceable 'coals/logs' and any new replacements. Replace the glass, stove body and the doors.
6. Check the gas operating pressure and pipe work for soundness, carry out a spillage test and check the condition of the flue system.

SPARES LIST

PART DESCRIPTION	PART NUMBER
Bundy Tube – Main Burner	HG06/032
Bundy Tube – Pilot	HG06/033
Bundy Tube -- Inlet	HG06/034
LPG Burner Injector	HG06083
Nat. Gas Burner Injector	HG01BU024
Flue Collar	HG06/038
Flue Blanking Plate	HG06/037
Flue Gasket	HG01CE001
Glass Panel	HG06/036
Glass Sealing Kit (Adhesive Tape)	HG06/101
Glass Clip + Screw	HHR08/046
Door Knob (Cast)	HFR07/028
Door Knob (Brass)	HFR07/028B
Slider Knob (Cast)	HHR08/045
Slider Knob (Brass)	HHR08/045B
Natural Gas Pilot Assembly	HG06/090
LPG Pilot Assembly	HG06/085
‘Coal Effect’ Ceramic Spares	
Small Ceramic Coal	HG06/044
Medium Ceramic Coal	HG06/045
Large Ceramic Coal	HG06/046
Front ‘Coal Effect’ Ceramic Matrix	HG06/041
Middle ‘Coal Effect’ Ceramic Matrix	HG06/042
Rear ‘Coal Effect’ Ceramic Matrix	HG06/043
‘Log Effect’ Ceramic Spares	
Front ‘Log Effect’ Ceramic Matrix	HG06/071
Middle ‘Log Effect’ Ceramic Matrix	HG06/072
Rear ‘Log Effect’ Ceramic Matrix	HG06/073
Log 1 – ‘Y – Shaped’	HG06/074
Log 2 – Small branch log	HG06/075
Log 3 – 203 x 38mm Single branch	HG06/076
Log 4 – 152mm Double branch	HG06/077
Log 5 – 152 x 38mm Single branch	HG06/078
Log 6 – ‘Twig’	HG06/079



Unit 6, Old Mill Industrial Estate, Stoke Canon, Exeter, Devon, United Kingdom
www.hunterstoves.co.uk