

Dovre 550 Cast Iron Cleanburn Wood Stove

INSTALLATION INSTRUCTIONS



Dovre 550 Cast Iron Cleanburn Wood Stove Installation and Operating Manual

These instructions should be read carefully and saved by the user for future reference

CONTENTS

INTRODUCTION TO YOUR DOVRE STOVE	Page 2
UNPACKING	Page 3
GETTING THE BEST FROM YOUR STOVE	Page 3
LOCATION FOR THE INSTALLATION	Page 3
ASSEMBLY	Page 4
INSTALLATION	Page 5
CHIMNEY CONNECTIONS	Page 5-6
THE CHIMNEY	Page 6-7
OPERATING YOUR DOVRE STOVE	Page 7
SERVICING & MAINTENANCE	Page 6-7
GUIDE TO BURNING WOOD	Page 7
TROUBLE-SHOOTING	Page 7
WARRANTY DETAILS	Page 7

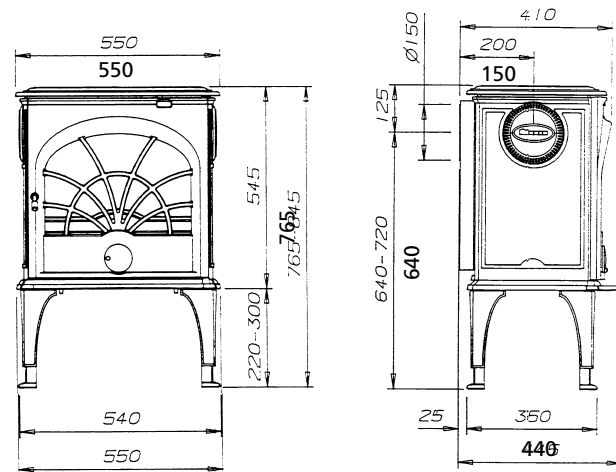

FIG.1. STOVE DIMENSIONS

INTRODUCTION TO YOUR NEW DOVRE 550CB

We would like to thank you for purchasing a Dovre stove and we trust that it will provide you with many years of useful service.

At Dovre we have been producing cast iron stoves for over 60 years and we strive to ensure that our products meet with the highest level of performance, efficiency, safety and quality. So much so that we guarantee all Dovre body castings for 10 years.

Owning a stove might be a new experience for you. Therefore, to ensure that you get the best performance from your new Dovre, do please take a little time to read through this manual.

The 550 CB is a specially designed stove for burning wood with clean emissions. It is essential that when wood is used, it is well seasoned for a minimum of 2 years and has maximum moisture content of 20%. If unseasoned wood is used, heat outputs will not be obtained and serious damage will occur in the chimney and flueways.

The dimensions of your new stove are illustrated in fig. 1. Be careful to ensure that your fireplace is going to accept the appliance and that you have allowed for at least 225mm of hearth space in front of the stove.

WE DO RECOMMEND THAT WHEREVER POSSIBLE, YOUR DOVRE IS FITTED BY AN EXPERIENCED INSTALLER ACCUSTOMED TO THE INSTALLATION OF CLASS 1 SOLID FUEL BURNING APPLIANCES.

If you are unsure about any aspect of the installation or operation procedures, your Dovre dealer will be pleased to help.

It is important that the Installation is carried out in compliance with current Building Regulations.

UNPACKING YOUR DOVRE 550CB

Your Dovre 550 CB is constructed from high-grade quality cast iron and is therefore not light in weight. We recommend that two people are available to handle the unit.

Before taking your Dovre to its installation location, remove the outer packing. Open the appliance door.

Remove the following components:

- Ashpan
- Fixings pack
- Cast iron grate centre
- Ash rake

Check that the following parts are in the Fixings Pack.

- 1 Tub 400 gm Fire Cement
- Cast Iron Flue Spigot (part number 003410)
- 2 Decorative Blanking Plates part number 153280)
- 1 Plain Blanking Plate (part number 153320)
- 3 Blanking Plate retaining bars (part number 072160)
- 4 Legs (part number 522190)
- 4 Leg extensions (part number 522200)
- L shaped handle support bracket
- Operating Tool (part number SLT5/01)
- Pack containing over plate remover and instruction sheet. (Part number 72301.0)
- Miscellaneous fixing pack including fixing screws and door handle
- Quality control ticket (IMPORTANT TO RETAIN TICKET IN CASE OF FUTURE CLAIMS)

Assemble the handle referring to fig.2 below

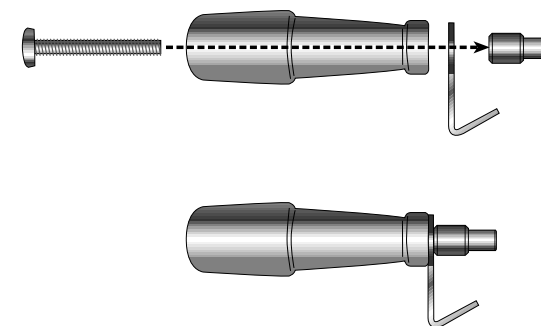

FIG.2 HANDLE ASSEMBLY

GETTING THE BEST FROM YOUR DOVRE 250

There are 4 golden rules to follow:

- 1 USE GOOD FUEL - NEVER BURN UNSEASONED OR DAMP WOOD
- 2 YOU MUST HAVE A GOOD CHIMNEY DRAUGHT - NEVER USE YOUR DOVRE STOVE WITH A POOR CHIMNEY
- 3 AVOID OPERATING THE STOVE FOR LONG PERIODS ON CONTINUOUS LOW TEMPERATURE
- 4 NEVER USE SOLID FUEL ON YOUR DOVRE 550CB

LOCATION FOR THE INSTALLATION

The location in which your stove is to be installed will of course depend on the chimney available. If you do not have a chimney, there are a number of prefabricated flue systems available and your Dovre Dealer will be pleased to offer guidance on the subject.

Building Regulations must be observed when considering the location of your Dovre. More precise information can be found later in this manual but it is important to ensure that a suitable hearth, complying with Building Regulations, is available.

NEVER ALLOW A MECHANICAL AIR EXTRACTOR TO BE USED IN THE ROOM OR ADJOINING ROOMS AS THIS COULD CAUSE THE APPLIANCE TO EMIT SMOKE INTO THE ROOM.

IMPORTANT - FLUE CLEANING

It is essential that an access point for cleaning the chimney be incorporated in the installation. This can normally be carried out by fitting an external soot door or access plate in the flue pipe. Access for rear flue connections can be made using a tee section soot trap at the base of the flue pipe. See fig.3 below.

Your 550CB is equipped with a special top baffle plate designed to direct pre-heated secondary combustion air. It is essential that access be allowed for cleaning the topside of the baffle.

REAR FLUE CONNECTION

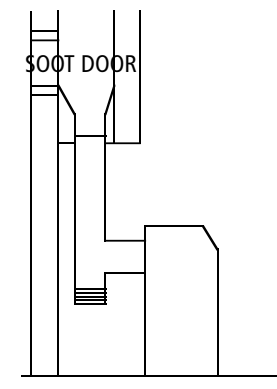

TOP FLUE CONNECTION

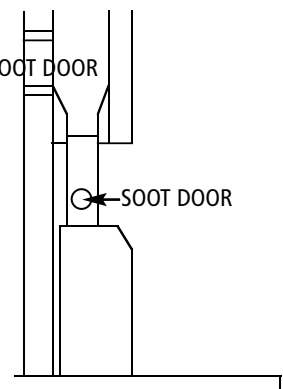

FIG.3 SOOT DOOR LOCATION

ASSEMBLY

REMOVE AND KEEP ON ONE SIDE, THE REAR SHEET METAL HEAT SHIELD PLATE USING a 10mm SPANNER.

Carefully lie the stove on its back. It will be helpful to lay the stove on two wooden battens.

Remove the wooden pallet.

FIXING THE STOVE LEGS

Remove the 4 nuts and washers, using a 13mm spanner, on each of the 4 supporting threaded lugs located on each corner of the base of the stove.

Attach the 4 legs. Refit the 4 nuts and washers and tighten securely.

Fit the inner leg extension sections using the large black washers and hexagon headed 25mm x 8mm bolts. Using a 10mm spanner, tighten the bolts and adjust for height as necessary.

Fit the L shaped handle support handle adjacent to the front left leg using a 17mm x 8mm bolt and washer.

Carefully stand the stove in the upright position.

FITTING THE FLUE CONNECTOR

If your Dovre is to be connected to the chimney via the rear flue connector, proceed as follows.

Remove the fixed circular flue cover plate on the rear of the stove using the kit supplied (part no 72301.0)

Apply a thin and even coat of fire cement to the flange on the flue spigot. Fix the flue spigot in position using the 2 threaded hook bolts, nuts and washers and tighten using a 13mm spanner.

If your Dovre is to be connected to the chimney via the top flue connector, proceed as follows.

Remove the fixed circular flue cover plate on the top of the stove using the kit supplied (part no 72301.0)

Apply a thin and even coat of fire cement to the flange on the flue spigot. Fix the flue spigot in position using the 2 threaded hook bolts, nuts and washers and tighten using a 13mm spanner.

FIXING THE SIDE COVER PLATES

Apply a thin coat of fire cement to one of the two side cover plates (part no 153280) and place in position over one of the holes in the side of the stove. Place a fixing bar (part 072160) using a bolt and washer on the rear side of the circular plate (inside the stove). Ensure that the flat side of the bar is towards the side of the stove. Tighten securely using a 10mm spanner. Repeat process for the opposite side of the stove.

REFIT THE REAR HEAT SHIELD (IF REAR FLUE CONNECTION IS USED IT WILL BE NECESSARY TO KNOCK OUT THE CUT OUT FLUE SECTION ON THE HEAT SHIELD.

NOTE: THE SPARE BLANKING PLATE (PART NO 153320) SHOULD BE KEPT FOR FUTURE USE IN CASE THE FLUE ARRANGEMENT IS CHANGED

Fit the grate centre grill (part no 56214.0) in the space on the hearth plate inside the stove.

Place the ash pan in position.

INSTALLATION

HEARTH & CLEARANCE REQUIREMENTS

INSTALLATION AGAINST A WALL

For installation as a free standing unit e.g. against a wall. (See fig.4)

The minimum hearth required is 840mm (33") x 840mm (33") and the unit must not be placed less than 150mm (6") from the back and sides of the hearth. The wall must be constructed from non-combustible materials and must be a minimum height of 1200mm (48"). The required wall thickness will depend on the distance between the back of the stove and the wall. If this distance is less than 50mm (2"), the wall should be at least 200mm (8") thick. If the distance from the back of the stove to the wall is between 50mm (2") and 150mm (6"), the wall thickness must be at least 75mm (3") thick. If single wall flue pipe is attached to the appliance, the pipe should be a minimum of three times its diameter from any combustible materials.

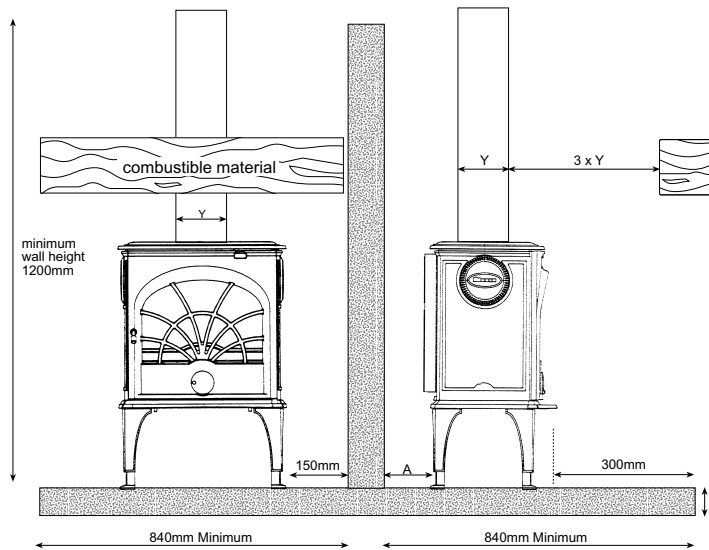

FIG.4

INSTALLATION IN A FIREPLACE RECESS

For installation in an fireplace recess or inglenook the hearth must extend 500mm (20") in front of the recess and extend either side of the recess by 150mm (6")

The distance the hearth must protrude in front of the appliance should be a minimum of 300mm (9")

The minimum thickness of hearth should be 125mm (5") and this may include the thickness of a concrete floor including hearth tiles. If a hearth is constructed and / or supported on timber, the timber should be at least 550 mm (10") away from the top surface of the hearth.

If a timber mantel is installed, the distance from the stove body and / or any single skin flue pipe, if attached to the top of the stove, to the mantel must be a minimum of 450mm (18").

CHIMNEY CONNECTIONS

CONNECTION FROM THE TOP OF THE APPLIANCE (See fig.5)

A non-combustible register plate should be fitted to the lower section of the chimney.

150 mm diameter 316-grade 1mm thick stainless steel flue pipe or vitreous enamel pipe suitable for use with solid fuel appliances should be used to connect the top spigot of the stove to the chimney or chimney liner. All connecting joints must be female pointing up and joints should be properly sealed with fire cement. If the chimney is not immediately above the stove, off set bends of either 30 degree or 15 degree angles may be used. Try to avoid long runs of pipe that are not vertical.

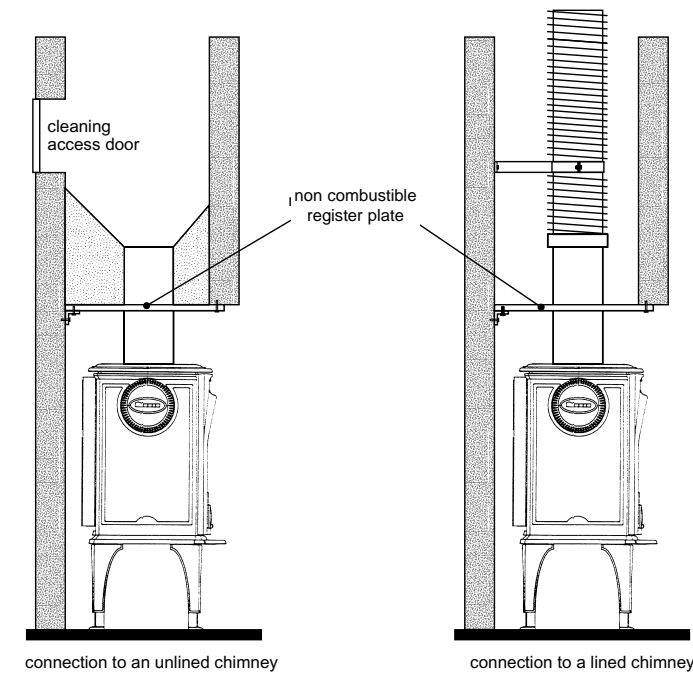

FIG.5

CONNECTION FROM THE REAR OF THE APPLIANCE (See fig.6)

A non-combustible register plate should be fitted to the lower section of the chimney.

150 mm diameter 316-grade 1mm thick stainless steel flue pipe or vitreous enamel pipe suitable for use with solid fuel appliances should be used to connect the rear spigot of the stove to the chimney or chimney liner. All connecting joints must be female pointing up and joints should be properly sealed with fire cement. If the chimney is not immediately above the stove, off set bends of either 30 degree or 15 degree angles may be used (see fig.7). Try to avoid long runs of pipe that are not vertical. Start by connecting a 90-degree or 45 degree "T" section to the flue spigot at the rear of the stove.

NEVER INSTALL HORIZONTAL PIPE RUNS OVER 150mm (6") DIRECTLY OFF THE BACK OF THE STOVE

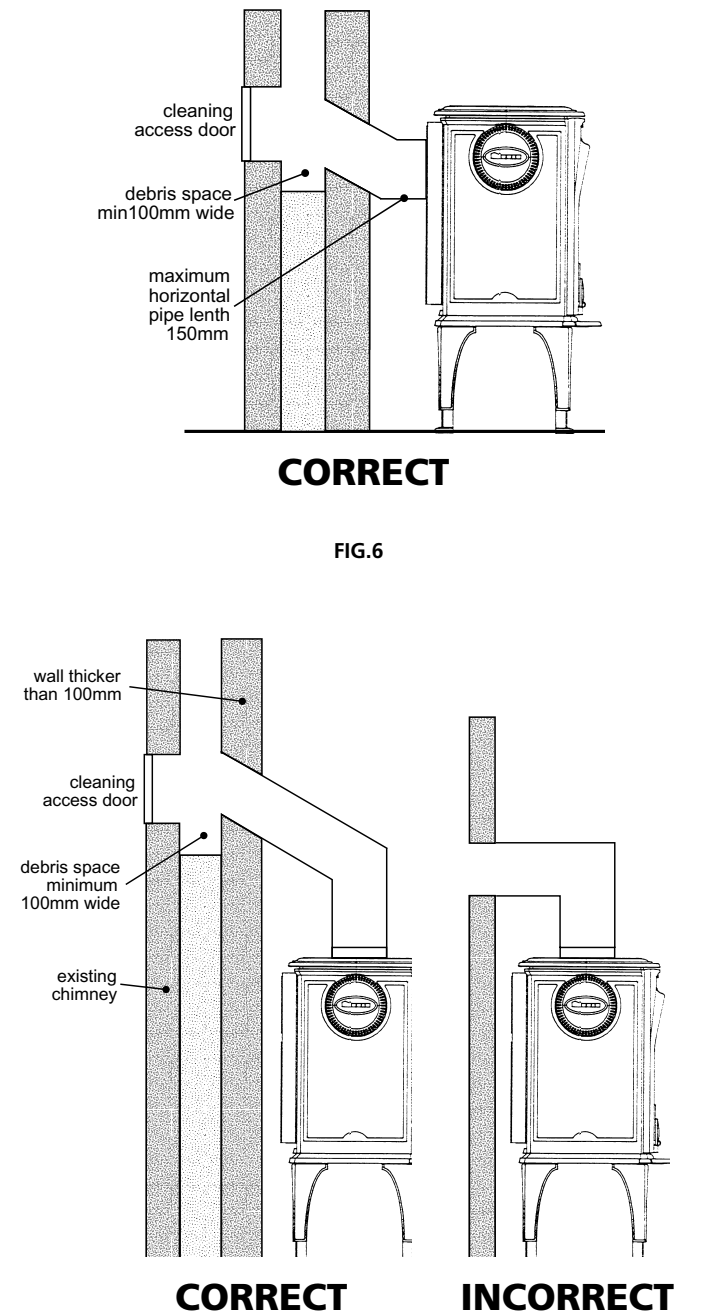

FIG.6

FIG.7

THE CHIMNEY

ACCESS FOR SWEEPING CHIMNEY

The chimney should be checked and swept at least once a year and it is important to allow provision for gaining access to the chimney. On masonry chimneys, a standard soot door, obtainable from your Dovre dealer, can be used. On other factory made chimneys, it is important to ensure an access-cleaning door is provided. It is advisable to ensure that the connecting flue pipe to the chimney has an access door fitted. An access door close to the appliance will also facilitate the use of a chimney vacuum cleaner to ensure clean appliance maintenance.

AIR SUPPLY

Your Dovre 550 CB requires an air supply to the room. The air vent should have a minimum air flow area of 220 sq. cms (4" sq.)

THE CHIMNEY

(Minimum height requirement 4.5 metres (16 ft.)

CHIMNEY DRAUGHT

DRAUGHT REQUIREMENT: 1.5 to 2mm

Too much draught will cause excessive heat outputs and fuel consumption. Inadequate draught may cause smoke emission to the room and poor combustion resulting in a build up of tar and creosote deposits on the glass, inside walls of the appliance and the chimney.

FOR EXISTING CHIMNEYS, always ensure that the chimney is checked and swept prior to the installation taking place.

This is one of the most important aspects of the installation of your Dovre stove. It is important to ensure the following.



MASONRY CHIMNEYS

The chimney must be sound, in good condition and must not be shared with another appliance. In the event of the chimney being unlined, it is advisable to have a survey carried out to check for the presence of leakage and other defects. Lining the chimney with a suitable 150mm (6") diameter liner for wood burning and solid fuel burning applications, will improve the performance and efficiency of the stove.

THE ADVANTAGES OF A LINED CHIMNEY

With most unlined chimneys, the cross section of the chimney is excessive as in the case of large old inglenook fireplaces. Because of the large volume of cold air in large chimneys, it is difficult for the flue gases to rise easily through the chimney. This causes the unburned volatiles in the smoke to adhere to the chimney walls.

The inner surfaces of some unlined chimneys are rough with jagged edges causing difficulties in obtaining a good draught.

Unlined chimneys are often defective with cracks leaking fumes into other parts of the house.

Larger, unlined chimneys, being cold, encourage the formation of tars (wood smoke condensation), which can penetrate the walls of the chimney leaving unpleasant black stains on internal plastered walls.

PREFABRICATED CHIMNEY SYSTEMS

If a masonry chimney is not available, there are a number of proprietary brand prefabricated flue systems available. Your Dovre Dealer will be pleased to offer information and advise on this subject.

CHIMNEY TERMINAL

Down draught problems may be experienced if the top of the chimney is close to adjacent taller trees and / or buildings. Your Dovre Dealer will be pleased to advise on suitable anti downdraught cowls should these conditions prevail.

OPERATING YOUR DOVRE 550CB

Provided that your Dovre stove has been installed in accordance with the above installation procedures, you should now be ready to "light up"

Your Dovre has been treated with a high temperature resistant protective paint, which produces an odour when the stove is new. We recommend that you leave a window open during the first few hours of use while the paint is curing.

CONTROLLING YOUR DOVRE 550 CB

There are two fundamental air controls on your Dovre 550 CB, the lower spin wheel air control and the top lever air control. Use the handle tool to adjust settings.

The top air control should be generally left in the fully open position. If the top air control is left for long periods in the closed position, the air wash system will not function and the glass will quickly discolour. The lower air control should only be opened when first lighting or re-fuelling with wood.

Choose well seasoned hardwood logs 40cms (16") in length and no greater than 75mm -150mm (3 to 6") in diameter.

REMEMBER: THE DRYER THE WOOD THE BETTER

WET UNSEASONED WOOD PRODUCES CREOSOTE AND TAR IN THE CHIMNEY AND CAUSES RAPID BLACKENING OF THE GLASS DOOR.

To light your DOVRE 550 CB:

- Open the lower air control wheel.
- Open the top air vent fully by sliding the lever to the left.
- Ensure that the ash grate grill is in the closed position by sliding to the right.
- Lay rolled up newspapers and small sections of wood (kindling wood) on the base of the stove. Light the paper with a long taper. If kindling wood is not available, firefighters may be used with small pieces of split wood laid on top of the firefighters.
- Close the door but do not fully lock at this stage. The fire should now start to burn fiercely and brightly. If this does not happen, check for chimney blockage.
- As soon as the wood is burning with a well-established heat, add 2 or 3 logs and close the door tightly.
- After a further couple of minutes fully close the lower air control.

REMEMBER

OPERATE YOUR DOVRE WITH THE BOTTOM AIR CONTROL CLOSED

CONTROL THE BURNING RATE BY ADJUSTING THE TOP AIR CONTROL

OVERNIGHT BURNING

Before retiring to bed:

- Ensure that there is a good hot base to your fire and fully load the fire with hardwood logs (ideally 40cms (16") long with a maximum diameter of 150cms. (6")
- Open the lower and upper air controls to allow the fire the fire to burn fiercely. After 2 or 3 minutes, close the lower air control fully and close the upper air control to the "almost" fully closed position.
- If you require your stove to be used the following morning, carry out the following procedure:
- Wipe the door glass clean using a damp cloth and polish off with a paper towel or clean cloth.
- Open the lower and upper air controls.
- Using the ash rake, lightly rake the ashes in the stove, bringing any hot embers to the centre of the grate.
- Place small sections of wood on the grate and close the stove door to the "almost" closed position.
- When the fire becomes established, add more fully and proceed as above (see section 'To light Your Dovre 550CB' above)

CARE & MAINTENANCE OF YOUR

DOVRE STOVE

CAUTION

IF THE APPLIANCE EMITS SMOKE INTO YOUR ROOM, IT IS NOT THE FAULT OF THE APPLIANCE. THERE WILL EITHER BE A STRUCTURAL FAULT OR DESIGN FAULT IN THE CHIMNEY OR LACK OF VENTILATION IN THE ROOM.

REMOVING ASHES

Slide the centre grate grill to the open position. Using the rake tool, slide some of the ashes to the centre grate allowing the ashes to drop into the ash pan. It is not necessary to clear all the ash from the grate area. A bed of ash up to 12mm deep can be left on the grate area.



MANAGING YOUR WOOD SUPPLIES

If you are buying wood from a log merchant, try to ensure that the wood has been seasoned for at least 2 years. 3 years is even better. The wood should preferably be cut to lengths of 40cms (16") and split to a width of between 5 and 15cms (2-6").

Store your wood under cover to protect from rain but ideally the wood should be stored in a place where the wind will be allowed to freely ventilate the stack.

Try to obtain hardwoods such as oak, elm, beech or ash. These woods will provide more calorific value per cubic meter than softwoods.

TROUBLESHOOTING

SMOKE EMISSION

If smoking occurs when the stove door is opened, it is a sign that the flue draught is inadequate. Mostly, burning unseasoned wood causes this condition and it usually indicates that the combustion temperature is too low. To overcome a weak draught, ensure your wood is dry and build a hot fire, leaving both air controls in the fully open position. If the problem persists, arrange for your chimney to be expertly checked for design and construction faults. In some instances, down draught conditions will exist and it may be necessary to fit an anti down draught device to the top of the chimney.

FIRE DOES NOT BURN FOR LONG PERIODS

Wood can contain a number of variable factors related to species, weight, age and moisture content. It is therefore difficult to be precise with regards to the length of burn time.

If it is thought that the fuel is burning too quickly: -

- The diameter of the logs is too small
- If softwoods are used, change to using hardwoods
- Excessive chimney draught. If so, fit a draught stabiliser
- Worn out door and glass seals need replacing.

Always try to avoid running your stove for long periods of time with the air controls closed. This point is particularly important if the wood is not well seasoned. Failure to do so will cause the glass, stove walls and chimney to become soiled with tar deposits.

TEN YEAR WARRANTY

If the castings on this appliance should prove to be defective within ten years of the purchase date, the faulty castings will be replaced free of charge, subject to the following conditions.

- 1** The purchaser shall complete the registration section herewith and return it within seven days of purchase. Failure to return the registration could result in delays in processing any claims.
- 2** The appliance shall have been installed in compliance with the installation instructions.
- 3** The appliance shall not have been used for the burning of unseasoned wood and/or prohibited fuels.
- 4** This warranty only applies to the appliance body castings and does not include renewable components including grates, ashpans, and glass, seals and baffle plates.
- 5** This warranty does not cover site visits and any claims should be notified to your dealer.

This warranty does not affect the Statutory Rights of Consumer Purchasers

Please complete and return this card within seven days of purchase to:

Dovre Castings Ltd., Weston Works, Weston Lane, Tyseley, Birmingham B11 3RP

Name:

Address:

.....

.....

.....

Telephone Number:

Model:

Date of Purchase:

Dealer:



Unit 1, Weston Works, Weston Lane, Tyseley, Birmingham B11 3RP.

Tel: 0121 706 7600. Fax: 0121 706 9182.

E-mail: enquiries@dovre.co.uk

Web site: www.dovre.co.uk