

Yeoman

The County Integral



Freestanding Stove

INSTALLATION, SERVICING AND USER INSTRUCTIONS

This product is for use only in Great Britain and Ireland (GB, IE)

These instructions are to be left with the customer, should be read carefully and kept in a safe place.

They will be necessary when servicing the appliance.

IMPORTANT

**THIS APPLIANCE MUST ONLY BE OPENED, INSTALLED AND SERVICED BY A
HETAS APPROVED INSTALLER**

PM170 Issue 1 (March 2006)

Contents

Welcome to Yeoman	3
Tehnical Specification	5
Installation	6
Positioning the Stove	6
Chimneys and Flues	6
How the Chimney works	6
What is Draught?	6
Tar Deposits and their removal	7
Chimney Options	7
Chimney Connections	7
Chimney Draughts - Ventilation	8
Checking the Draught	8
Assembling Your Yeoman Stove	8
Adjustable Door Cam	8
Final Checks	9
Initial Running in of the Stove	9
Lighting your Yeoman Stove	9
Controlling the Burning	9
Location and Operation of the Air Controls	9
Burning Wood	10
The Effect of Seasoning Wood	10
Burning your Yeoman Stove	10
Fuel Types	11
Installation	11
Operation	11
Overnight Burning	11
Care and Maintenance	11
Optional Extras	11
Water Heating	12
General Notes	12
Fitting Electrical Controls	12
Electrical Supply	13



Welcome to Yeoman

We are pleased that you have chosen one of our freestanding wood/multifuel stoves which have been designed for modern living. Owning such a stove shows an appreciation for exceptional quality.

Please read your manual thoroughly, its purpose is to familiarise you with your stove, and gives guidelines for its installation, operation and maintenance. If after reading this manual you need further information, please do not hesitate to contact your supplier.

IMPORTANT NOTICE

If your stove is installed correctly, it will give you many years of excellent service for which it was designed. Please read these instructions carefully and ask a HETAS Installer to install your stove for you.

WARNING

All types of heating appliance can be potentially dangerous. Correct installation and operating procedures must be observed when fitting this stove. Some parts of your stove are protected on their surface with heat proof paint. When the stove is first used it is normal for it to emit some light smoke, with an unpleasant smell. Though unpleasant, this is non toxic and is produced only whilst the stove paint fully cures. We recommend that you ventilate the room adequately until this disappears.

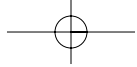

FOR YOUR RECORDS

To assist us in any Guarantee claim please complete the following information:-

YEOMAN DEALER APPLIANCE WAS PURCHASED FROM

Name:

Address:

.....

Telephone number:

ESSENTIAL INFORMATION - MUST BE COMPLETED

Date installed:

Model Description:

Serial number:

INSTALLATION ENGINEER

Company name:

Address:

.....

Telephone number:

COMMISSIONING CHECKS (TO BE COMPLETED AND SIGNED)

Is flue system correct for the appliance YES NO

Flue swept and soundness test complete YES NO

Smoke test completed on installed appliance YES NO

Spillage test completed YES NO

Use of appliance and operation of controls explained YES NO

Instruction books handed to customer YES NO

Signature: Print name:

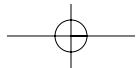

TECHNICAL SPECIFICATION

1. Component List

For County Integral Stove

- | | |
|---|----------------------------|
| 1 No. | Body complete with door/s. |
| 1 No. | Log retaining bar. |
| 1 No. | Instruction manual. |
| 1 No. Cardboard box containing:- | |
| 1 x | Cast Flue spigot. |
| 1 x | Cast Flue blanking plate. |
| 2 x | Baffle extension tubes, |
| 2 x | M8 Roofing Bolts, |
| 2 x | M8 Flat washers, |
| 2 x | M8 Square nuts, |
| 2 x | Allen headed bolts, |
| 2 x | Pozi headed bolts |
| 1 x | Allen key, |
| 1 x | Cast Door tool. |
| | |
| 1 No. | Multi-Fuel kit |
| 2 No. | Side plates |
| 1 No. | Ashpan. |
| 1 No. | Ashpan tool. |
| 1 No. | Cast grate. |
| 1 No. | Deepening bar. |

2. Dimensions of stove

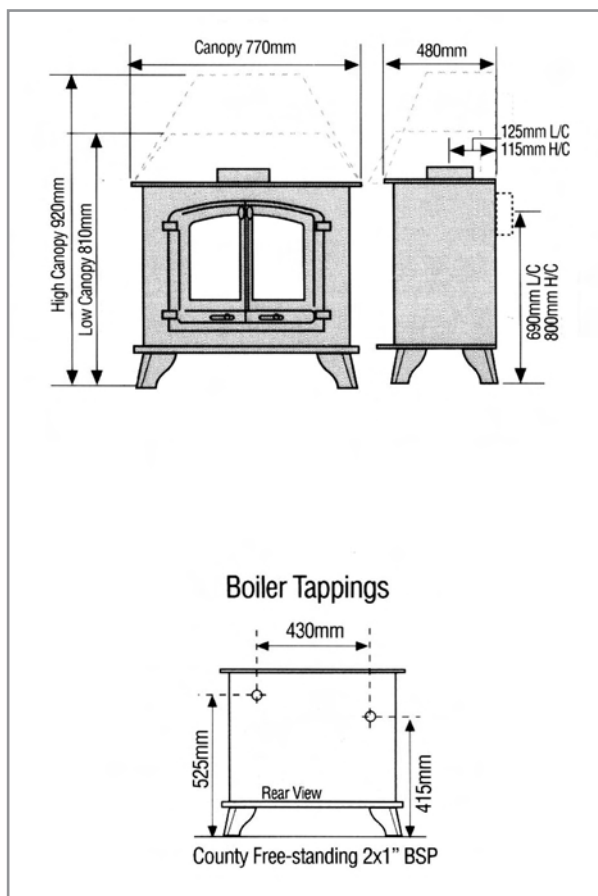

INSTALLATION & USER INSTRUCTIONS

1. Installation

The way in which the stove is installed will influence its safe, effective and efficient running.

It is of the utmost importance to ensure that the installation is up to the correct standard.

Installation of your Yeoman Stove must comply with current building regulations. Yeoman Stoves therefore recommend that a HETAS professional fitter be employed for this task. The installer will provide you with information about the safety limits of the installation and should fix a notice plate in a place where it can be readily seen, eg: next to the electricity meter.

2. Positioning the stove for the best results

Your Yeoman Stove emits heat both by radiation and convection; heating walls, ceilings, furniture, etc. by warming air, which carries heat to the furthest parts of the room.

The Yeoman Stove produces a soft even heat that allows you to enjoy maximum comfort in your home.

All stoves should be installed in accordance with the building and HETAS regulations. A note of some of the points, but in no way a comprehensive list is given below;

Your Yeoman Stove must be placed on a noncombustible hearth, extending 300mm in front of the stove, and 150mm to either side of the stove.

When the stove is placed near a wall or partition, it must have a clearance of at least 300mm, unless the wall is made of a noncombustible material, which is at least 75mm thick, in which case the minimum clearance should be 50mm.

3. Chimneys and Flues

The successful operation and efficiency of your Yeoman Stove is dependent upon the following criteria: -

- a.) The operation of the chimney.
- b.) How you use your Yeoman Stove.
- c.) The quality of the fuel used.

The following information is designed to help you to decide whether you can use your existing chimney, whether a new one should be built or a chimney liner fitted.

4. How the Chimney Works

A basic understanding of how a chimney works will help you to obtain the greatest benefit that you can from your chimney. The chimney has two main functions, which are, to safely remove the smoke, gases and fumes from the house, and to provide a sufficient amount of draught in the stove to ensure that the fire is kept burning brightly.

5. What is Draught?

The basic principle that hot air will rise gives rise to draught in the chimney. When your Yeoman Stove is lit, hot air rises up through the chimney. This air is then exhausted at the chimney pot where it is diluted within the surrounding atmosphere. When the chimney temperature is maintained the draught will also be maintained. If the stove and chimney are not hot then the draught will not function to its best potential. The position, size and height of the chimney are all factors that effect the performance of the draught.

6. The Following Factors Must be Considered

- Chimneys situated within the house are insulated from the cold – thus the extra warmth gives a greater draught.
- The minimum size of a chimney is 150mm in order to maintain a good draught.
- The height of the chimney effects the draught. The minimum height is 4 metres. The higher the chimney the greater the draught.
- The chimney should be at least one metre higher than the highest point of the roof. incorrect

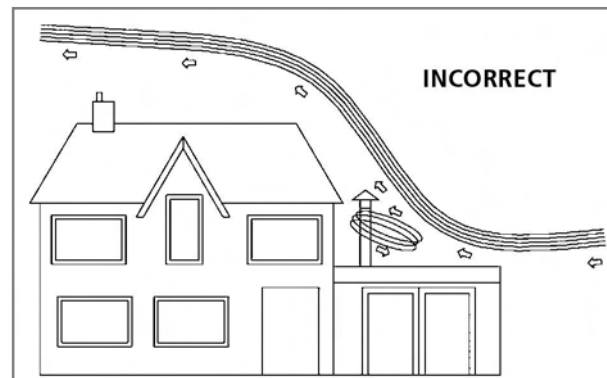

- Avoid the chimney opening out onto areas near buildings, where the air may be turbulent and inconsistent.
- If a chimney is opening out into an area near a building or obstruction, then its height should exceed the peak of the obstruction by at least 1 metre.

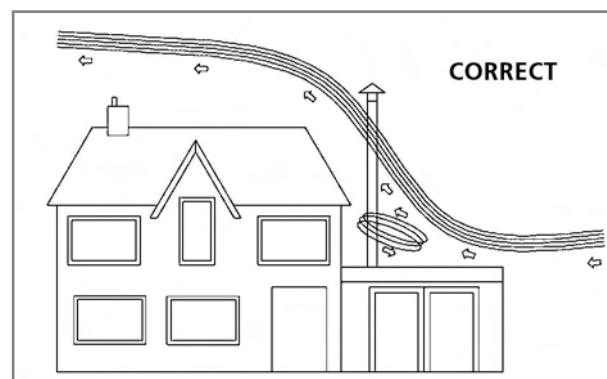

INSTALLATION & USER INSTRUCTIONS

- Internal walls of the chimney should be smooth and free from restrictive obstacles.
- Where pots meet with working chimneys, restrictions or reductions are to be avoided.

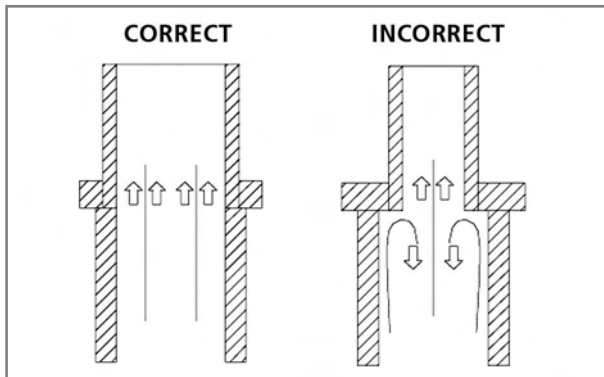

- If it is necessary to increase the draught then this can be achieved by extending the chimney.
- Any cowl that is fitted to the chimney must not impede the exhaust of the gases.

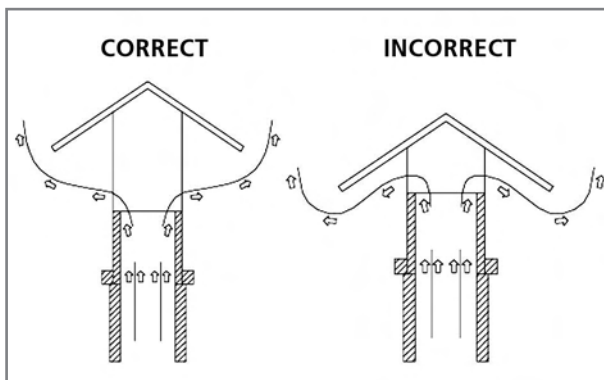

7. There are other factors which effect the draught.

- Residences that are highly insulated on the inside, without air vents, cause insufficient amounts of draught as air cannot enter the stove to form the draught. Improving room ventilation can rectify this problem.
- Trees and/or high buildings close to the property can cause turbulence.
- Wind speed. Generally, continuous strong winds increase the draught, but gusty winds decrease the draught.
- Outside temperature. The colder the external temperature the greater the draught.
- Baromic pressure. On rainy, stormy or humid days the draught is generally reduced.
- Strength of the fire. The hotter the fire the greater the draught.
- Cracks in the chimney. A badly sealed stove door and air holes in the flue joints are all factors which can reduce the quality of the draught achieved.

8. Tar deposits and their removal

When wood is burnt slowly tar and other organic gases are produced, which, when combined with atmospheric humidity, form tar. Any accumulation of tar should be cleared immediately. To help prevent the buildup of tar there are powders etc., available from your Yeoman dealer.

Since tar buildup depends upon so many contributory factors, it is difficult to accurately predict the correct interval at which the chimney should be cleared. Yeoman stoves therefore recommends visual inspection as the most prudent way of monitoring chimney condition.

For this reason it is recommended that the installation is easily accessible.

Further information and advice may be obtainable from a local chimney sweep.

9. Chimney options

If it is necessary to construct a chimney for your Yeoman stove there are three main alternatives.

- Brick chimney.
- Pumice chimney
- Metal chimney.

Studies show that there is no great difference between brick, pumice or metal chimneys concerning the draught that is generated.

However, you will get less of a tar build up using a pumice liner. Wherever possible you should position your chimney inside the house to obtain the best draught and reduce the accumulation of tar etc.

10. Chimney connections

A chimney should ideally be vertical, smooth and free of cracks and all foreign bodies. The chimney must be swept before lining or any connections. It is also essential that all flue pipes are well fitted and that their unions completely airtight.

Flues should be vertical wherever possible. Horizontal flue runs should be avoided except in the case of a back outlet appliance, when the length of horizontal section should not exceed 150mm.

Where a bend is necessary in a flue it should not make an angle of more than 30 degrees with the vertical.

Additionally any flue pipe passing through cavity walls should be sleeved or of twin wall construction.

When any flue pipes pass through a wall or closure plate there must be a reasonable area left behind the pipe in order to allow the gases to clear.

INSTALLATION & USER INSTRUCTIONS

Flue pipes should be sealed through an air tight 'register' or 'closure' plate and should be fitted above the point where the chimney narrows.

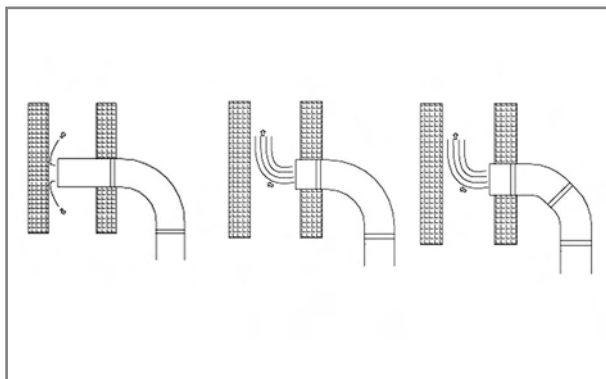

In order to maintain the temperature in a flue any external flueing must be of twin wall constructions.

Flue voids should be avoided, as these will also reduce the effectiveness of the draught.

Access should be provided for the inspection of the chimney and the clearing of any debris or accumulated soot and tar.

Flue pipe which is less in cross sectional area than that of the flue outlet of the stove, must not be used.

When the sections of the flue pipe fit into one another, the end facing upwards must be the end with the largest internal dimension. With the pipe orientated like this the downward facing end of the next pipe should fit inside it. In this way ledges inside the flue pipe do not collect ash or other deposits. Nor do these joints allow condensation to settle and weep through the connection.

11. Chimney Draughts - Ventilation

For your Yeoman Stove to operate correctly it is essential that the draught of the chimney, which determines the provision of air to the stove, is continuous. This is to ensure the evacuation of fumes during combustion. Therefore it is necessary to ensure that a constant supply of air is available via a permanent air vent. This permanent vent should have a minimum free area as shown in the chart below, depending upon the Yeoman Stove, which you have chosen to purchase.

Stove	Permanant Vent
COUNTY INTEGRAL	4400mm ²

12. Checking the Draught

Once installed, it is important that the flue draught is measured, using a 'flue draught gauge'. This gauge should be used to ensure that at the minimum firing rate, the draught should be approximately 0.5mm. This figure will vary linearly as the firing rate is increased until the maximum firing rate is achieved, at which point the gauge should show no more than 1.5mm.

If the draught at the maximum firing rate exceeds 1.5mm then additional stabilisers must be fitted.

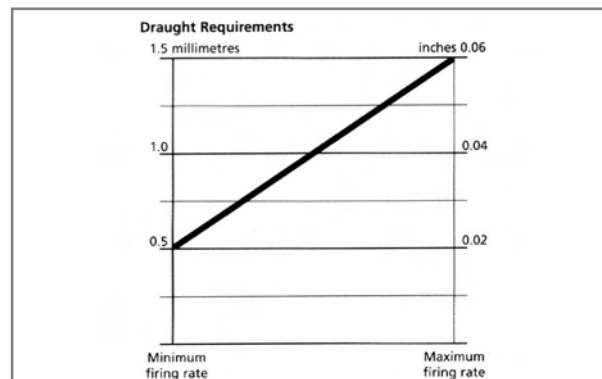

12. Assembling Your Yeoman Stove

All stoves are dispatched to the dealers with some loose fittings supplied in the base of the stove; - Flue Spigot, Flue Blanking Plate, Baffle Extension Tubes, Baffle and Multipurpose Tool along with any fixings that are required for the assembly.

The flue spigot can be used in either the top or the rear flue position. The flue spigot is fitted by securing it to the stove using the two spade headed bolts supplied. There are two holes in the flue spigot which are blanked off using the two 'bright' nuts and bolts supplied (unless a butterfly and spindle is fitted). The blanking plate must be fitted using the two allen headed screws, to cover the flue hole not being used. A thin smear of fire cement must be used on both pieces in order to achieve a good seal. The fire cement is best applied prior to tightening down the loose parts. All flue pipe must be fitted with the 'male' end pointing down.

13. Adjustable Door Cam

The door retaining device on your Yeoman Stove is a cam concentrically mounted on a threaded spindle. This means that a half turn of the knob results in initially latching and then pulling in of the door, compressing the rope and sealing the stove. The cam is adjustable to suit the 'bedding in' of your individual stove. To increase the pull of the cam, first open the door turn the cam anti-clockwise through one complete revolution, now close the door and operate as normal. In order to reduce the tension of the cam and decrease the effort when closing the stove the procedure is the same, however the rotation should be in a clockwise direction. **Yeoman stoves recommend that you grease the cam with copper ease after each season's use.**

INSTALLATION & USER INSTRUCTIONS

14. Final Checks

There are two other items that should be checked before first igniting the stove. These are firstly that the sides and rear of the stove are fitted with fire bricks, and secondly that the Ash Retainer and Log Bar are fitted. Both the Ash Retainer and the Log Bar are fitted behind the door of the stove in the two fabricated channels, the Log Bar being positioned so that the 'spikes' are pointing upwards and on top.

15. Initial Running in of the Stove

Yeoman Stoves recommends that when your Stove is first installed a couple of smaller fires be lit before stove will take these few lightings to fully cure the paint, so to gradually increase the temperature of the burn is of advantage to the longevity of the surface coating.

As the paint cures it gives off an unpleasant acrid odour, this is not harmful, but Yeoman Stoves does recommend closing internal doors and leaving windows open to keep the room well ventilated. Children and pets are best kept away during this process

DO NOT TOUCH OR WIPE THE STOVE DURING THIS PROCESS

16. Lighting your Yeoman Stove

Load the fire with the starting fuel, i.e. paper, dry sticks, or fire lighters and the timber to be burnt. Ensure that all air vents are left open, light the fire and close the doors so that they are just slightly ajar. Leaving the doors in this manner will prevent the ceramic door sealing rope from sticking to the paint during curing.

Wood burns most effectively on a bed of ash on the base of the stove. If possible before commencing initial burn place a bed of ash approximately 25mm deep on the base of the stove.

17. Controlling the Burning of Your Yeoman Stove

Your Yeoman Stove comes as standard with fully controllable **Primary air**, and **Secondary air**.

Primary air is the principal source of air when lighting the stove and burning the stove particularly hard.

Secondary air is the source of air, which is forced across the glass in order to reduce any products settling on the glass diminishing viewing pleasure. This air source is also referred to as the '**Air wash**'.

18. Location and Operation of Air Controls

Primary air – control is located on the doors of your stove. Either a standard operation rotary control (clockwise to close – anti-clockwise to open) on the single door appliance. Or alternatively two sliding plates (towards the centre of the stove to close – towards the outside of the stove to open) on the twin door versions of the appliance.

Secondary air 'Air wash' – control is positioned top right and left hand side of the stove in the shape of a circular control lever. "**Air Wash**" draws air in from the side of the stove which is pre-heated and is drawn down over the door glass to help keep the glass clear.

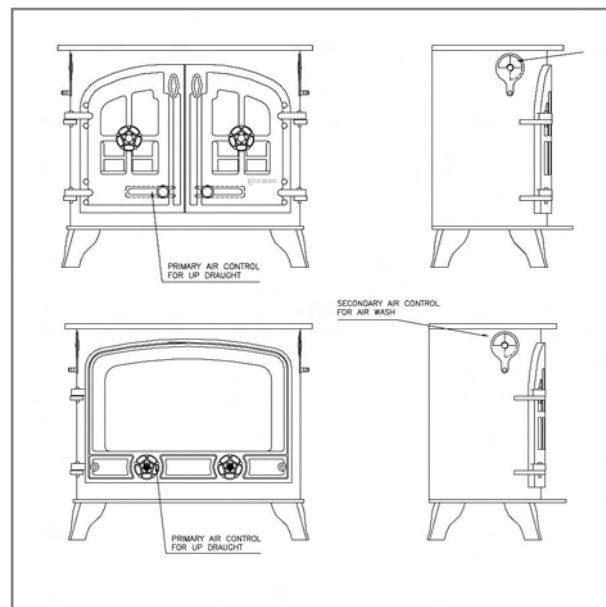

INSTALLATION & USER INSTRUCTIONS

19. Burning Wood

When burning wood Yeoman Stoves recommend that this is well seasoned. In order to achieve this it should be cut into logs and stored in dry conditions so that air can circulate through the pile for one to two years before burning.

As a guide to the dryness of wood, we would suggest that when looking at the end of a log, radial cracks deep enough to be described as splits, should be evident. If the wood is wet and unseasoned, then it will have considerable water content. Each litre of water the wood contains will reduce the heat output of the stove by one third of a kilowatt and will be boiled off in the form of steam. Burning wet wood not only reduces the heat output but also lowers the flue temperature, and can lead to the formation of tar deposits in the flue.

The following table shows the water content by weight, of timber in its cut state (green wood).

Green Wood	Moisture Content
Beach, European	80%
Oak, European	85%
Ash, European	46%
Yew	100%
Pine Pitch	60%
Teak	60%
Elm, Common English	135%
Mahogany, African	65%
Fir, Douglas	58%
Whitewood, Baltic	90%
Cedar, Western Red	50%

20. The Effect of Seasoning Wood

When wood is seasoned as suggested above, the moisture content will gradually reduce over time. The table below indicates the energy released (in both kilocalories per kilogram, and British Thermal Units) and the water content of various stages of the seasoning process.

Seasoning	kC/kg	Btu's	Moisture
Shortly after felling	1700	3060	40-60%
Seasoned one winter	2300	4140	30-40%
Seasoned one summer	2900	5220	18-25%
Seasoned several years	4000	7200	10-15%

21. Burning your Yeoman Stove

Build the fire using kindling material as above. Open all **air controls** fully, light the fire at the front. When the flue is cold it may be best to leave the doors slightly ajar, for a few minutes do not leave the stove burning unattended with the doors open.

As the fire begins to take hold add more fuel, the stove will take approximately 10-15 minutes to get up to a reasonable temperature. This time will be taken to warm the flue and make the draught perform correctly in the chimney.

Once the stove is burning fully at higher temperatures and there is a good amount of heat in the bed of the fire, the **primary air controls** on the door of the stove can be closed (experience will tell you how much to close these controls, and at what stage). When the stove is fully up to working temperature and the primary air is minimised or eliminated then your Yeoman Stove is starting to work efficiently.

If the stove is being used to burn solely wood then it will probably be sufficient to use the top **secondary air (air wash)** only. This method of burning will encourage the process to be cleaner and more efficient. When burning wood with a mix of coal it may be necessary to leave the **primary air** open slightly depending on the fuel and mix ratio. Again this will become more apparent as experience is obtained. The reason for this additional air is that most solid fuels require some 'up-draught' to burn correctly.

Though some lively fuels will be found to require very little. When the fire is being controlled by **secondary air**, secondary combustion will be seen to take place. This will be evident by the fire box being filled with flames and the gases in the fire box appearing to burn. At this point the air wash is really performing, as it should, you will note that the stove burns with clearer glass and by black deposits from previous slow burns can be seen to clear. As well as clearing the glass the air wash will also have the effect on inhibiting dust and ash from being deposited on the glass, thus improving the overall view of the fire within the stove.

If the stove is producing too much heat for your convenience, the most practical way in which to regulate this is by using less fuel. i.e. rather than filling the stove and burning it inefficiently with the **secondary air** partially closed, it will be more efficient to add less fuel and burn with the **secondary air** active. If the stove is burned whilst starved of air, high combustion temperatures will not be achieved, and clean burning will not take place. This will be evident by a more orange (sooty) flame and carbon deposits on the glass (blackening).

High combustion temperatures are the key to clean and efficient burning of your Yeoman Stove, so it is far more beneficial to add many small loads of fuel to the fire rather than smothering the fire by adding one large load. Adding fuel in one large batch tends to have the effect of removing heat from the core of the fire. Adding cold wet wood is also a formula for low combustion efficiency, smoke emission, tar production, and an immediate blackening of the window.

INSTALLATION & USER INSTRUCTIONS

A good tip when refueling the stove is to pull forward the existing burning fuel and add new cold fuel to the rear.

22. Fuel Types

To ensure satisfactory performance of your Yeoman stove it is important to use fuels that are of a suitable size and type, we therefore recommend that you use only fuels that are Hetas approved for the use in closed appliances.

Flues should be inspected frequently, and fuels impregnated with oil not used. Consult your coal merchant for more comprehensive information.

23. Installation

Remove the log retaining bar

Remove the drop in front plate (below the door/s).

Place the handed side plates in position so they rest against the side. Forming a ledge for the grate to sit on.

Fit the grate onto the sideplates ledge.

The ashpan will then slide between the grate supports.

Replace the deepening bar (supplied with kit) then the log retaining bar (spikes up) on top.

Refit front drop in plate.

24. Operation

Using the tool supplied with the kit, remove the front drop in plate and put to one side, place the tool into the centre hole in the ashpan and lift out. Empty the ashpan of ash (being very careful whilst carrying hot ashes) replace the ashpan between the grate supports and finally replace the front drop in plate

25. Overnight Burning

If you fill your Yeoman Stove completely with fuel last thing at night, and close down all air controls, it may be possible to keep the stove alight through the night. This will depend on many factors, the most important being the flue draught.

26. Care and Maintenance

When the stove is to be left for long periods without burning (i.e. the summer months), remove all of the ash and spent fuel. Leave the doors slightly ajar to prevent the build up of rust due to condensation within the appliance and chimney also to allow the chimney to 'Breath.'Yeoman stoves also recommend that you grease the door mechanism with copper ease.

This is also a good time to give your Yeoman Stove a thorough clean and inspection.

We do recommend that the door and glass seals are replaced once a year, by doing this it will ensure that the screws holding the glass clips will be easily removed in the event of a broken panel of glass and your stove is operating at peak performance.

The paint finish is of a matt texture and requires to be brushed down with a soft brush or non-fluff duster.

Water, damp cloths or any cleaning agents should not be used on the painted surfaces.

To revitalise your stove a further coat of paint may be applied using the Yeoman Stove Paint. This paint is the same as the original finish and can be supplied through your local authorised dealer in the form of an aerosol.

Yeoman Stove Fire Resistant Gloves are available in the same manner to assist in the operation of your stove controls.

The rope seals around and between the doors may periodically need renewing. Kits are available from your stockist, containing the correct length of rope, cut and sealed, as well as the correct heat resistant adhesive for the application.

When changing the rope seals it is important to make sure that the casting is clean before applying fresh adhesive – this is best done by the use of a wire brush and / or abrasive paper.

Yeoman Stoves glass cleaner is also available for the removal of stubborn marks and ash from the glass of your stove.

If you have the misfortune to break a piece of glass, replacements are available through your stockist. The correct ceramic glass should be used, as standard domestic glass will not withstand the high temperatures and could prove to be dangerous. The glass panels are easy to fit, attached only by four clips each held in place by an individual screw.

27. Optional Extras

Brass Knobs (YC00628&YC00728)

Solid brass knobs are available as a direct replacement for your standard cast door knobs.

Damper Blade and Spindle (Butterfly and Spindle) (YA00321) – are available for fitting in the flue pipe.

If it is found that excessive flue draught exists then a damper blade and spindle may be purchased. This item is easily fitted into the pre-drilled holes in the flue spigot. This can quite readily be carried out after full stove installation has taken place. As an alternative or in addition it is possible that a draught stabiliser be fitted into the chimney. Please consult your supplier or installer if you have any further questions about this procedure.

Sparkguard. (YB00059)

Allows the stove to be used with the doors open.

INSTALLATION & USER INSTRUCTIONS

28. Spare Parts and Part Numbers

A selection of the spare parts that are available and their associated part numbers is given on the exploded diagram of your Yeoman Stove. The various configurations of stove are shown.

29. Water Heating

Water Heating installations must be carried out by a competent person in conjunction with the requirements as laid down in the following regulations and standards, or superseded amendments:

- The Building regulations
- The local water authority bylaws
- IEE wiring regulations
- B.S.5449:1 (for small bore and microbore central heating systems)
- Any local authority regulations.

B.S.5449:1 gives detailed recommendations of water circulation systems, However, three basic systems are shown in figures 1, 2 and 3.

Dependant on which stove model is selected, the system may be installed on a gravity system, gravity primary pumped or fully pumped with gravity by-pass.

This manual can only advise on basic information. A qualified and competent engineer should be consulted on the installation requirements and used for the installation of the system.

30. General Notes

1. Gravity installations must provide an incline of horizontal pipes of at least 5mm/1000mm (i.e. 5mm/1m).
2. Horizontal gravity inclined flow pipes must be 1 inch (28mm). Reductions may be made in vertical pipes.
3. Radiators larger than 5ft are to be connected diagonally with respect to radiators and gravity systems i.e. gravity heat sink radiators.
4. It is advisable to fit an adjustable circulating pump of which the rate of flow can be adapted to the actual requirements. The pump can be fitted to the return or flow pipe depending on the system design. We recommend that isolation valves be fitted such that the pump can be removed and repaired in the event of a break down.
5. **Cistern.**
 - i) Overflow minimum 22mm.
 - ii) System cold feed minimum 22mm copper and ensure it is the last connection on boiler common return.
6. Minimum air gap 25mm overflow to end of vent.
7. Minimum air gap 25mm overflow to water level (normal run).
8. **Vent.**
 - i) minimum 22mm.
 - ii) Air separation device should be fitted.

9. Heat Sink Circuit (slumber circuit).

- i) Must cater with the minimum heat output slow running.
- ii) No hand operated or automatic closing valves to be used

10. Pump static head should be a minimum of 1.5 meters. i.e. Height between cistern (cold feed tank) fall level and centre line of pump position. This prevents cavitation occurring with the pump.

31. Fitting Electrical Controls

Gravity system primary pumped radiators. A time clock control can be installed to activate the water-circulating pump. This will also control the priority of heat to either hot water or hot water and central heating.

We recommend the use of heat sensor controls for the hot water system. This could take the form of a thermostat coupling from the flow and/or return. This would have the effect of overriding the manual pump switch and maintaining a constant acceptable temperature in the boiler and provide a gross heat-sink should over-firing occur, even when the pump is switched off.

The flow temperature of the system should never be allowed to drop below 55°C[†], with a maximum temperature of 90°C. The system should ideally operate between 80°C and 60°C with an average temperature of 70°C. Therefore we recommend a thermostat on flow rated at 90°C and a return flow thermostat rated at 55°C.

† Large quantities of low temperature water passing through the boiler will cause condensation. Note – it is a requirement of the stoves warranty that at minimum a low temperature thermostat is fitted. We recommend the use of fluid filled thermostats and recommend that bi-metal thermostats not be used.

Fully pumped system.

As the stove produces heat at all times, when alight, the system should be installed as shown for Integral stove types.

Hot Water Storage Tank.

It is recommended that an indirect 190 litre (40 gallon)^{††} or larger storage cylinder be used.

Furthermore, the cylinder should be of a double feed type complying with B.S.1566 Part 1 Type 10: or regulations relevant to area of installation.

The Tank should be lagged and fixed vertically and as near as possible to the appliance, but with sufficient height to allow gravity flow. In combined systems, the water draw off pipes to the taps must be dead leg connections from the vent expansion pipe.

INSTALLATION & USER INSTRUCTIONS

†† It is recommended that the hot water cylinder capacity is at least 13 litres per kW of water heating output. For example 13 x 11 = 143 litres (37 gallons). However, if a heat sink is below the recommended output a traditional cylinder with at least 40 gallons should be fitted.

Drain Points.

The water circuit must have sufficient stopcock; isolation taps and drain points to enable removal of all water should the need arise.

Electrical Supply.

Electrical connections must be installed in accordance with current Wiring Regulations from Building Regulations and any Local authority Regulations.

The method of connection to the mains electrical supply should facilitate complete electrical isolation. Fused double pole switch having a contact separation of at least 3mm serving only the appliance may be used. The point of connection to the mains should be readily accessible and adjacent to the appliance.

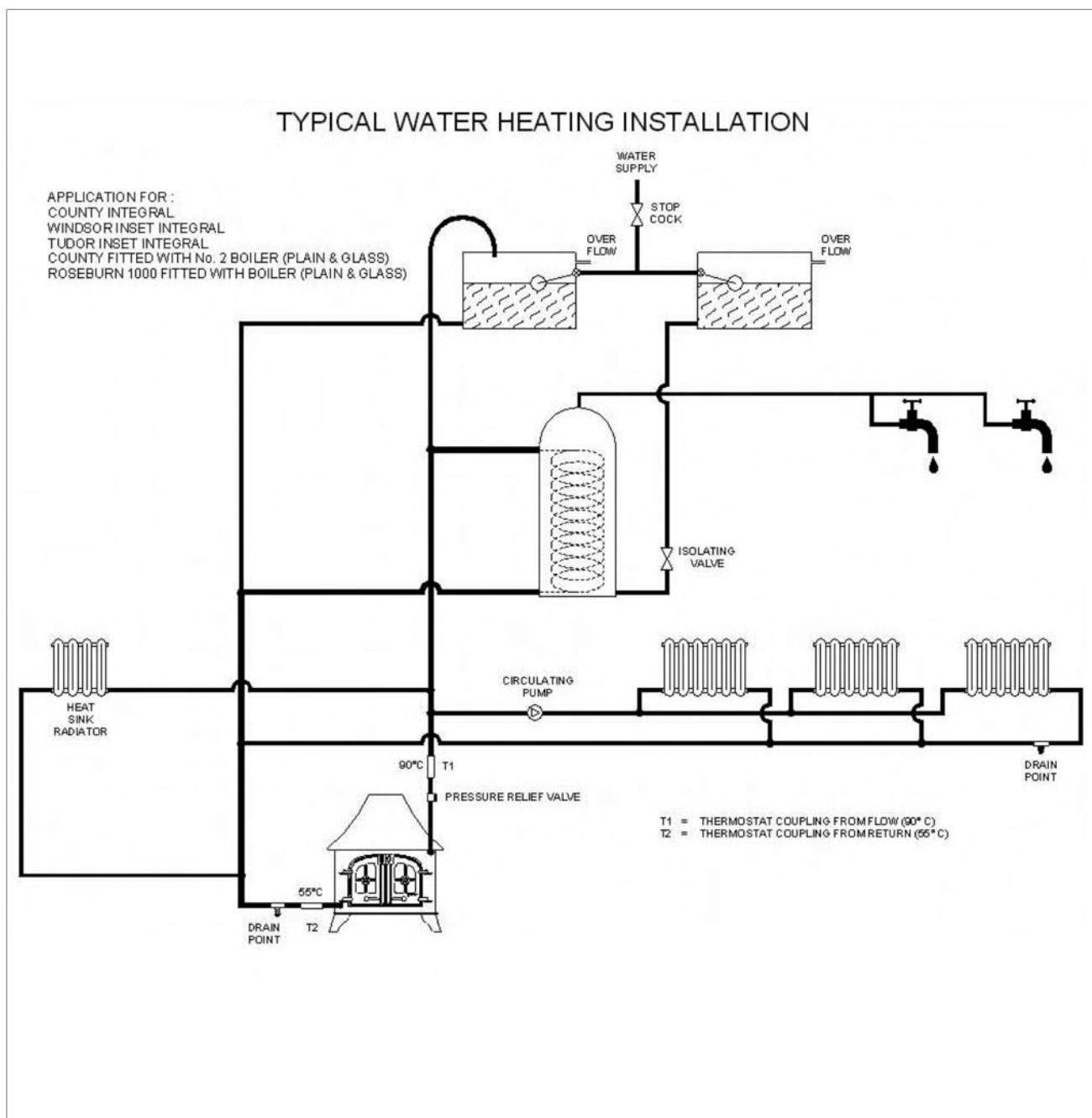

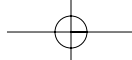

INSTALLATION & USER INSTRUCTIONS

GUARANTEE

1. All Yeoman stoves are guaranteed for t w o years against faulty components form the date of purchase.
2. The guarantee is given subject to the following provisions;
 - a)That the installation, and any additional work to either flue or combustion chamber, is carried out by a suitably qualified person.
 - b)That the fireplace and flue installation conforms to the relevant building regulations and British standards where appropriate.
 - c)That our instructions for installation, servicing and cleaning are followed. This guarantee does not cover mishandling.
 - d)That any part or parts replaced under guarantee are returned to us postage paid for inspection, via your Yeoman dealer.
 - e)That our liability is limited to the free replacement part or parts affected. No claims for any other work will be considered unless agreed by Yeoman Stoves management.
 - f)This guarantee does not cover normal wear and tear.
 - g)This guarantee does not cover glass or any seal replacement, firebricks, baffles or paint finish.
3. Yeoman stoves are guaranteed via the stockist from whom they were purchased, and not directly by Yeoman. In the event of any guarantee claims, you should therefore contact the stockist from where you purchased the stove.

This does not effect your statutory rights.

For your records and to assist us in any guarantee claim please make a note of the following;

Stockist from whom purchased:

Name. _____

Address _____

Tel _____

Installed by: _____

Name _____

Address _____

Tel _____

Date Installed _____

Model Type _____

Serial No. _____

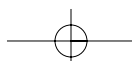

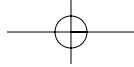

NOTES

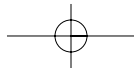
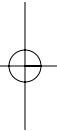
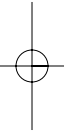

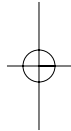
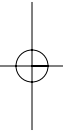
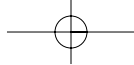

YEOMAN STOVES

A division of Stovax Ltd

Falcon Road, Sowton Industrial Estate, Exeter, EX2 7LF

Tel 01392 . 474500 Fax 01392 . 219932

www.yeoman-stoves.co.uk

Email: yeoman@stovax.com

