



Better than you ever imagined

Users Instructions. Rayburn Heatranger 355SFW Solid Fuel and Wood Burning Cooker



Consumer Protection Act 1987

As responsible manufacturers, we take care to make sure that our products are designed and constructed to meet the required safety standards when properly installed and used.

IMPORTANT NOTICE: PLEASE READ THE ACCOMPANYING

WARRANTY: Any alteration that is not approved by Aga, could invalidate the approval of the appliance, operation of the warranty and could also affect your statutory rights. Use only authorised replacement parts.

All local regulations including those referring to national and European standards need to be complied with when installing the appliance.

Control of Substances - Health and Safety

Important

This appliance may contain some of the materials that are indicated.

It is the Users/Installers responsibility to ensure that the necessary personal protective clothing is worn when handling, where applicable, the pertinent parts that contain any of the listed materials that could be interpreted as being injurious to health and safety, see below for information.

Firebricks, Fuel beds, Artificial Fuels - when handling use disposable gloves.

Fire Cement - when handling use disposable gloves.

Glues and Sealants - exercise caution - if these are still in liquid form use face mask and disposable gloves.

Glass Yarn, Mineral Wool, Insulation Pads, Ceramic Fibre, Kerosene Oil - may be harmful if inhaled, may be irritating to skin, eyes, nose and throat. When handling avoid inhaling and contact with skin or eyes. Use disposable gloves, face-masks and eye protection. After handling wash hands and other exposed parts. When disposing of the product, reduce dust with water spray, ensure that parts are securely wrapped.

INTRODUCTION

The Rayburn 355SFW has been designed to burn a variety of solid fuels and thereby provide heating facilities for cooking, domestic hot water and central heating.

The thermostatically controlled hot water boiler can be operated independently of the cooker and will provide hot water for central heating and domestic use (normal setting for winter usage), whilst manually operated spinwheel control on the front of the ashpit door will provide heat for cooking and domestic hot water (normal setting for summer usage).

The cooker/boiler flueway damper knob on the centre front of the cooker below the top plate requires to be set in conjunction with the flue chamber damper to obtain the appropriate service required from the appliance.

PREPARING COOKER FOR USE

FIREBRICK POSITIONS

The Rayburn 355SFW is delivered complete including a set of boiler removable firebricks where positional location determines the amount of hot water supplied in winter and summer seasons.

The oven side and firebox front firebricks are permanently fixed with fire cement and should remain in their positions at all times.

The two boiler face side bricks and boiler face rear brick are so located for summer use when hot water, for domestic use only, will be provided.

For winter use or central heating facilities the boiler face rear brick is removed and the two boiler face side bricks are transferred to locate on/over the oven side bricks.

Secondary Air Slide.

On opening the firedoor the secondary air slide is seen on the base of the opening and should be set according to the fuel being used as follows:-

<u>WARNING</u>
THE ASHPIT AND FIREBOX DOORS MUST BE LOCKED CLOSED AT ALL TIMES DURING NORMAL USE, EXCEPT WHEN LIGHTING OR RE- FUELLING.

Air Slide Open - wood logs

Air Slide Closed - manufactured smokeless fuels

This appliance has been tested using manufactured briquetted smokeless fuel (Taybrite and Ancit) for closed appliances sized between 20g and 140g. Other fuels are commercially available and may give similar results.

WARNING: HOT SURFACES, use the tool supplied to operate this appliance. It is recommended to use the heatproof glove supplied when raising the dome lids to use the hotplate. Replacement gloves can be obtained from the Aga Shop.

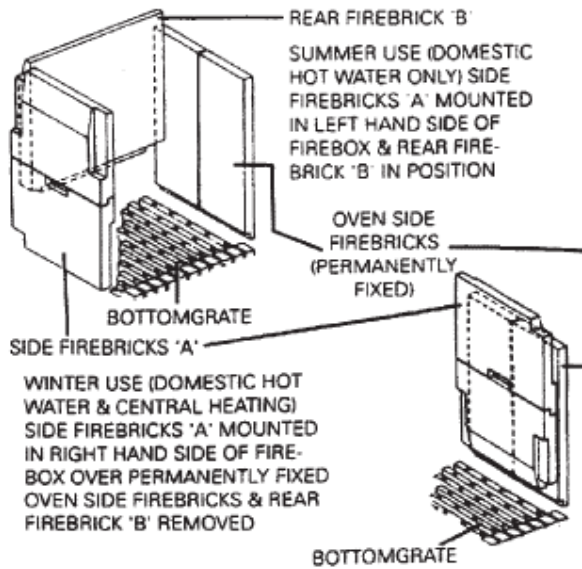

Fig. 1

raywarranty@aga-web.co.uk

RECOMMENDED SOLID FUELS

MANUFACTURED - SUNBRITE SINGLES, SUNBRITE DOUBLES, COALITE, PHURNACITE and SUPACITE. NATURAL - ANTHRACITE LARGE & SMALL NUTS, SELECTED HOUSECOAL (TREBLES/LARGE NUTS AND DOUBLES/NUTS), TAYBRITE, COKE.

PETROLEUM COKE MUST NOT BE USED.

Oversize fuel lumps should be broken down to size. Stones and other foreign bodies should be removed when fuelling.

Fuel should be stored under cover and ventilated, particularly manufactured fuels which must be kept dry. Wet kitchen refuse should not be burned.

Any air inlet grilles must be maintained so that they are free from blockage.

Failing to maintain your cooker properly can lead to a chimney fire. Chimney fires occur when combustible deposits on the inner walls of the chimney ignite. These combustible deposits, called "creosote", are a natural byproduct of wood burning. A fire hazard exists if 1/4" of creosote (or more) coats the inner walls of the chimney.

DOOR OPERATION

OVEN DOOR OPERATION - SEE [FIG. 2](#)

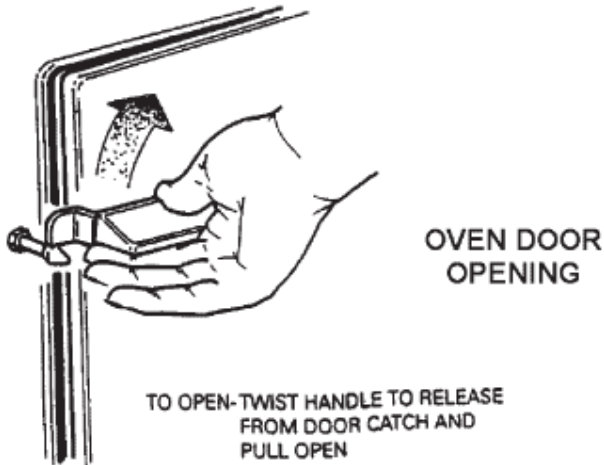

Fig. 2 DESN 512979

To open the doors. Twist the handle slightly to lift up the door catch from the locking spindle and pull the door open.

To close the doors. Gently push the door shut until the door catch makes contact with the locking spindle.

FIRE DOOR OPERATION - SEE FIG. 3

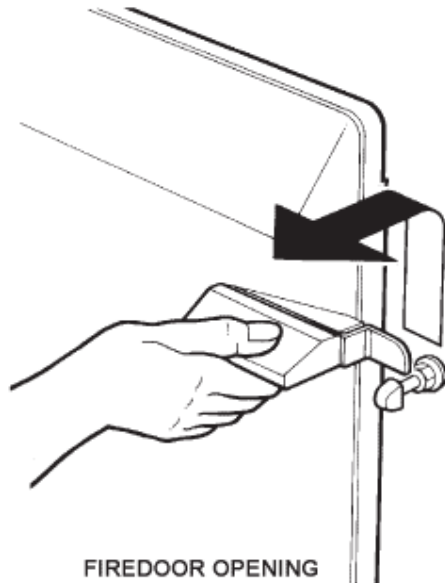

Fig. 3 DESN 512978

To open the door. Lift the door by the handle and pull forward.

To close the door. Lift the door up by the handle and push to shut.

THE FIREDOOR MUST BE LIFTED SLIGHTLY WHEN OPENING AND CLOSING, OTHERWISE DAMAGE TO THE DOOR CATCH WILL OCCUR.

DO NOT SLAM THE FIREDOOR SHUT!

FUELLING WITH WOOD OR PEAT

The cooker will satisfactorily burn wood logs, blocks or peat briquettes, but logs should be perfectly dry in order to obtain the best cooker performance and minimise the deposits of creosote. Wet logs may also provide overnight banking problems and the following hints are recommended:-

- a) Burn dry soft wood in the day time and dry hard wood overnight if possible.
- b) Avoid using 'green' wood on overnight banking as creosote deposits will be increased.
- c) Using hard wood in the day time will give prolonged burning but heating response is slower.
- d) Wet kitchen refuse should not be burned.
- e) Before refuelling, open the flue chamber damper to its full extent and fill the firebox up to the bottom of the firedoor opening, ensuring the secondary air is at fully open.
- f) To obtain the optimum burning rate with wood burning fuels only, a grate baffle should be located on the top face of the reciprocating bars at the rear of the firebox. See diagram. Grate riddling is not required when burning wood where poking will normally suffice. Always remove this grate baffle when burning solid mineral fuels.

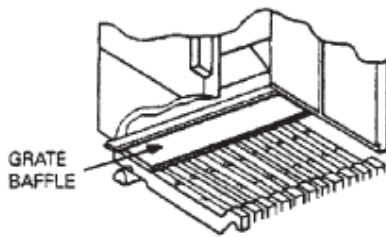

Fig. 4

FAMILIARISE YOURSELF WITH THE COOKER

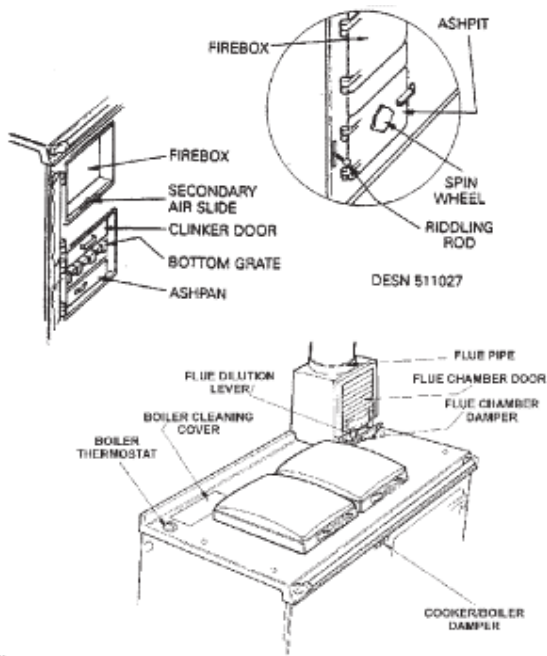

Fig. 5 DESN 511028B

LIGHTING THE FIRE

All Fuels using Wood and Paper

- a) Check the flue pipe is free of blockage.
- b) Open firebox door.
- c) Open ashpit door.
- d) De-ash ([Fig. 8](#)) and remove dead fuel from bottomgrate (lift off clinker door above the bottomgrate ([Fig. 10](#)), rake fuel into ashpan replace clinker door).
- e) Remove ashpan, empty and replace ([Fig. 9](#)).
- f) Open flue chamber damper to maximum ([Fig. 7](#)).
- g) Flue dilution lever fully to 'left' (flue chamber door closed, [Fig. 7](#)).
- h) Lay a liberal supply of wood and paper on top of the bottomgrate bars together with a small quantity of fuel and light.
- i) **Close and lock the ashpit door** with the spinwheel control open.
- j) **Close and lock the firedoor.**
- k) With fire established, open firebox door and fill firebox with fuel. Check secondary air slide setting ([Fig. 6](#)). **Close and lock firebox door.** Push flue chamber damper back to position which has been found to give desired burning rate.

All fuels Using a Gas Poker

- a) Check flue pipe is free of blockage.
- b) Open firebox door.
- c) Open ashpit door.
- d) De-ash ([Fig. 8](#)) and remove clinker door ([Fig. 10](#)). Insert flat bayonet type gas poker on top of bottomgrate bars.
- e) Remove ashpan and empty ([Fig. 9](#)).
- f) Open flue chamber damper to maximum ([Fig. 7](#)).
- g) Flue dilution lever fully to 'left' (flue chamber door closed, [Fig. 7](#)).
- h) Lay a 75-100mm 3"-4") shallow depth of fuel onto the bottomgrate and light gas poker.
- i) Close the ashpit and firebox doors as far as possible-spinwheel control open.
- j) When the fuel is well alight, extinguish and remove the gas poker, replace the clinker door and ashpan, **close and lock the ashpit door** with the spinwheel control open. close the firedoor.
- k) With the fire established open the firebox door and fill firebox with fuel. Check secondary air slide setting ([Fig. 6](#)). **Close and lock the firebox door.** Push the flue chamber damper back to position which has been found to give best results. Set spinwheel control to give desired burning rate.

COOKER CONTROL

Cooking Only - All Fuels

- a) The fire is controlled by using the spinwheel on the ashpit door to govern the air supply.
- b) The adjustable flue chamber damper is for reducing the chimney draught, and the more it can be closed, the easier the cooker is to control. The line markings on the flue chamber enable you to repeat the best settings to suit your chimney, from No.1 in a closed position to No.6 fully open.
- c) Control over the direction of the flue gases is obtained by the setting of the cooker/boiler damper.

Set the cooker/boiler damper knob on the front of the cooker to 'C' and the boiler thermostat knob on the rear left hand corner of the top plate, to its minimum setting.

- d) Thermostat set at No.1 as domestic hot water is obtained when cooking.

NOTE: INTERMEDIATE SELECTIVE SETTINGS OF THE COOKER/BOILER DAMPER KNOB AWAY FROM 'C' WILL PROGRESSIVELY RESTRICT THE AMOUNT OF HEAT TO THE TOP OF THE OVEN AND INCREASE THE AMOUNT OF HEAT INTO THE BOILER UNTIL THE KNOB IS POINTING TO SYMBOL 'H' FOR MAXIMUM WATER HEATING. IN THIS POSITION, THE MINIMUM PROPORTION OF HEAT IS DIRECTED TO OVEN HEATING. ALTHOUGH THE OVEN WILL STILL GET HOT.

CONTROL SETTING

Cooking Only - All Fuels

Set the spinwheel open. The precise amount will be shown by experience with the appliance.

After setting the cooker/boiler damper knob to 'C', set the flue chamber damper fully open after refuelling and reset to position which has been found by practical experience to give the best results. Do not try to obtain a fast increase in temperature by opening flue chamber to its fullest extent. This results in most of the heat being wasted up the chimney.

Avoid excessive fire temperatures with solid fuel - they are unnecessary and may do serious harm to the cooker. The first symptoms of an overheated cooker is the formation of clinker (melted ash) which will damage the fire bricks.

Damaged firebricks should be replaced as soon as possible but may be temporarily repaired with fire cement.

Keep the ashpit door securely closed with the front plate catch.

OVERNIGHT BANKING

Solid fuel

The appliance is designed for continuous burning and the best results will only be obtained if it is allowed to burn overnight. It is no more expensive in fuel costs.

Last thing at night, de-ash the fire, empty the ashpan and fully refuel but do not overload.

Ensure that the firebox and ashpit doors are securely closed, and after closing the spinwheel, re-open it a quarter of a turn.

Set the boiler thermostat knob to its minimum setting and close the flue chamber damper plate to No. 1 setting. Set the cooker/boiler chamber knob to 'C' to obtain optimum heat into oven and hot plate.

NOTE: THE BEST POSITION FOR THE FLUE CHAMBER DAMPER CAN BE FOUND ONLY BY EXPERIMENT BUT ALWAYS TRY THE LOW SETTING FIRST.

In the morning, open the spinwheel three complete turns, the flue chamber damper to maximum and riddle the fire. When it is burning brightly, close the flue chamber damper, but do not refuel before use if the hotplate is required immediately.

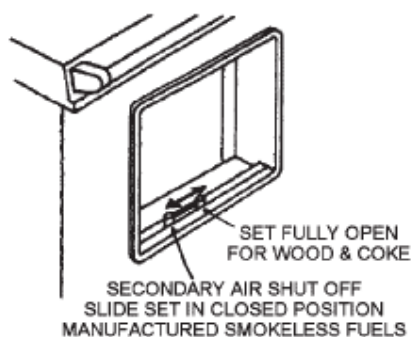

Fig. 6

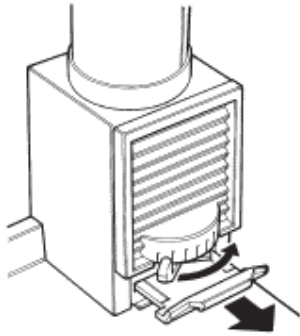

Fig. 7

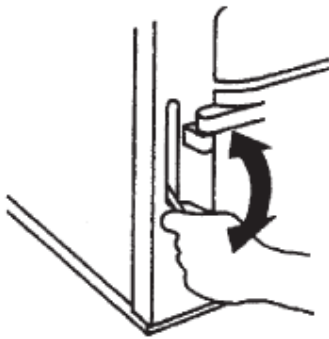

Fig. 8

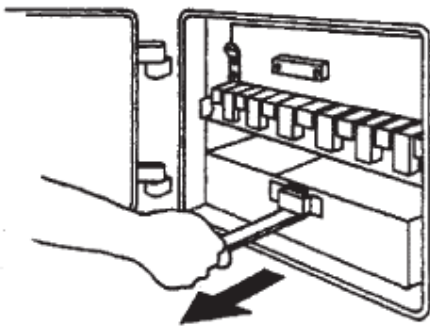

Fig. 9

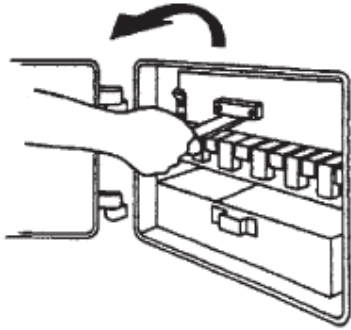

Fig. 10

BOILER CENTRAL HEATING THERMOSTAT SETTING

All Fuels.

Set the cooker/boiler damper knob 'H'.

Close spinwheel.

To regulate burning, set the boiler thermostat knob to '8' (high) or minimum rate '1' (low).

Adjust as required to suit desired water heating.

Overnight banking and daytime slow burning should be obtained with the boiler thermostat knob set at '1' to give extended burning.

Wood burning

Some woods are more difficult to burn therefore it may be necessary to open the spinwheel in addition to the thermostat to obtain the desired results. The spinwheel must be closed as appropriate. Do not leave the cooker for extended periods with the spinwheel open as the cooker may overheat and cause damage.

In some circumstances it may be possible to overheat the appliance and the water inside will boil. This will be evident by the sound of a knocking noise coming from the appliance and pipes around the house. If this occurs close off all air controls and manually start the central heating pump if fitted. Opening the oven doors and hotplate covers will help to release heat from the appliance. Be aware that steam and boiling water will be expended from any open vent from the heating system probably in the roof space at the expansion tank.

In the unlikely event that the appliance is not operating in freezing conditions the water must be drained from the boiler to prevent frost damage.

OVERNIGHT CENTRAL HEATING

Solid Fuel

The appliance may be operated overnight for the purpose of selected central heating when inclement weather conditions occur.

Set the cooker/boiler damper knob to 'H' after refuelling etc. and the boiler thermostat knob to No. 2 with the flue chamber damper set at minimum. The spinwheel should be closed and about four radiators can be run overnight under these conditions.

NOTE: THE HOTPLATE AND OVEN TEMPERATURE WILL BE CONSIDERABLY LOWER AND EXTENDED TIME WILL BE NEEDED TO HEAT UP THESE FEATURES. DO NOT FORGET TO RE-SET THE COOKER/BOILER KNOB TO 'C' FOR COOKING AFTER OVERNIGHT USE.

OVERNIGHT BANKING

Wood

The appliance is designed for continuous slumbering overnight for up to a maximum of 12 hours depending on the type of dry wood being used. Last thing at night, open the flue chamber damper. de-ash the fire, empty the ashpan and fully refuel.

Ensure that the firebox and ashpit door are securely closed, close the spinwheel tight and the flue chamber damper is set to No.1.

Set the boiler thermostat knob to its minimum setting and the front damper knob to 'c'.

Turn the flue dilution lever (See [Fig. 7](#)) from left to right hand so that the flue chamber door opens at the bottom and minimise burning rates.

NOTE: THE PRECISE AMOUNT OF OPENING DEPENDS ON THE CHIMNEY DRAUGHT, THE TYPE/CONDITION OF WOOD TO BE BURNT AND THIS MAY TAKE 2 OR 3 DAYS TO ASCERTAIN.

1. If the fuel in the firebox is exhausted prematurely, the overnight chimney draught must be reduced by increasing the opening setting of the flue chamber door, using the flue dilution lever.
2. If the fuel does not burn but 'dies out', the draught should be increased by reducing the opening setting. of the flue chamber door, using the flue dilution lever.

Following overnight banking, the flue chamber door must be closed, the spinwheel and flue chamber damper opened and the fire refuelled.

Immediately the new fuel has caught alight, riddle the fire and close the flue chamber damper.

NOTE: BUILD-UP OF CREOSOTE DEPOSITS IN THE FLUE AND CHIMNEY CAN IN TIME, LEAD TO CHIMNEY FIRE.

THESE DEPOSITS CAN BE PREVENTED BY THE REGULAR USE OF A PROPRIETARY BRAND OF CHEMICAL CREOSOTE REMOVE CHIMNEY CLEANER SUCH AS "ATTACK" WHICH REDUCES THE ADHESION STRENGTH OF THE CREOSOTE DEPOSITS, CAUSING THEM TO FAIL.

IMPORTANT: CHEMICAL CLEANERS MUST NOT BE CONSIDERED AS AN ALTERNATIVE TO CHIMNEY SWEEPING, ONLY AS SUPPLEMENTARY.

TYPICAL WATER TEMPERATURES

Against Thermostat knob settings with Cooker/Boiler Damper at 'H' and Spinwheel closed.

Thermostat Setting No.	Water Temperature (APPROXIMATE)
1	46°C (115°F)
3	54.5°C (130°F)
5	65.5°C (150°F)
8	80°C (176°F)

a) Using the cooker boiler to provide heat for domestic hot water and radiators in the winter, a boiler thermostat setting at No.8 is recommended.

b) Using the cooker boiler for the provision of domestic hot water only, in the summer, a boiler thermostat setting of No. 5 is recommended.

NOTE: TO CONSERVE FUEL, ENSURE THE HOT WATER CYLINDER AND PIPES ARE LAGGED WITH INSULATION.

REFUELLING

The firebox should be filled to the recommended level of the bottom firebox door opening and the firebox door closed.

A correctly fueled fire will last a minimum of 3 hours when burning solid fuel and 2 hours burning wood when maintaining the maximum rated output of the boiler with intermittent cooking periods included.

NOTE: When burning any wood fuels and Sunbrite Coke, the secondary air slide should be set in a fully open position.

A deep bed of newly charged fuel on a low fire will take time before heat reaches the ovens, hotplate and boiler. When burning Coal, Phurnacite and Anthracite, allow several minutes for the new charge to ignite before changing the flue chamber damper setting.

ONCE REFUELLING HAS BEEN COMPLETED, CLOSE THE FIREBOX DOOR IMMEDIATELY AND OPEN ONLY FOR REFUELLING CHARGES.

DE-ASHING

To de-ash, riddle the grate by agitating the riddling handle in an up and down manner 10-20 times to free the grate of ash. See [Fig. 8](#).

ALWAYS DE-ASH BEFORE REFUELLING (SEE '[EXCEPTIONS](#)' BELOW) AT THE FOLLOWING INTERVALS:-

SUMMER USE:

Three times daily at least.

WINTER USE:

Three times daily at least and more often if required.

NOTE: SHOULD THE BOTTOMGRATE DE-ASHING FAIL TO CLEAR AN ACCUMULATION OF STONES, SHALE OR CLINKER, IT MAY BE REMOVED AS DESCRIBED IN SECTION ON REMOVAL OF CLINKER.

Open the ashpit door to give access to the ashpan which must be emptied regularly (See [Fig. 9](#)).

In winter, this may be as much as three times daily depending on weather severity.

The class of fuel and cooker usage govern the frequency of refuelling.

NOTE: DO NOT ALLOW ASH TO ACCUMULATE IN THE ASHPAN UNTIL UNTIL IT TOUCHES THE UNDERSIDE OF THE BOTTOMGRATE BARS OR THEY WILL QUICKLY BURN OUT.

Ensure the ashpan is fully home otherwise the ashpit door may not close and lock completely.

EXCEPTIONS:

WHEN BURNING ANTHRACITE OR PHURNACITE, ALWAYS REFUEL BEFORE EMPTYING ASHPAN AND RIDDLING.

REMOVAL OF CLINKER FROM BOTTOMGRATE

Due to an accumulation of pieces of stone, clinker and shale etc. it may not be possible to pass them through the grate when riddling, and may even cause jamming.

Allow the fire to burn out and then open the ashpit door. Lift off the clinker door (See [Fig. 10](#)) and insert a hooked poker to draw out any offending accumulation. Replace clinker door after use.

The amount of clinker formation is dependent on the heating load or burning rate and should be checked weekly for any build-up. Excessive build-up will lead to a fall in heating output requiring bottomgrate clean-out and reduction in life of the bottomgrate.

USE OF THE HOT PLATE

The best results can be obtained by using machined base utensils. The hottest part of the hot plate is immediately above the fire, the other end being for simmering.

The circular plug in the hotplate (near the flue chamber end) is for flue cleaning and must not be removed for cooking.

Keep the hotplate clean with a wire brush.

NOTE: TO OBTAIN OPTIMUM HOTPLATE PERFORMANCE FOR FAST BOILING OR HOT PLATE COOKING, FUEL THE FIREBOX TO THE BOTTOM EDGE OF THE FIREBOX APERTURE TO A HORIZONTAL LEVEL.

WARNING: THE COOKER TOP PLATE SURFACE AROUND THE HOTPLATE WILL BECOME HOT UNDER USE AND CARE MUST BE OBSERVED. PLEASE REFER TO THE INSTALLATION INSTRUCTIONS REGARDING MINIMUM CLEARANCES TO COMBUSTIBLE SURFACES AND MATERIALS.

USE OF THE TOP ROASTING OVEN

The correct adjustment of the spinwheel and flue chamber damper to obtain the oven temperature required varies with the chimney draught, and can be found only by experiment. The following is a suggested method only, and may need modification to suit local conditions. Suppose an oven temperature for roasting is desired, and that the cooker is idling.

Thoroughly de-ash the fire as described in the respective paragraph, and refuel. Set the flue chamber damper to No.3 setting and open the spinwheel as described under 'CONTROL SETTING'.

As soon as the fire has become red all through, close the flue chamber damper. Do not allow the fire to become white hot.

The temperature of the oven should now rise steadily. When it reaches a point about 30°C (50°F) below that required, close the spinwheel to approximately one turn open. Thereafter control the temperature of the oven by adjusting the spinwheel.

NOTE: THE METHOD SHOULD PROVE SUCCESSFUL IN ALMOST ALL CASES, BUT IF CLOSING THE FLUE CHAMBER DAMPER CAUSES THE FIRE TO SMOKE, IT SHOULD BE OPENED GRADUALLY UNTIL THE SMOKING STOPS.

To reduce top heat in the oven adjust the cooker/boiler damper knob gradually away from symbol 'C'. The oven may be cleaned with a stiff wire brush, when it is very hot.

OVEN TEMPERATURES:-

HOT

220°-260°C (400°-500°F)

MODERATE

150°-200°C (300°-400°F)

SLOW

90°-150°C (200°-300°F)

Check with pointer
reading on oven door
thermometer.

USE OF THE BOTTOM COOKING OVEN

It is not possible to control this oven, but during the course of roasting, sufficient heat input permits simmering of dishes that have been taken from the roasting oven.

OVEN TEMPERATURES:-

Idling 95°C min.

During cooking - 135°C max.

During the cooker idling periods, the oven is ideal for heating plates and keeping food warm.

FLUEWAY CLEANING

WARNING: HOT SURFACES, use the tool supplied to operate this appliance. It is recommended to use the heatproof glove supplied when raising the dome lids to use the hotplate. Replacement gloves can be obtained from the Aga Shop.

Following a prolonged shutdown of the appliance, perhaps after the summer break, ensure the flueway is free from obstruction prior to re-lighting.

When burning coke, anthracite, other smokeless fuels, logs or peat, the appliance flueways should be cleaned on a regular four weekly basis.

When burning bituminous coal, cleaning should be done at weekly intervals.

Prolonged soot formation may result in flueways becoming blocked and could give rise to the release of carbon monoxide, a poisonous gas into the room.

Failure to ensure clean flueways, flue pipes and bends may lead to emission of dangerous gases and an inferior performance from your appliance.

Cooker Flueway - Allow the fire to burn out, open the flue chamber damper to its maximum and remove the flue chamber door.

Turn the cooker/boiler knob to 'C'.

Brush the soot or fly ash from the flue pipe allowing it to fall onto the top of the oven. [Fig. 11.](#)

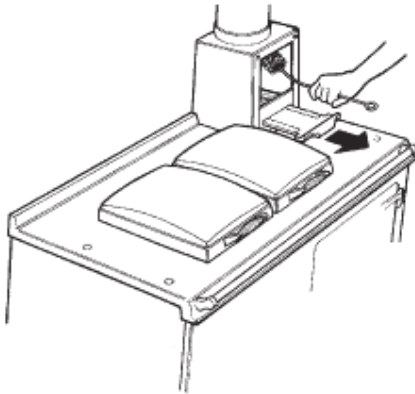

Fig. 11

Remove the hotplate plug and rake the deposits forward, pushing them into the firebox. [Figs. 12 & 13.](#)

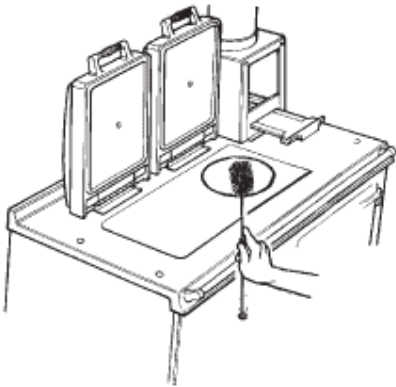

Fig. 12

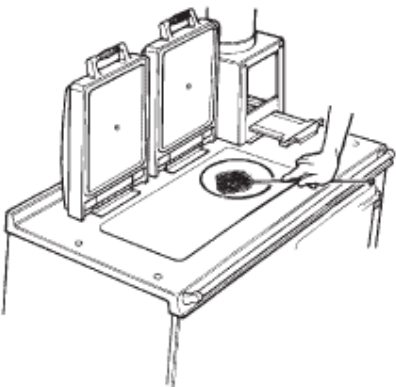

Fig. 13

Boiler Flueway - Set the cooker/boiler damper knob to 'H' and remove boiler cleaning cover in top plate adjacent to boiler thermostat control knob.

Lift out exposed boiler cleaning plate and brush near boiler flueways up and down allowing debris to fall into the firebox. [Fig. 14.](#)

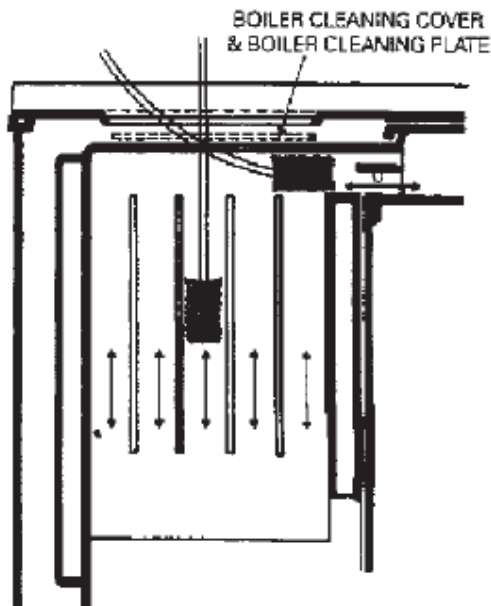

Fig. 14

Clean boiler flue outlet by inserting brush horizontal at right hand of boiler aperture below top plate.

Push brush above and below the boiler damper so that flash etc. is pushed onto oven top. Insert rake through hotplate plug aperture and pull deposits into firebox (after resetting cooker/boiler damper knob to 'C').

Replace flue chamber door and hotplate plug and riddle the bottomgrate thoroughly to clear the bottomgrate ready for relighting.

NOTE: THE APPLIANCE IS DESIGNED AND INTENDED TO BE UNDER CONTINUOUS FIRING BUT IF IT IS NOT IN USE ASHPIT AND FLUE CHAMBER DOORS SHOULD BE LEFT OPEN TO ENSURE FREE PASSAGE OF AIR THROUGH THE APPLIANCE AND AVOID CONDENSATION PROBLEMS.

CHIMNEY SWEEPING

Sweep annually and inspect soot box at 3 monthly intervals and remove any deposits.

NOTE: SWEEPS BRUSHES MUST BE OF THE TYPE WITH WIRE CENTRES AND GUIDE WHEELS.

CHIMNEY FIRES

Prevention: Chimney fires do not occur in clean, intact, properly installed chimneys. Have a professional chimney sweep clean and inspect your appliance at least once a year. More frequent cleanings may be required, based on the type of fuel burned, the type of appliance, and the frequency of use. In general, an older appliance or one that is used frequently, will require more than one clean per year.

Detection: The first indication of a chimney fire is usually the noise - a roaring sound grows louder as the fire's intensity increases. Clouds of black smoke and sparks will be seen exiting the top of the chimney; in severe fires, flames can extend several feet about the chimney.

Action: In case of a chimney fire follow these steps but do not put yourself or others in peril:

1. Call the fire brigade immediately.
2. Get everyone out of the property.
3. Close down the air supply to the appliance i.e. the primary air spinner and the flue damper. Limiting the fire's air supply will reduce its intensity. If there is a damper in the chimney connector, plug or close the opening.
4. If a fire extinguisher is available, open the appliance door just enough to insert the nozzle of a 10lb, dry chemical fire extinguisher rated for Class ABC fires. Discharge the entire content of the fire extinguisher into the appliance and shut the door.
5. If possible, wet down the roof and other outside combustibles to prevent fires ignited by shooting sparks and flames.
6. Closely monitor all combustible surfaces near the chimney. During severe chimney fires, these surfaces can become hot enough to ignite.

After a chimney fire, have the chimney inspected by a professional chimney sweep or cooker installer.

CLEANING

Surface blemishes caused by spillage on the gloss enamel are easier to remove when the cooker is cool, and a damp cloth is usually all that is necessary.

This should not be done whilst the cooker is hot.

DO NOT USE ABRASIVE PADS, OVEN CLEANER, OR CLEANERS CONTAINING CITRIC ACID ON ENAMELLED SURFACES.

IMPORTANT NOTE: Aga recommend Vitreous Enamel Association approved cleaners for cleaning the vitreous enamelled surfaces of this product.

But they are unsuitable for use on: chrome and stainless steel components, including the hand-rails and their brackets.

The insulating covers should be cleaned regularly with a NON-ABRASIVE mild detergent, applied with a soft (coarse free) cloth and lightly polished up afterwards with a soft (coarse free) duster or tissue to bring it back to its original lustre.

TO REPLACE BOTTOMGRATE BARS

Allow fire to burn out first then open the ashpit door and lift off the clinker door. Remove dead fuel with hooked poker into ashpan and then lift up each individual bar, pulling forward to remove.

NOTE: THERE ARE TWO TYPES OF BARS ASSEMBLED AND THE REPLACEMENT BARS SHOULD BE CHECKED AGAINST 'REPLACED' BAR BEFORE REPLACEMENT.

FIREBRICK REPLACEMENT

The firebricks fitted to the Rayburn 355SFW are of first quality manufacture, and providing the cooker has been installed and used correctly will have a reasonable life. They are, however, expendable items and in time will require renewal.

Replacement bricks either in sets or singly can be obtained from your Rayburn distributor. Always quote the manufacturing number.

The manufacturing number, which will be found fixed to the appliance, should be quoted if any question arises in connection with the Rayburn 355SFW Cooker.

HOT WATER SERVICE

The cooker has been designed to provide a satisfactory supply of domestic hot water with or without a limited amount of heating with a normal day's cooking providing the cooker is kept alight overnight and the system complete with lagged cylinder conforms to the installation instructions.

SERVICING

Always use a qualified service/heating engineer when servicing is required. Use only authorised replacement parts. Do not make unauthorised modifications.

FUME EMISSION WARNING

Properly installed and operated, this cooker will not emit fumes.

Occasional fumes from de-ashing and re-fuelling may occur but persistent fume emission must not be tolerated.

If fume emission does persist, then the following immediate action should be taken:-

- a) Open doors and windows to ventilate room.
- b) Let the fire out or remove lit fuel from cooker.
- c) Check for flue or chimney blockage, and clean if required.
- d) Do not attempt to relight fire until cause of fume has been identified, and if necessary, seek professional advice.

SPARES LIST

Part Number	Description	No Reqd
QWX	Boiler Thermostat	1
1/16182 T	Bottomgrate bars top	6
1/16182 B	Bottomgrate bars bottom	5
3/16272	Oven side firebricks	2
4/16273	Firebox side top firebricks	1
3/16271	Front firebrick	1
3/16274	Removable boiler face	
	rear firebrick	1
3/16275	Removable boiler face	
	side firebrick	2
3/18172	Grate Baffle	1

Replacement parts if required are always available ex-works. Write to us should any difficulty be encountered in obtaining them from your usual supplier.

SMOKE/SMELL EMITTED DURING INITIAL USAGE

Some parts of the cooker have been coated with a light covering of protective oil. During initial operation of the cooker, this may cause smoke/smell to be emitted and is normal and not a fault with the appliance, it is therefore advisable to open doors and or windows to allow for ventilation.

Lift the insulating lids to prevent staining the linings.

**For further advice or information contact
your local distributor/stockist**

With Aga's policy of continuous product improvement, the Company reserves the right to change specifications and make modifications to the appliance described at any time.



Made by The text "Made by" followed by the AGA logo, which consists of the letters "AGA" in a white, bold, sans-serif font inside a black, horizontally-oriented oval.

Manufactured by
Aga