

WARNING

This information is a copy of an original archive, therefore Aga cannot be held responsible for its continued accuracy.

COALBROOKDALE THE LITTLE WENLOCK 3

Operating Instructions for Freestanding Little Wenlock Stove Boiler and Non-Boiler Model

Consumer Protection Act 1987

As manufacturers and suppliers of cooking and heating products, in compliance with Section 10 of the Consumer Protection Act 1987, we take every care to ensure as far as is reasonably practicable, that these products are so designed and constructed as to meet the general safety requirement when properly used and installed. To this end, our products are thoroughly tested and examined before despatch.

IMPORTANT NOTICE: Any alteration that is not approved by Aga-Rayburn, could invalidate the approval of the appliance, operation of the warranty and could also affect your statutory rights.

Control of Substances - Health and Safety Important

This appliance may contain some of the materials that are indicated below. It is the Users/Installers responsibility to ensure that the necessary personal protective clothing is worn when

handling, where applicable, the pertinent parts that contain any of the listed materials that could be interpreted as being injurious to health and safety, see below for information.

Firebricks, Fuel beds, Artificial Fuels - when handling use disposable gloves.

Fire Cement - when handling use disposable gloves.

Glues and Sealants - exercise caution - if these are still in liquid form use face-mask and disposable gloves.

Glass Yarn, Mineral Wool, Insulation Pads, Ceramic Fibre, Kerosene Oil - may be harmful if inhaled, may be irritating to skin, eyes nose and throat. When handling avoid inhaling and contact with skin or eyes. Use disposable gloves, face-masks and eye protection. After handling wash hands and other exposed parts. When disposing of the product, reduce dust with water spray, ensure that parts are securely wrapped.

The appliance user should check with their installer that the chimney has been examined and confirmed for soundness, the chimney has been swept prior to the stove installation and is free of any obstructions.

The freestanding Little Wenlock stove with boiler is intended for the provision of space heating and the heating of domestic hot water whilst the non-boiler version is intended for the provision of space heating only.

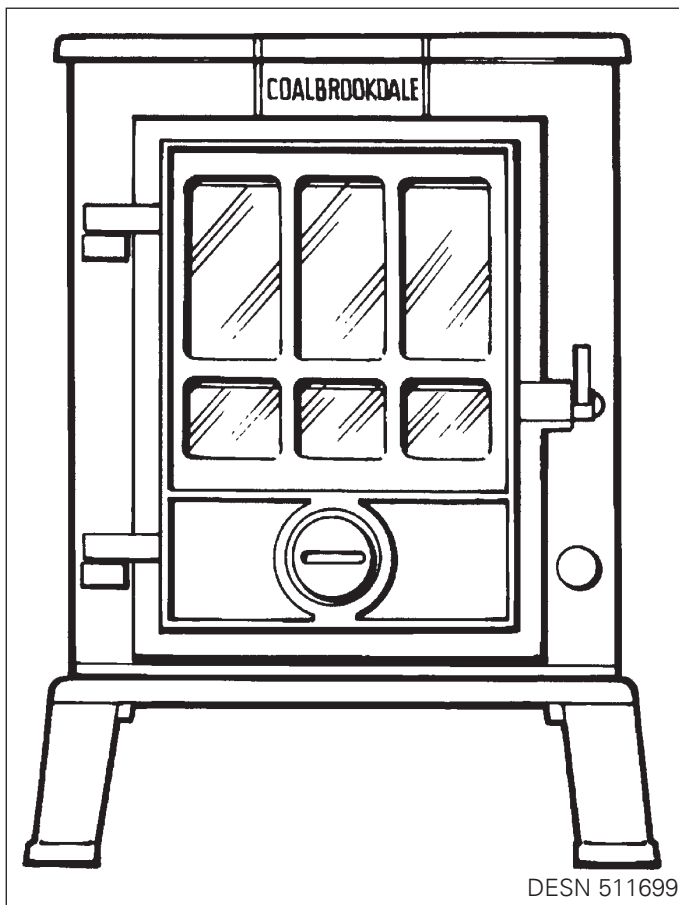

WARNING BOILER MODEL

UNDER NO CIRCUMSTANCES MUST THE
APPLIANCE BE FIRED DRY AS DAMAGE
WILL OCCUR

RECOMMENDED FUELS

Smokeless - Ancit, Centurion, Coalite (Nuts),
Maxibrite, Phurnacite, Sunbrite
(Doubles), Extracite, Supacite,
Blazebrite, Anthracite (Large Nuts),
Welsh Dry Steam Coal (Large Nuts)

PETROLEUM COKE MUST NOT BE USED.

In addition to smokeless fuels the following fuels may be used but only outside smoke control areas:

Selected bituminous housecoal (trebles/large nuts or double nuts) wood logs and peat blocks.

NOTE: MOST TYPES OF LOGS AND PEAT BLOCKS MAY BE USED PROVIDING THEY HAVE BEEN DRIED AND ARE WELL SEASONED. IDEALLY SOFT WOODS SHOULD BE BURNED IN THE DAYTIME AND HARD WOOD OVERNIGHT.

WARNING: WET WOOD SHOULD NOT BE USED AS CREOSOTE AND TAR-LIKE DEPOSITS FROM THE WOOD ARE INCREASED TO A LEVEL WHICH CAN GIVE RISE TO ADVERSE OPERATING CONDITIONS. FUELS SHOULD BE STORED UNDER COVER. BRING LOGS INDOORS FOR A FEW WEEKS BEFORE USE TO BECOME HOUSE DRY.

NOTE: REFER PROBLEMS ABOUT FUEL SUITABILITY OR QUALITY TO FUEL SUPPLIER.

NOTE: IT IS MOST IMPORTANT THAT THE FUELS SHOULD BE OF THE CORRECT SIZE OTHERWISE THE APPLIANCE WILL NOT GIVE A SATISFACTORY PERFORMANCE.

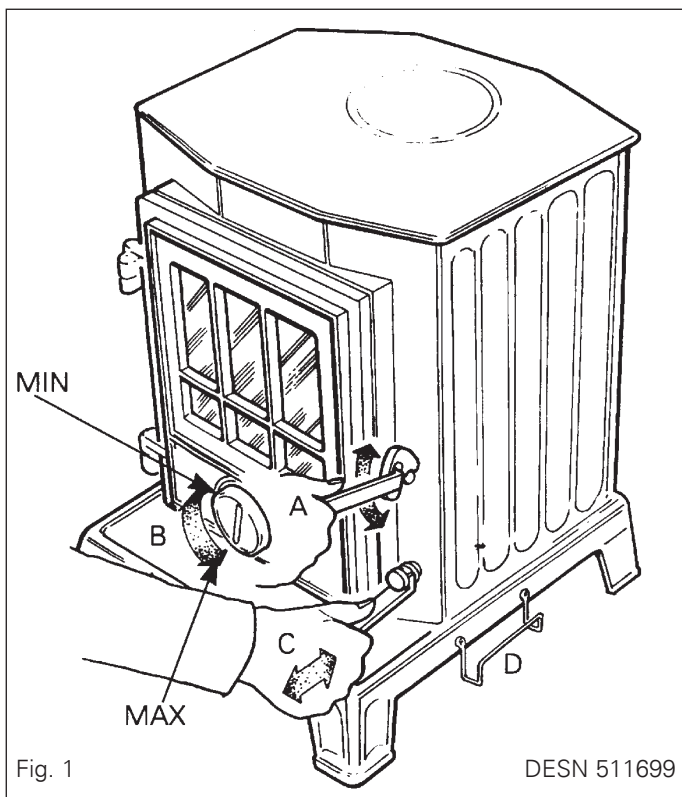

TO LIGHT THE FIRE

Solid Fuel

- Open the door (Fig. 1 'A')
- Lay a liberal supply of wood/paper on the grate together with a small quantity of fuel and light the paper. Alternatively, place two firelighters equal - spaced across grate, cover with fuel and light.
- When blazing, close the firedoor (Fig. 1 'A'), and set firedoor spinwheel to maximum (Fig. 1 'B').
- With the fire established open the firedoor, fill firebox up to the top of the front firebar and sloping upwards to the back.
- Close and lock the firedoor (Fig. 1 'A') with the operating tool.
- Adjust the spinwheel (Fig. 1 'B') to give the desired rate of burning.
- Replace the operating tool on its baseplate support when not in use (Fig. 1 'D').

Bituminous Fuel

If Bituminous fuel is to be burned the following procedure **MUST** be adhered to:-

- Fuel must be refuelled to the maximum limit i.e. at 30° incline from the front edge of the top firebar.
- The door must be left slightly ajar until the top of the fuelbed has flames passing through it.
- The appliance door should then be closed and locked.

WARNING: IF THE DOOR IS CLOSED TOO EARLY, THEN PUFF-BACK CAN BE EXPERIENCED. THESE ARE SMALL EXPLOSIONS WHERE SMOKE COULD BE FORCED THROUGH THE DOOR SEAL OR AIR INLET INTO THE ROOM.

THE APPLIANCE MUST NOT BE LEFT UNATTENDED OR OPERATED WITH THE DOOR OPEN AS THIS COULD CAUSE PHYSICAL DAMAGE TO THE APPLIANCE. THE DOOR SHOULD ONLY BE OPENED FOR RELIGHTING AND REFUELLING.

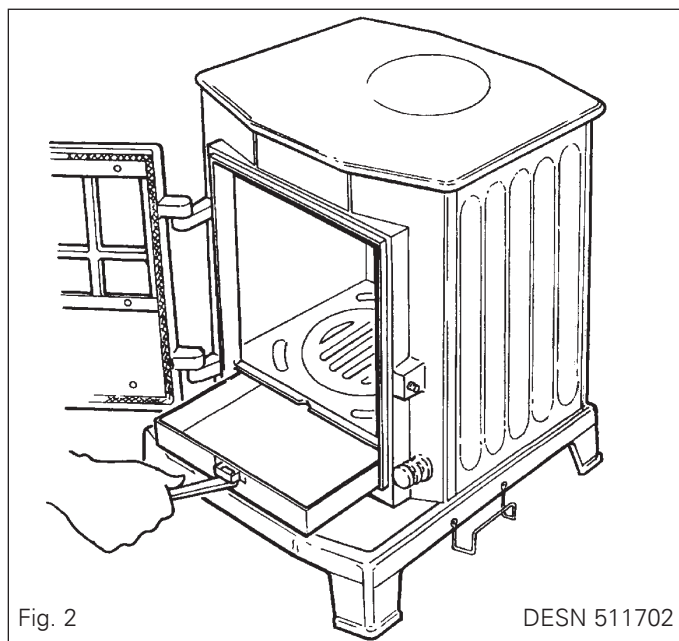

TO REGULATE BURNING

Maximum burning rate is obtained with the spinwheel air control (Fig. 1 'B') operated wide.

Avoid clinker formation which indicates overfiring and always check that the firedoor is closed.

Overnight Banking and Daytime Slow Burning

De-ash thoroughly before re-fuelling and ensure there is a sufficient amount of hot fuel in the firebed before loading. Fuel fire up to the top of the front firebar sloping the firebed upwards to the back of the firebox and temporarily set spinwheel air control to maximum.

Close or nearly close the spinwheel air control (Fig. 1 'B'). Experience will indicate the setting that provides the best results with the individual fuel being burnt.

NOTE DIFFICULTY IN OBTAINING BANKING CAN SOMETIMES BE OVERCOME BY THE USE OF SMALLER SIZE FUEL e.g SUNBRITE SINGLES.

De-Ashing and Ash Removal

- Riddle the bottomgrate by engaging the operating tool on the riddling knob (Fig. 1 'C') and push/pull it sharply for about 10 strokes by which time the fire should be free of ash.
Riddle the grate at least twice daily (more often if required) and always before re-fuelling.
- Open the locked firedoor with the operating tool (Fig. 1 'A').
- Remove the ashpan with the operating tool (Fig.2).

NOTE EMPTY THE ASHPAN AT REGULAR INTERVALS AND DO NOT ALLOW ASH TO ACCUMULATE IN THE ASHPAN UNTIL IT TOUCHES THE UNDERSIDE OF THE BOTTOMGRATE OTHERWISE IT WILL VERY SOON DESTROY THE BOTTOMGRATE.

The continued presence of shale, stone or clinker in the firebed will reduce burning rates.

To remove shale or stone from the firebed, open the firedoors and rake the fire upwards with a poker to bring the shale or stone to the top and remove with tongs. The type of fuel and the air control spinwheel setting, govern the frequency of fuelling.

TO BURN WOOD

When burning wood or peat fuel only, the bottomgrate frame, bottomgrate, riddling tool, firebricks and ashpan can be removed to allow wood, logs or peat to be burnt directly on the baseplate to increase the fire box capacity.

NOTE: BLANK RIDDLING HOLE IN FRONT PLATE WITH BOLT AND NUT PROVIDED (See Fig. 2A)

TO LIGHT THE FIRE

Woodburning

- a. Open the firedoor (Fig. 1 'A').
- b. Before starting the fire, place a 1/2" layer of sand, or wood ash on the bottom of the stove.
- c. Lay a liberal amount of paper and small pieces of wood with two smaller logs placed loosely on top and light.
- d. When blazing,⁴
close the firedoor (Fig. 1 'A'), and set firedoor spinwheel to maximum (Fig.1 'B').
- e. With fire established, open the firedoor, fill firebox up to the top of the front firebar, and sloping upwards to back.
- f. Close and lock the firedoor (Fig. 1 'A') with the operating tool.
- g. Adjust the spinwheel (Fig. 1 'B') to give the desired rate of burning.
- h. Replace the operating tool on its baseplate support when not in use (Fig. 1 'D').

TO REGULATE BURNING

Maximum burning rate is obtained with the spinwheel air control (Fig. 1 'B') open wide.

Overnight Banking and Daytime Slow Burning

Fuel fire up to the top of the front firebar sloping the firebed upwards to the back of the firebox and temporarily set spinwheel air control to maximum.

Close or nearly close the spinwheel air control (Fig. 1 'B'). Experience will indicate the setting that provides the best results with the fuel being burnt.

Wood Ash

To obtain satisfactory results it is preferable to leave a bed of wood ash on the base at all times when the stove is being used. This allow for uniform burning through the fuel and allows for maximum heat absorption from the residual ash.

WARNING: SOLID FUEL MUST NOT BE USED WHEN STOVE IS SET FOR WOOD BURNING ONLY I.E. DO NOT MIX FUEL TYPES.

To revert stove back to solid fuels replace riddling rod, bottomgrate frame, bottomgrate, firebricks and ashpan.

TO REVERT STOVE BACK TO BURN SOLID FUELS

- a. Remove nut and bolt from riddling rod in front plate and front firebar (See Fig. 2A).
- b. **NON-BOILER MODEL**
Ensure the throat plate is correctly located inside the stove and is supported on the three internal supporting lugs (Fig. 3).
BOILER MODEL
Ensure the flue baffle is correctly located (Fig. 4).
- c. The bottomgrate frame sits on support lugs with straight edge forward (Fig. 5).
- d. Locate the bottomgrate to the bottomgrate frame (Fig.5).
- e. Insert the riddling rod through the hole in front plate and engage with bottomgrate (Fig.6).
- f. **NON-BOILER MODEL ONLY**
Place the rear firebrick into the back of the stove on top of the bottomgrate and snugly under the throat plate (Fig. 7).

The lettering 'Back' on the firebrick should be facing the wall of the stove.

NOTE: BACK BRICKS ARE NOT FITTED TO THE BOILER MODELS.

- g. **NON-BOILER MODEL**
Place the left hand firebrick into the stove so that it fits securely behind the holding lugs on the bottomgrate and throat plate. The lettering 'L.H.' should be facing the wall of the stove (Fig. 8).

Raise the throat plate slightly to slip the side bricks behind the holding lugs (Fig. 3).

Repeat procedure for the right hand firebrick.

BOILER MODEL

Place the left hand firebrick into the stove so that it fits securely behind the holding lugs on the bottomgrate and boiler (Fig.4). The lettering 'L.H.' should be facing the wall of the stove (Fig.8).

Repeat the procedure for the right hand firebrick.

- h. Slide the front firebar down onto the bottom grate with the flat edge on the bottom and the taper on the top pointing back down into stove (Fig. 9).
- j. Insert the ashpan (Fig. 2).

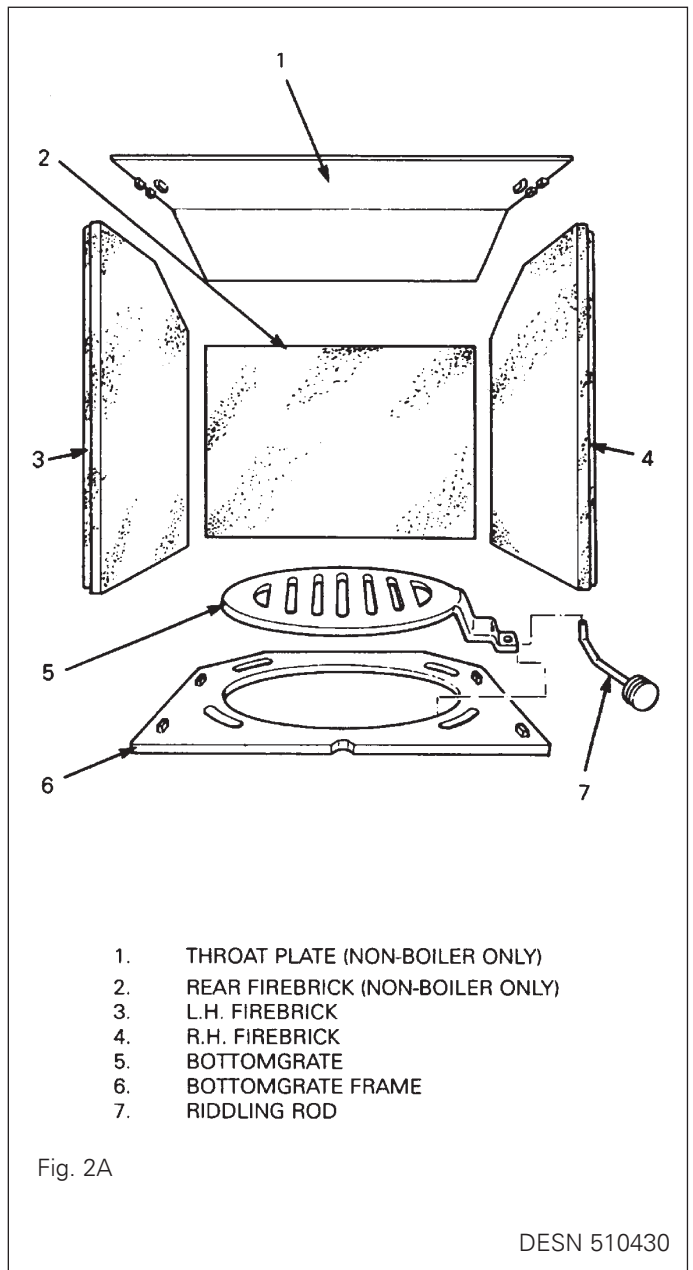

Fig. 2A

DESN 510430

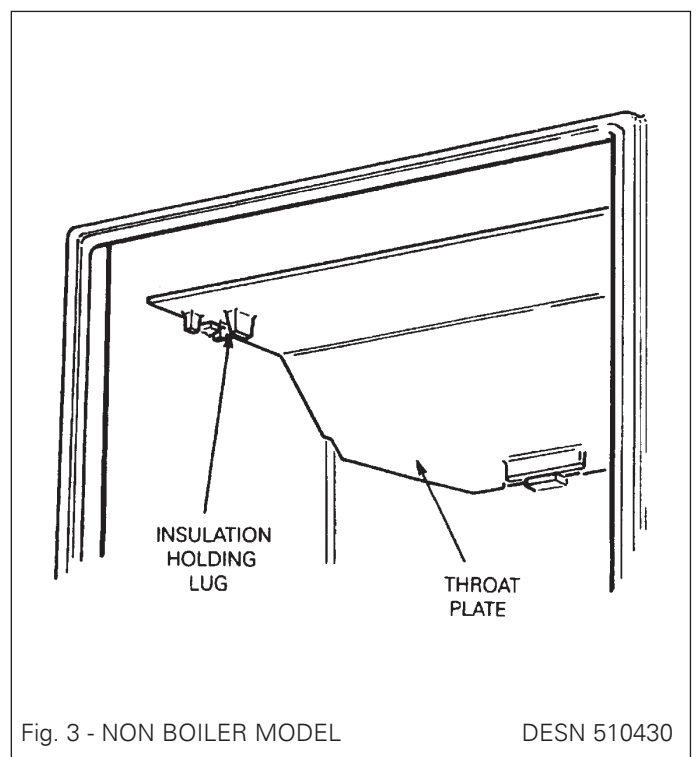
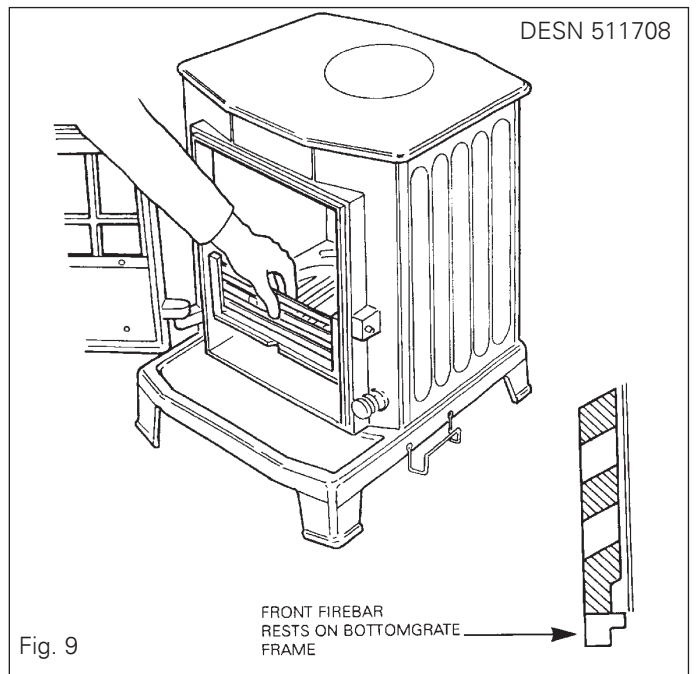
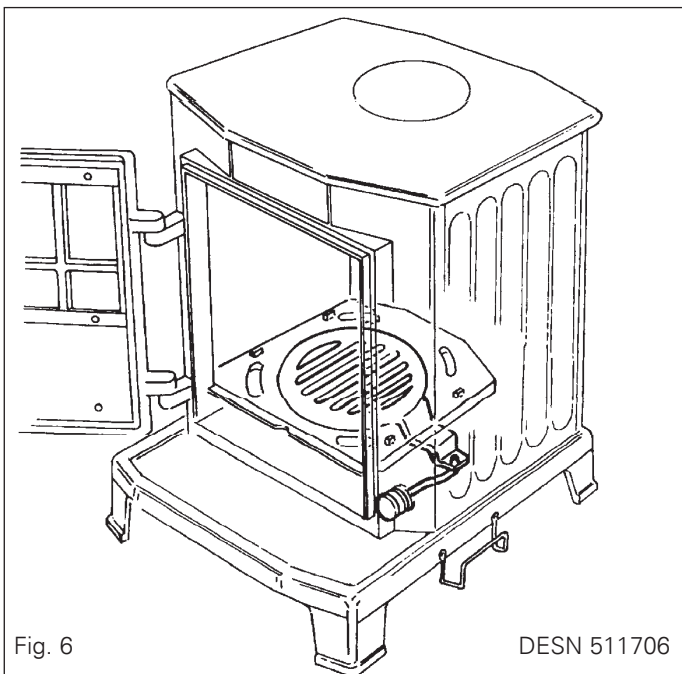
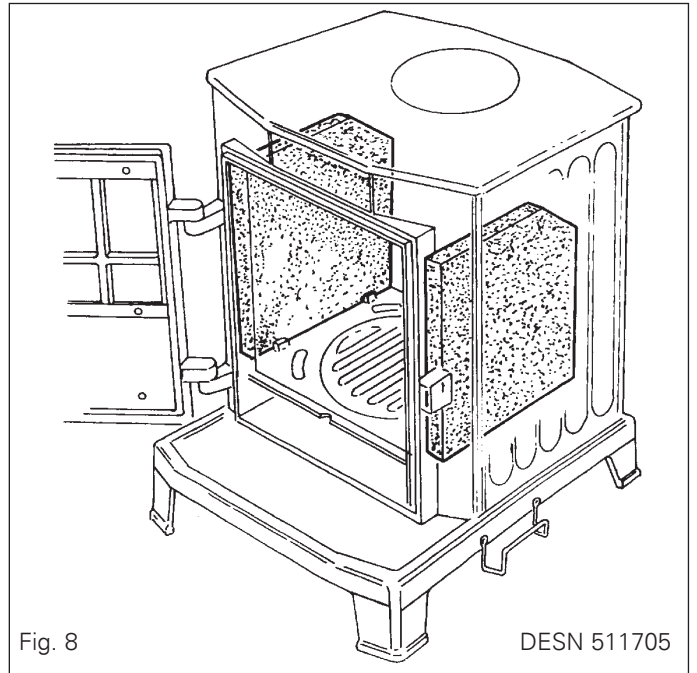
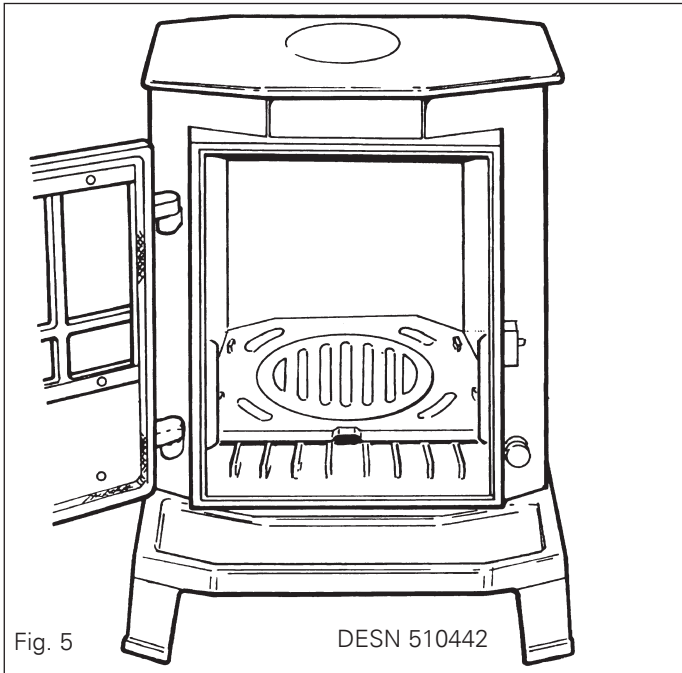
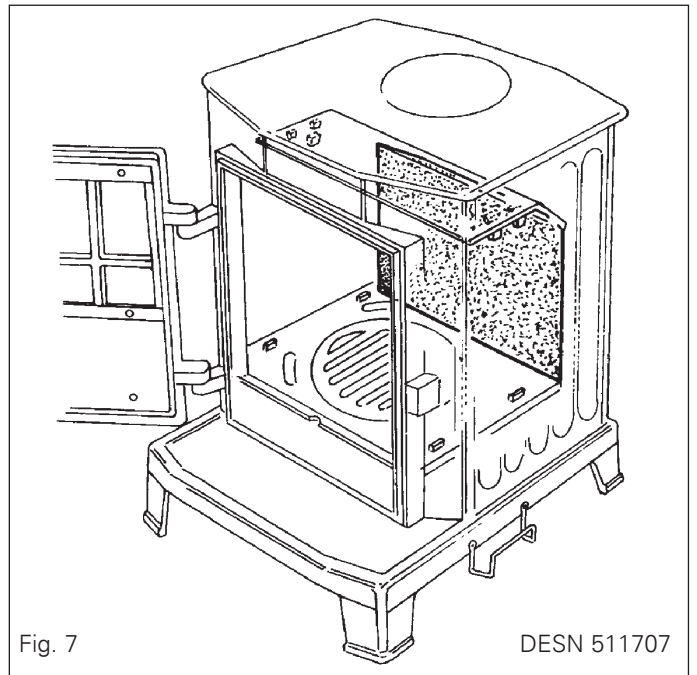
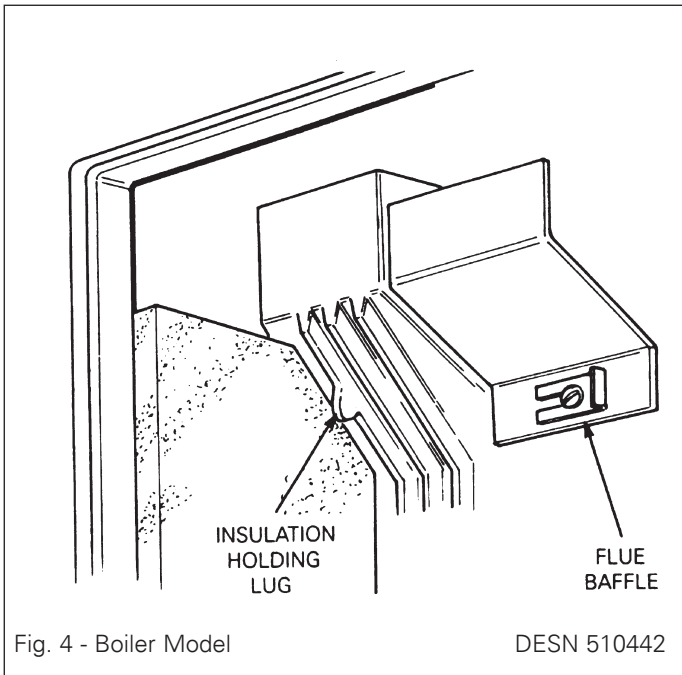

Fig. 3 - NON BOILER MODEL

DESN 510430



FUME EMISSION

WARNING: PROPERLY INSTALLED AND OPERATED THIS APPLIANCE WILL NOT EMIT FUMES.

OCCASIONAL FUMES FROM DE-ASHING AND REFUELLING MAY OCCUR, PERSISTENT FUME EMISSION MUST NOT BE TOLERATED.

IF FUME EMISSION DOES PERSIST, THE FOLLOWING IMMEDIATE ACTIONS SHOULD BE TAKEN.

- a. **OPEN DOORS AND WINDOWS TO VENTILATE ROOM.**
- b. **LET THE FIRE OUT OR EJECT AND SAFELY DISPOSE OF FUEL FROM APPLIANCE.**
- c. **CHECK FOR FLUE OR CHIMNEY BLOCKAGE AND CLEAN IF REQUIRED.**
- d. **DO NOT ATTEMPT TO RE-LIGHT THE FIRE UNTIL CAUSE OF FUME HAS BEEN IDENTIFIED, IF NECESSARY SEEK PROFESSIONAL ADVICE.**

APPLIANCE CLEANING

The top of the throat plate and the flue pipe outlet should be swept on a monthly basis to prevent restricting the flueway, otherwise this may result in fume emission and reducing burning rates.

Boiler Model

- a. Open the firedoor, remove the front firebar.
- b. To remove throat plate, remove deposits from around securing clip then using a light hammer, knock clip from the support pin.
The flue baffle can be removed by hand (Fig.10).
Insert flexible brush into rear or top flue outlet and brush deposits towards firebox (Fig.11).
Reverse procedure to replace throat plate.

Non-Boiler Model

- a. Open firedoor and remove front firebar.
- b. Remove firebricks and throat plate.
- c. Insert flexible brush into rear or top flue outlet brush deposits towards firebox (Fig.12).
- d. Replace throat plate, firebricks and front firebar (Figs. 3, 7, 8 and 9).

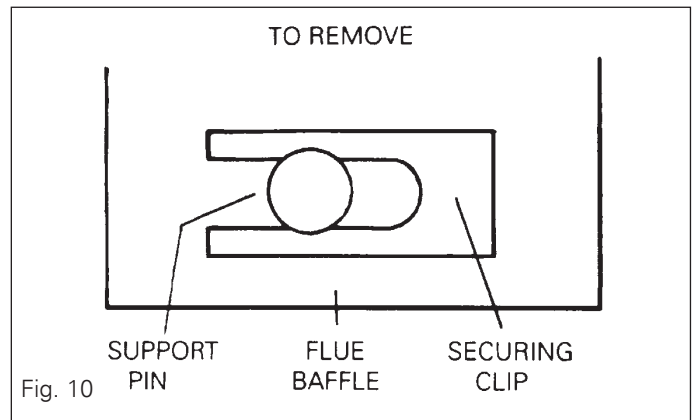

Fig. 10

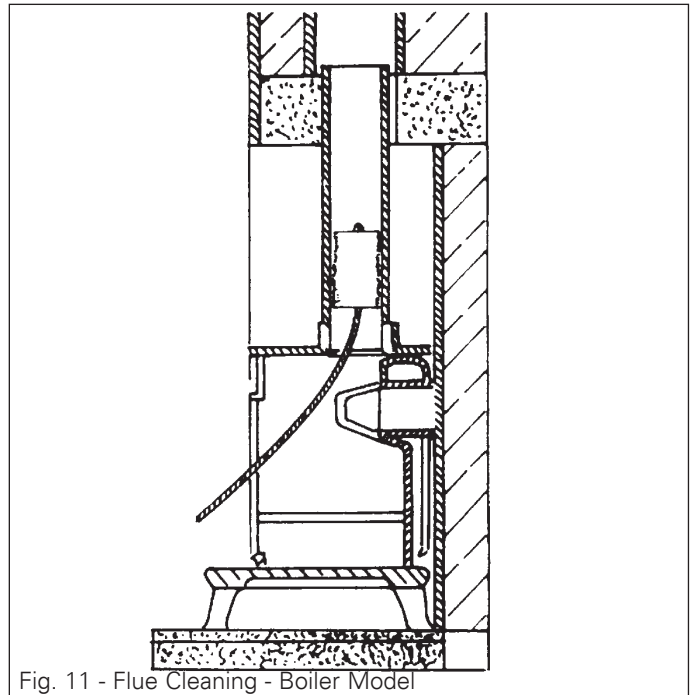

Fig. 11 - Flue Cleaning - Boiler Model

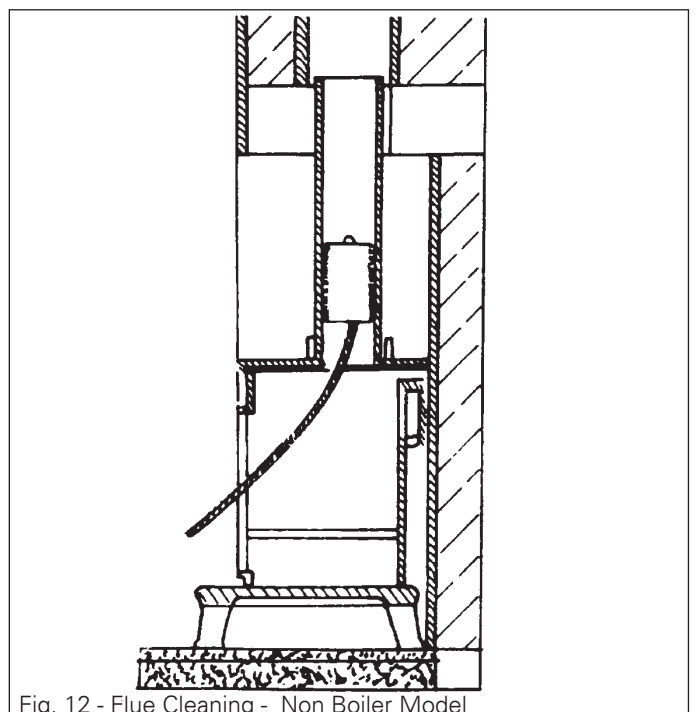

Fig. 12 - Flue Cleaning - Non Boiler Model

CHIMNEY SWEEPING

CHIMNEY SWEEPING: SWEEP AT LEAST ONCE ANNUALLY (See Figs. 11 and 12).

WARNING NEGLECT OF CHIMNEY SWEEPING CAN LEAD TO DANGEROUS FUME EMISSION.

PROLONGED SOOT FORMATION MAY RESULT IN THE FLUEWAY BECOMING BLOCKED AND COULD GIVE RISE TO THE RELEASE OF CARBON MONOXIDE, A POISONOUS GAS, INTO THE ROOM.

Top Flue Only

The Chimney can only be swept through the appliance front.

Back Flue Only against chimney

The chimney must be swept through the soot door above the appliance and the soot removed through the appliance.

Back Flue Only in recess

The chimney is swept through the flue elbow cleaning door and the soot can be removed through the appliance.

- Open the firedoor and remove the front firebar.
- Lift out firebricks and throat plate.
- Insert the chimney sweeping brush into the main flue via soot cleaning door entry or through the flue pipe where possible. Ensure the deposits are separately collected or fall into the firebox for removal. Replace the removed components using the reverse procedure of removal. Sweep flue pipe with flexible brush as described under **'Appliance Cleaning'**.

CLEANING

Use a damp sponge or a proprietary brand of stove cleaner to clean exterior of stove.

WARNING: DO NOT CLEAN THE STOVE WHEN HOT.

With use, the inside face of the glass door may become coated with dust and deposits. To clean the glass, allow it to cool and then wipe with a damp cloth and polish with a dry one.

SERVICING

- Always use a qualified engineer when service is required.
- An inspection of firedoor seal should be made every heating season and replaced if necessary.

PRECAUTIONS

When not in use remove all the fuel and ashes from the firebox. Leave the air control spinwheel open to allow a constant stream of air to pass through the stove.

Replace a circular bottomgrate as necessary to ensure efficient burning.

BOILER MODEL

If the fire is not used when there is a danger of frost the whole system should be drained.

WARNING: NEVER LIGHT THE FIRE IF THE WATER SYSTEM IS SUSPECTED OF BEING FROZEN.

FIREGUARD

Use a fireguard in the presence of children, old and/or infirm people. The fireguard should be manufactured in accordance with BS. 6539.

Replacement parts if required are available through your local stockist.

SPARES LIST

Boiler Model

Part No.	Description	No. Req.
HS5M405042	Front Firebar	1
HS5B3-18259	Bottomgrate	1
HS5M1-18265	Bottomgrate Frame	1
HS1M 90290	Ashpan	1
HS4FLW 500LH-BM	L.H. Side Firebrick	1
HS4FLW 500RH-BM	R.H. Side Firebrick	1

Non-Boiler Model

Part No.	Description	No. Req.
HS5M405042	Front Firebar	1
HS5B3-18259	Bottomgrate	1
HS5M1-18265	Bottomgrate Frame	1
HS1M 90290	Ashpan	1
HS4FLW 500LH	L.H. Side Firebrick	1
HS4FLW 500RH	R.H. Side Firebrick	1
HS4FLW 500B	Rear Firebrick	1
HS4M405048	Firedoor Glass Panel	1
HS5M410039	Throat Plate	1

**For further advice or information contact
your local distributor/stockist**

With Aga-Rayburn's policy of continuous product improvement, the Company reserves the right to change specifications and make modifications to the appliance described and illustrated at any time.



Manufactured By
Aga-Rayburn
Station Road
Ketley Telford
Shropshire TF1 5AQ
England

www.aga-rayburn.co.uk
www.agacookshop.co.uk
www.agalinks.com