

WARNING

This information is a copy of an original archive, therefore Aga cannot be held responsible for its continued accuracy.

Consumer Protection Act 1987

As manufacturers and suppliers of cooking and heating products, in compliance with Section 10 of the Consumer Protection Act 1987, we take every care to ensure, as far as is reasonably practicable, that these products are so designed and constructed as to meet the general safety requirement when properly used and installed. To this end, our products are thoroughly tested and examined before despatch.

IMPORTANT NOTICE: Any alteration that is not approved by Aga-Rayburn, could invalidate the approval of the appliance, operation of the warranty and could also affect your statutory rights.

Control of Substances - Health & Safety Important

This appliance may contain some of the materials that are indicated below. It is the Users/Installers responsibility to ensure that the necessary personal protective clothing is worn when

handling where applicable, the pertinent parts that contain any of the listed materials that could be interpreted as being injurious to health and safety, see below for information.

Firebricks, Fuel beds, Artificial Fuels - when handling use disposable gloves.

Fire Cement - when handling use disposable gloves.

Glues and Sealants - exercise caution - if these are still in liquid form use face mask and disposable gloves.

Glass Yarn, Mineral Wool, Insulation Pads, Ceramic Fibre, Kerosene Oil - may be harmful if inhaled, may be irritating to skin, eyes, nose and throat. When handling avoid inhaling and contact with skin or eyes. Use disposable gloves, face-masks and eye protection. After handling wash hands and other exposed parts. When disposing of the product, reduce dust with water spray, ensure that parts are securely wrapped.

Non-Boiler Model:

Fig. 1 The appliance can be installed as a back outlet flue only.

Boiler Model:

Fig. 2 There are two sets of back outlet 'flow and return' connections on the L.H. or R.H. side of the boiler. The stove can be installed as a back outlet flue only.

WARNING
BOILER MODEL
UNDER NO CIRCUMSTANCES MUST
THE APPLIANCE BE FIRED DRY AS
DAMAGE WILL OCCUR

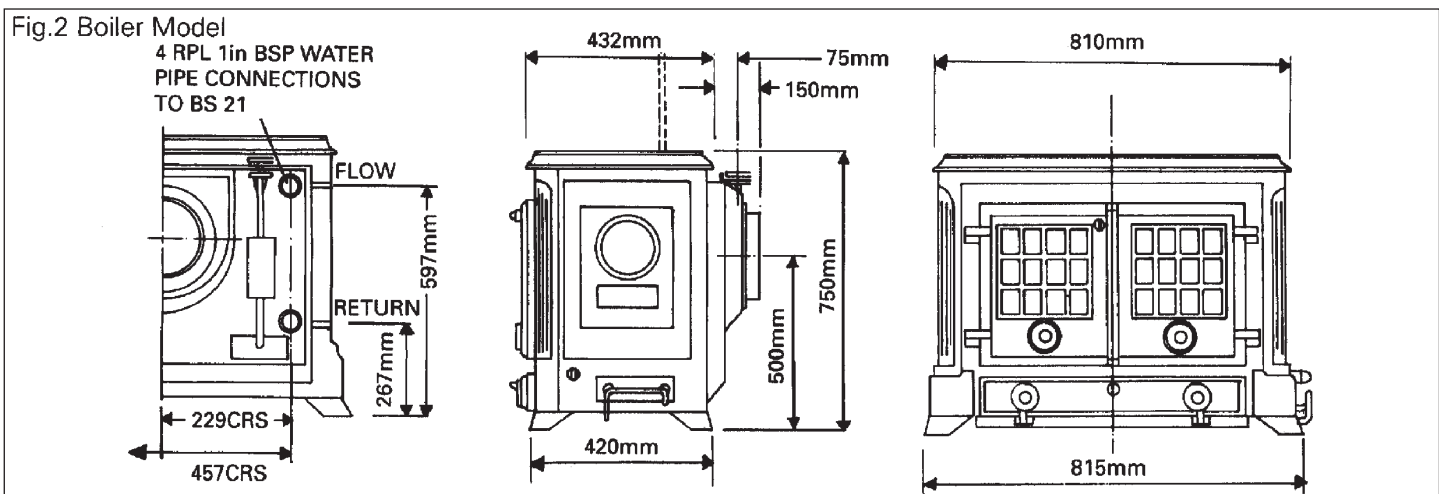
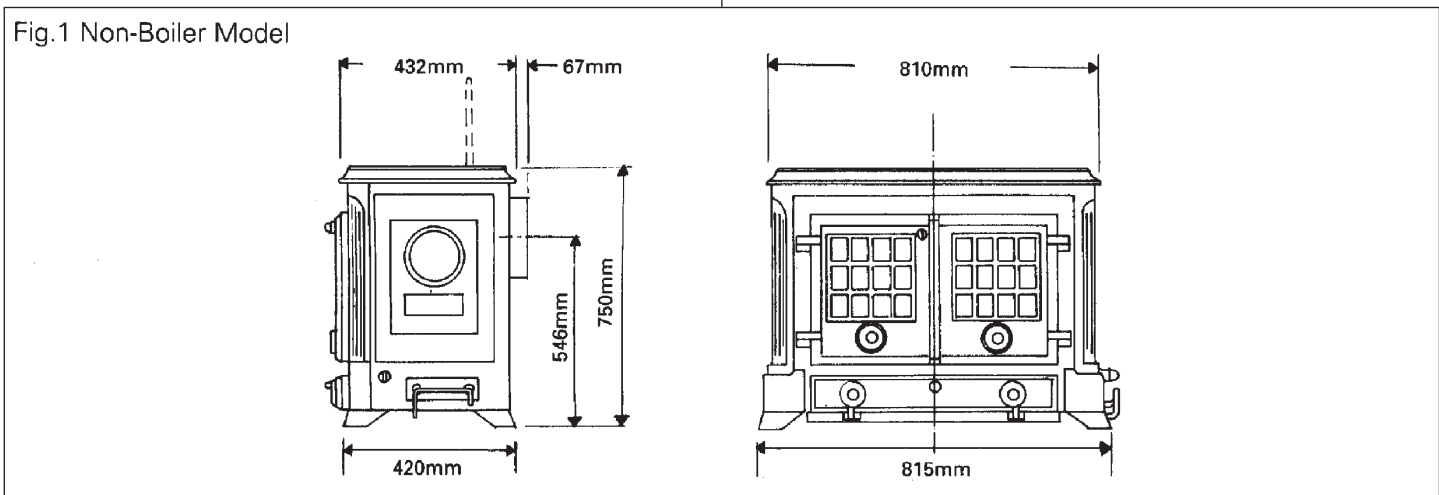

PERFORMANCE

The Darby Stove with Boiler is intended to provide space heating and the heating of domestic hot water and radiators whilst the non-boiler model provides space heating only.

RATING

Non-Boiler Model	Rating		Room Size	
	Direct Space Heating	kW Btu/h	16.1 55,000	m ³ ft ³
Boiler Model	Smokeless Fuel		Coal	Wood
Direct Space Heating	kW Btu/h	8.2 28,000	8.8 30,000	7.2 25,000
Water Heating	kW Btu/h	12.3 42,000	11.7 40,000	8.8 30,000
The maximum room size (of normal construction) and radiator surface that can be heated are:				
Direct Space Heating	m ³ ft ³	159 *5,600	170 *6,000	141 *5,000
Pipe and Radiator Surface	m ³ ft ³	24.4 262.5	23.2 250.0	17.4 187.5
Radiator Surface	m ³ ft ³	22.0 237.5	20.9 225.0	12.3 132.5

The recommended heating surface area is based on an average heat emission of 0.5 kW/m² (160 Btu/h/ft²). These figures are maxima and must not be exceeded. A margin (about 10% or 1.4m² - 15ft²) is recommended.
NOTE: FIGURES MARKED * ARE MAXIMUM WITH WATER LOAD AT FULL OUTPUT.

HOT WATER SYSTEM

1. A 140 litre (30 gallon) capacity indirect hot water storage cylinder of the double feed pipe, complying with BS 1566 Part 1: DF Type 8 should be lagged and fixed vertically as near as possible to the stove.
The 28mm minimum diameter primary flow and return pipes must not exceed 10m in length and pipes longer than 5m must be lagged.
Ensure that the flow pipes rise continuously from the stove boiler to the cylinder to ensure good gravity circulation. In combined systems, the water draw-off pipes to the taps must be dead leg connections from the vent/expansion pipe.
2. One boiler flow connection (preferably that to the cylinder), must have an open vent. The connection to the boiler must be such that air cannot be trapped in the boiler. Any pipe size reduction must be made on the vertical pipe of the vented flow pipe.
The heating flow and return pipes may be 22mm and should preferably be connected to opposite tappings to each other on each side of the boiler.
3. All installations must be fitted with a drain tap at the lowest point of the system.

4. It is recommended that a gravity heat leak radiator 0.9 - 1.4m² (10-15ft²) heating surface be included, or a reverse acting cylinder thermostat to activate the pump in the event of overheating.
5. **NOTE:** IF THERE IS A POSSIBILITY OF BOILING TAKING PLACE A REVERSE ACTING THERMOSTAT (SUCH AS THE SATCHWELL TYPE 5A) SHOULD BE FITTED TO THE CYLINDER OR PRIMARY FLOW PIPE AND ELECTRICALLY CONNECTED TO THE CENTRAL HEATING WATER CIRCULATOR, THIS WILL SWITCH ON THE WATER CIRCULATOR TO PREVENT BOILING.
6. **Boiler - Recommendation**
Water circulators which are continually operative will in conjunction with prolonged burning under banked conditions create cool boiler surfaces within the firebox. This in turn will encourage boiler surface condensation followed by surface condensation and reduced life span of the boiler. To minimise this incident we strongly recommend a water pipe clamp on thermostat e.g. EBERLE Type 8750 or SATCHWELL SUNVIC Type PA fitted to the Heating Return pipe sited close to the appliance. The thermostat should be electrically connected to the water circulator as indicated on the 'Typical Wiring Diagram' Fig. 3 and the adjustable dial should be set at a temperature of 50°C (122°F). A fall in the return pipe water temperature below 50°C interrupts the power to the water circulator which will then not operate until the temperature exceeds 50°C and power is restored.

Fig.3 Typical Wiring Diagram

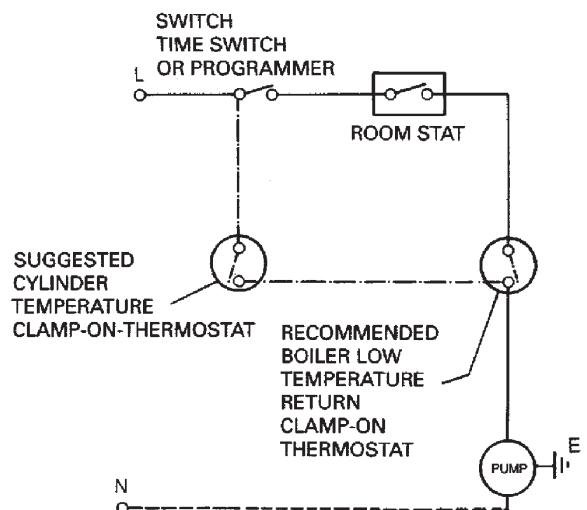

THE CHIMNEY

For correct operation of the appliance, the height of the chimney from its base should not be less than 5.5m and terminate above the roof in accordance with current Building Regulations and requirements as outlined in BS 6461 Part 1 and BS 7566 Parts 1-4 should be observed. The structural flue through the chimney should not be less than 200mm diameter. Pargeted lined flues, 230mm x 230mm must be in sound condition, and any internal offsets should not be less than 60° to the horizontal. Check that the flue exit is not obstructed or reduced in size.

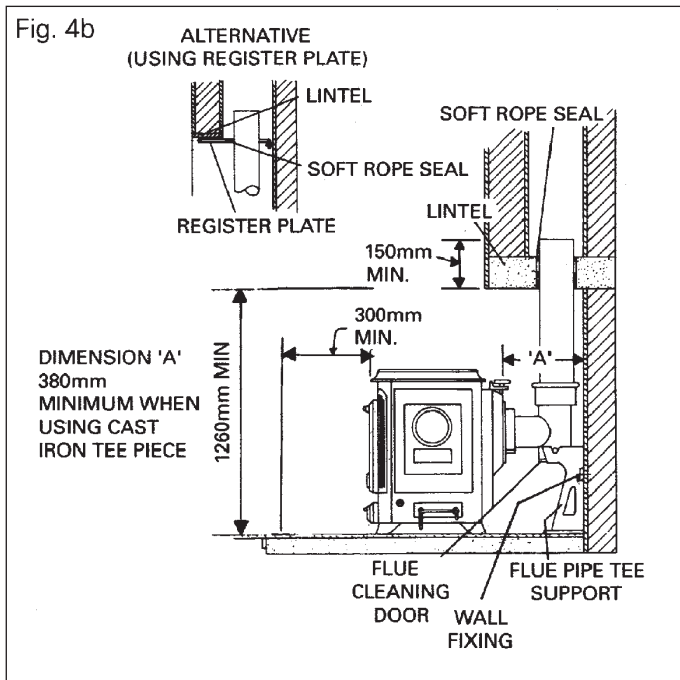
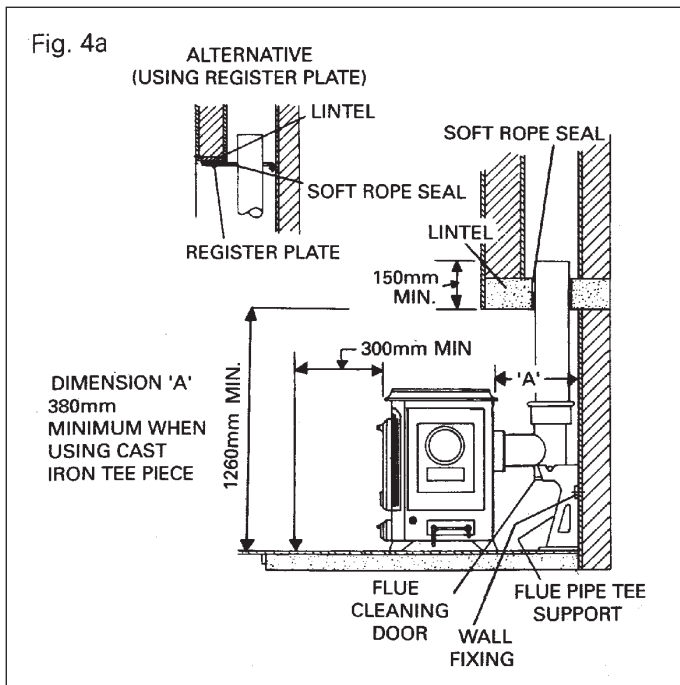

IMPORTANT: FAILURE TO OBSERVE THE RECOMMENDED MINIMUM SIZES OR METHODS OF FLUE CONNECTION MAY LEAD TO FUME EMISSION INTO THE ROOM AND REDUCED BURNING RATES.

Existing Chimney

The internal and external condition of the chimney should be checked **before** the appliance is installed and rectification made where necessary to prevent air leakage or porosity.

The flue through the chimney should be formed with 200mm diameter minimum moisture and acid resistant liners to BS 1181 or precast linings such as specified in the current Building Regulations and requirements in BS 6461 Part 1 and BS 7566 Parts 1-4 should be observed.

When repairing chimneys, it is recommended that the Building Inspector be consulted before the commencement of work with particular attention to the chimney height and its termination.

NOTE: THE CHIMNEY SHOULD BE SWEEPED BEFORE INSTALLATION.

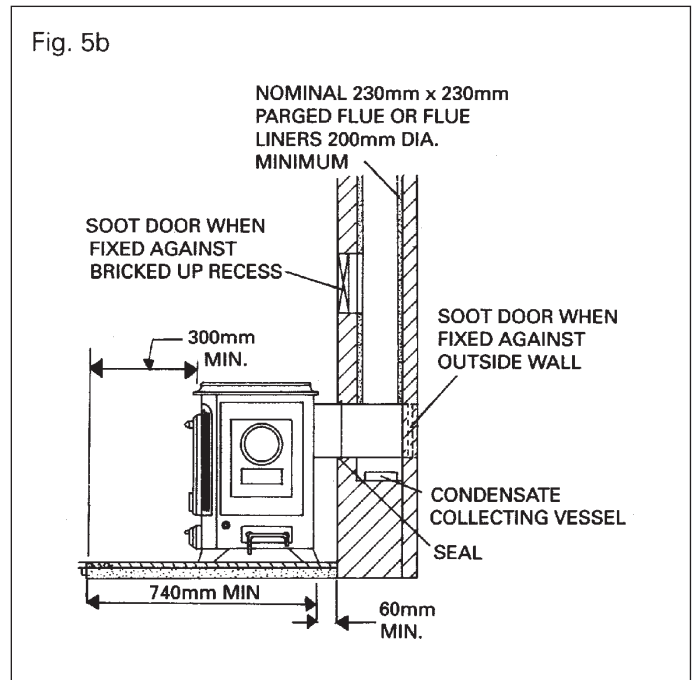
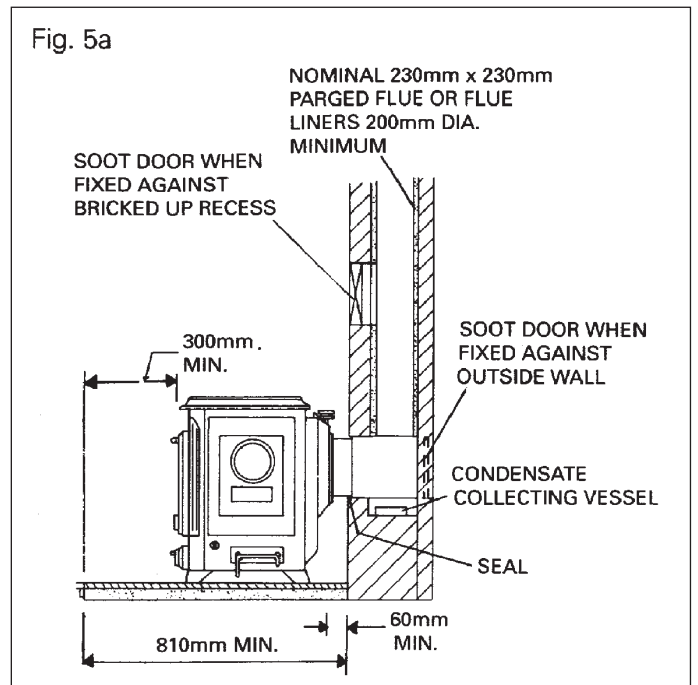

Where the chimney is believed to have served an open fire installation it is possible that the higher flue gas temperature from a closed appliance may loosen deposits that were previously firmly adhered, with the consequent risk of flue blockage. It is therefore recommended that the chimney be swept a second time after one month of regular use.

New Chimney

The flue should not be less than 200mm diameter and its soundness confirmed by smoke testing or contacting HETAS LTD who will give advice on the test method. Ensure the chimney liners are free of any internal projections such as building jointing composition before the appliance is installed.

Factory-Made Insulated Chimney

It is recommended that the internal face of the chimney be refractory lined and otherwise comply with BS 4543.

The recommended minimum diameter is 200mm and chimney manufacturers should be consulted for further advice.

Chimney Terminations

All chimneys should terminate above the roof level in accordance with current Building Regulations and as outlined in BS 6461 Part 1 and BS 7566 Parts 1-4. However well designed, constructed and positioned, the satisfactory performance of a flue can be adversely affected by the downdraughts caused by adjacent tall buildings and trees or even nearby hills. These deflect the wind creating a zone of high pressure over the terminal causing it to blow directly down the chimney flue.

A suitable anti-downdraught terminal such as the **Marcone** will usually effectively combat low pressure down-blow but no known cowl is likely to prevent downdraught due to a high pressure zone.

NOTE: ADVISE THE USER TO ENSURE THE CHIMNEY FLUES ARE THOROUGHLY SWEEPED AT A MINIMUM OF 12 MONTHLY INTERVALS AFTER THE APPLIANCE IS COMMISSIONED.

PREPARATION OF BUILDERS RECESS OPENING

The appliance and recess, hearth and chimney flue installation should be in accordance with the current recommendation of the British Codes of Practice BS 8303, BS 6461 Part 1 and BS 7566 Parts 1-4, with the boiler and heating installation complying with BS 5449 Part 1.

The boiler section must also be installed in accordance with the byelaws of the Local Water Undertaking, Regulations for the Electrical Equipment of Buildings - published by the Institute of Electrical Engineers and any

relevant requirements of the Local Authority.

The appliance can be installed in a non-combustible recess in which the hearth must be level and together with the adjacent walls, conform to the current Building Regulations.

The clearance between the appliance and any combustible material must be maintained as indicated in Figs 4a, 5a, 5b and 6.

AIR SUPPLY

A Permanent unobstructed air vent is required having a minimum effective area of 86cm² and communicating directly to outside air or an adjacent room which itself has a permanent air vent direct to outside air.

Effect of Extractor Fan

Avoid if possible, the installation of an extractor fan in the same room as the appliance or the room where the permanent vent is located. Compensating extra air inlets must be introduced equivalent to the capacity of the fan when fitted.

FLUE LAYOUT

Figs. 4a and 4b show the stove connected to an existing brick chimney with vertical flue pipe connected to the stove with a right angled tee piece. Support brackets are recommended to support weight of flue connecting pipes. The exit end of the flue pipe must extend a minimum of 150mm into the overhanging brickwork. Any cavities or pockets above the register plate should as far as possible, be filled with the flue pipe exit extended into the throat of the chimney.

If a flue liner or insulated chimney is used, the diameter should not be less than 200mm in both cases. Figs 5a and 5b.

Fig. 6

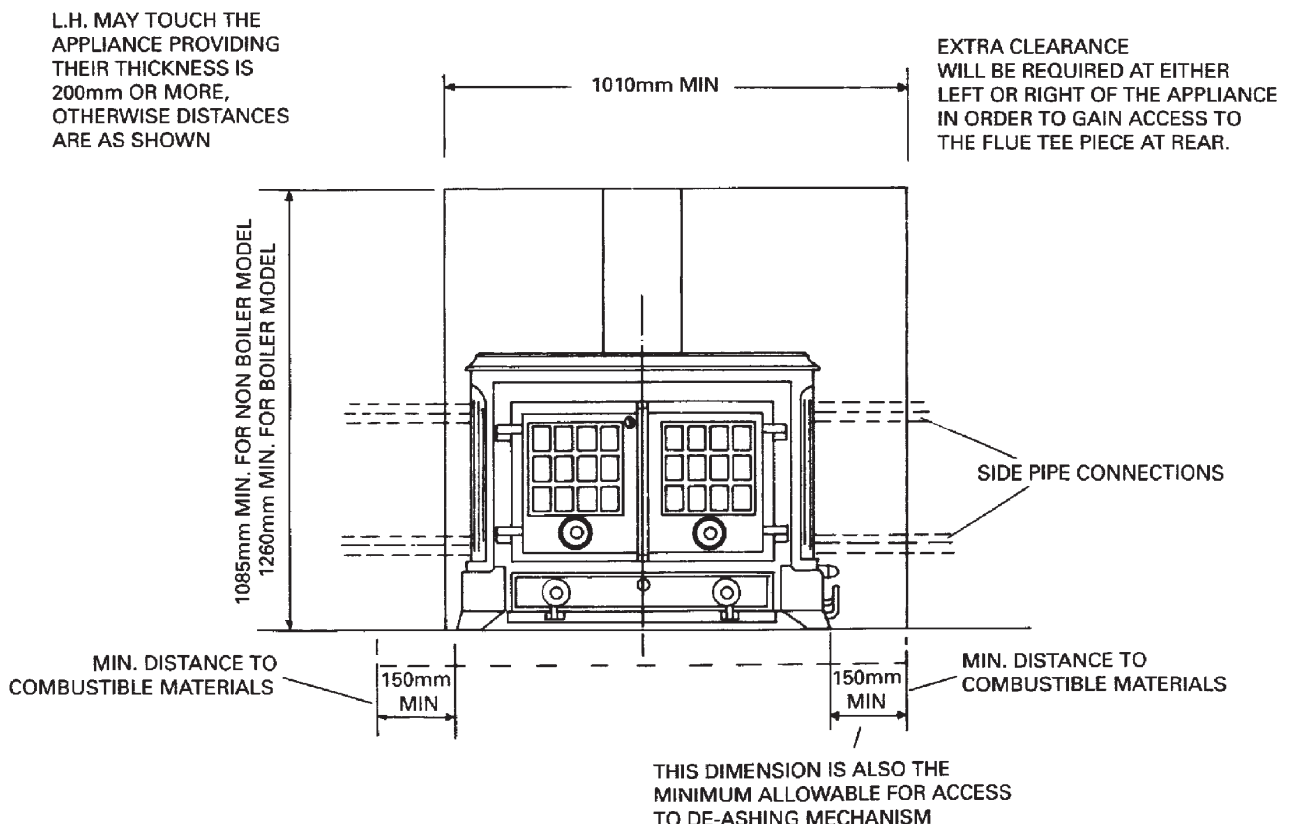

Figs. 5a and 5b show a brick flue outlet into a chimney brickwork.

EXTENDED LENGTHS OF HORIZONTAL PIPEWORK MUST BE AVOIDED AND ARE NOT RECOMMENDED, AND SHALL NOT EXCEED 150mm.

NOTE: WHATEVER METHOD OF INSTALLATION IS UTILISED, AIR MUST NOT BE ALLOWED TO ENTER THE CHIMNEY EXCEPT THROUGH THE STOVE AND ALL JOINTS MUST BE AIRTIGHT. IF THE CHIMNEY IS UNLINED AND THERE IS ANY DOUBT ABOUT ITS CONDITION, IT SHOULD BE LINED IN ACCORDANCE WITH THE CURRENT BUILDING REGULATIONS. PROVISION **MUST** ALWAYS BE MADE FOR SWEEPING THE CHIMNEY.

IMPORTANT: CEMENT PIPES AND FITTINGS MUST NOT BE USED WITHIN 2m OF THE STOVE OUTLET. CHIMNEYS OF PLAIN PIPE ARE NOT RECOMMENDED BUT CERTAIN PROPRIETARY MAKES OF INSULATED CHIMNEY ARE SUITABLE.

INSTALLATION

Handle the firedoor with care to ensure the glass panels remain intact.

The stove is delivered fully assembled but all fire cement joints should be examined for soundness and if necessary, resealed before installation.

After unpacking the stove, remove all packaged parts from inside the stove and inspect the stove to ensure no damage has occurred during delivery.

If there is a problem contact your nearest stockist.

Packaged parts contain a Flue Collar and Operating Tool Support Cradle complete with two screws to secure the Cradle to the bottom R.H. side of the stove.

NOTE: THE FLUE COLLAR SUPPLIED WITH THE STOVE IS SUITABLE FOR USE WITH VITREOUS ENAMEL STEEL PIPE. A SPECIAL FLUE COLLAR IS REQUIRED FOR CONNECTION TO CAST IRON FLUE PIPE OR A CAST IRON TEE PIECE. SPECIAL FLUE COLLARS ARE AVAILABLE THROUGH YOUR LOCAL COALBROOKDALE STOCKISTS.

1. Fix flue connector to rear of stove with screws provided.
2. Position the stove in required position relative to chimney flue and on non-combustible hearth ensuring there is sufficient room allowed:
 - a. On stove R.H. side to enable operation of riddling tool. Fig. 6.
 - b. At rear of L.H. side of stove to give access for replacement of thermostat of high output boiler model. See Fig. 7.
3. Cut length of 200mm diameter pipe to suit chosen method of flue connection. Insert flue pipe spigot in stove outlet socket and caulk joint with soft rope and cement.
4. Connect flue pipe to chimney with selected method. Figs. 4a, 4b 5a and 5b.
5. Make connections to the boiler with provision for draining at the lowest point, fill with water and test. Make good any brickwork around pipes.

6. Check that the bottomgrate reciprocates correctly and that the throat plate is correctly located/sealed.

Boiler Model Only

7. Plug any of the 1in BSP boiler connections not required and fit half unions as required.
8. Check and if necessary re-set thermostat valve plate setting. See Fig. 7.

Fig. 7

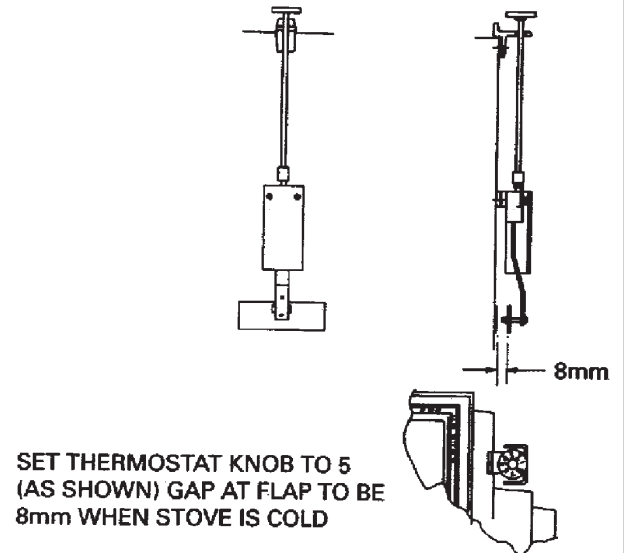

COMMISSIONING

1a. Non-Boiler Model

When lighting open both firedoors and place paper and sticks with a small quantity of fuel onto the bottomgrate. Ignite paper and set both ashpit door spinwheels fully open and lock both firedoors.

1b. Boiler Model

Check that the system is full of water and free from air locks.

When lighting, open both firedoors and place paper and sticks with a small quantity of fuel onto the bottomgrate. Ignite paper and set the thermostat knob to 8 (high) and lock both firedoors.

When established, balance the water system.

With the appliance under fire, check for soundness of seals/joints and that the flue functions correctly in permitting all smoke and fumes to be vented through the chimney.

GENERAL INFORMATION

1. Bottomgrate bars - there are nine grate bars of one type and ten of another. The ten bars occupy the ends and the intermediate positions. The nine bars fit between these.

See that they are properly placed on the cross front firebar and move freely when riddled.

2. If the thermostat has been removed for any reason, refer to the thermostat adjustment or replacement instructions.

Flue Pipe

200mm diameter cast iron flue pipe and fittings in a matt black paint finish are available through your local stockist. Replacement parts if required are available through your local stockist.

Models	Non-boiler	Boiler
Weight of complete stove	241Kg	301 Kg

INSTRUCT USER

After completing the installation, the Heating Contractor should demonstrate to the user, the operation of the fire, e.g. ashpit door spinwheel or thermostat setting, as appropriate, the method of riddling as well as the routine flue cleaning method.

Ensure the installation and operating instructions are left in the possession of the user.

BOILER MODEL

Advise the user that under no circumstances must the appliance be fired dry as damage will occur.

Advise the User of the precautions necessary to prevent damage to the heating system and to the building in the event of the heating system remaining inoperative during frost conditions.

**For further advice or information contact
your local distributor/stockist**

With Aga-Rayburn's policy of continuous product improvement, the Company reserves the right to change specifications and make modifications to the appliance described and illustrated at any time.



Manufactured By
Aga-Rayburn
Station Road
Ketley Telford
Shropshire TF1 5AQ

www.aga-rayburn.co.uk
www.agacookshop.co.uk