

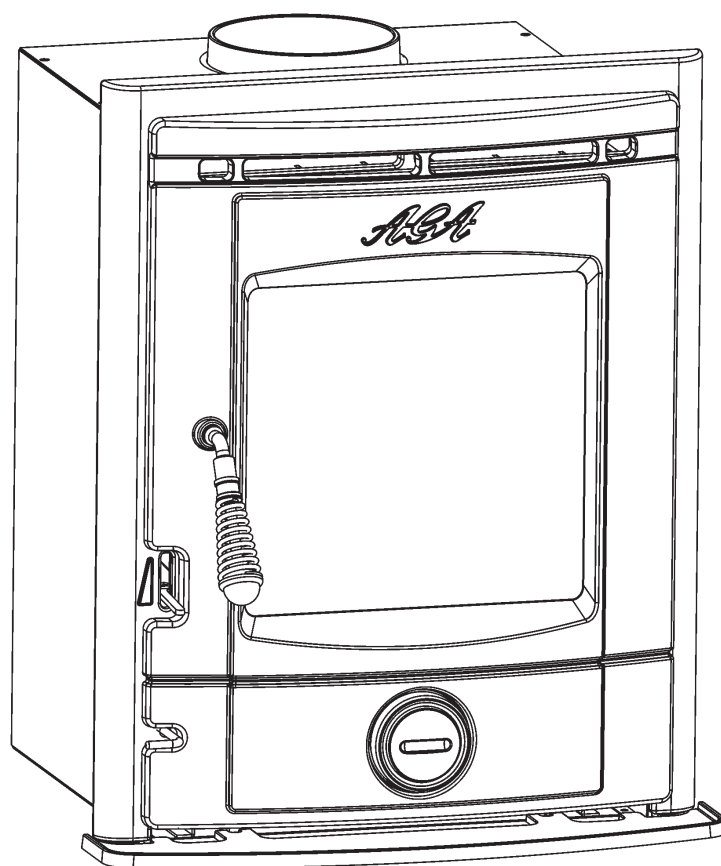

Stretton Insert Stove



This appliance is hot while in operation and retains its heat for a long period of time after use. Children, aged or infirm persons should be supervised at all times and should not be allowed to touch the hot working surfaces while in use or until the appliance has thoroughly cooled.

When using the stove in situations where children, aged and/or infirm persons are present a fireguard must be used to prevent accidental contact with the stove. The fireguard should be manufactured in accordance with BS 6539.

INSTALLATION AND OPERATING INSTRUCTIONS

TABLE OF CONTENTS

PAGE NO.

1.	Insert Stove Installation & Operating Instructions	2
2.	General	2
	Handling	2
	Fire Cement	2
	Asbestos	2
	Metal Parts	2
3.	Pre-Installation Assembly	2
4.	Chimney	2
5.	CO Alarms	3
6.	Fitting Instructions	4
7.	Down Draughts	6
8.	Ventilation & Combustion Air Requirements	7
9.	Commissioning & Handover	7
10.	Location	8
11.	Floor Protection	8
12.	Clearances to Combustibles	8
13.	Stove Dimensions	9
14.	Technical Data	9
15.	Primary air Control Spin Valve	9
16.	Secondary Air Control Slider	9
17.	Recommended Fuels	10
18.	Refuelling	10
19.	Slow Burning	10
20.	De-ashing	10
21.	Maintenance	11
22.	Chimney Cleaning	11
23.	Important Notes	11
24.	Lighting	12
25.	Fire Safety	12
26.	Glass	12
27.	Summer Shutdown	12
28.	Exploded View	13



INSERT STOVE INSTALLATION & OPERATING INSTRUCTIONS

NOTE: Please note that it is a legal requirement under England & Wales Building Regulations that the installation of the stove is either carried out under Local Authority Building Control approval or is installed by a Competent Person registered with a Government approved Competent Persons Scheme. HETAS Ltd operate such a Scheme and a listing of their Registered Competent Persons can be found on their website at www.hetas.co.uk.

GENERAL

When installing, operating and maintaining your stove respect basic standards of fire safety. Read these instructions carefully before commencing the installation. Failure to do so may result in damage to persons or property. Save these instructions for future reference.

Special care must be taken when installing the stove such that the requirements of the Health & Safety at Work Act are met.

Handling

Adequate facilities must be available for loading, unloading and site handling.

Fire Cement

Some types of fire cement are caustic and should not be allowed to come into contact with the skin. In case of contact with the skin wash immediately with plenty of water.

Asbestos

This stove contains no asbestos. If there is a possibility of disturbing any asbestos in the course of installation then please seek guidance and use appropriate protective equipment.

Metal Parts

When installing or servicing this stove care should be taken to avoid the possibility of personal injury.

IMPORTANT WARNING: This stove must not be installed into a chimney that serves any other heating appliance. There must not be an extractor fan fitted in the same room as the stove as this can cause the stove to emit fumes into the room.

The installation must be completed in accordance with current National and European Standards and Local Codes. It should be noted that the requirements and these publications may be superseded during the life of this manual.

PRE-INSTALLATION

After removing the stove from the packaging, open the fire door and remove the loose packing. Prior to installation all the internal components of the stove are removed to gain access to fixings and to make it lighter for installation.

Remove the refractory fire bricks, these bricks are loose and just need to be lifted clear of the grate support plate before they can be removed.

To remove the loose baffle, lift the front edge until it hits the top and then slide it forward. Then drop the rear edge and the baffle will slide down. To remove the fixed baffle, loosen the two screws and slide it forwards, it will then drop down.

To remove the cast iron liners, lift them clear of the grate support plate and then move the front edge of the casting towards the middle of the stove, and clear of the back wall of the stove, then tilt the casting so that it can be removed diagonally through the opening. Remove the flue spigot and gasket by removing the four bolts.

Next, remove the grate by pushing it from underneath, the riddling bar is not fixed to the grate. This will allow access to four M6 fixings which will attach the stove to the outer casing. Remove the 4 fixings, allowing the insert stove to be removed from the external casing.

CHIMNEY

THIS PRODUCT IS SUITABLE FOR CHIMNEY INSTALLATION ONLY.

The stove is a radiant room heater and must be connected to a chimney of the proper size and type. The chimney must have a cross sectional area of at least 124cm² or a diameter of at least 150mm. Never connect to a smaller size chimney. Do not connect to a chimney serving another appliance. Minimum chimney height 4.5 meters from floor on which stove is installed.

It is recommended that a flue liner of diameter 150mm be used to line the chimney, the liner should be approved for use with solid fuel. See Fig. 1.

It is permitted to connect using a closure plate and a connection piece from the stove to the closure plate (See Fig 2), provided that the chimney is of sound construction with no leaks or cracks, a clay flue liner has been used that can withstand up to 1000°C, the clay liner has a diameter no greater than 200mm.

ALL FLUE INSTALLATIONS ARE THE RESPONSIBILITY OF THE INSTALLER.

Any existing chimney must be clear of obstruction and have been swept clean immediately before installation of the stove. If the stove is fitted in place of an open fire then the chimney should be swept one month after installation to clear any soot falls which may have occurred due to the difference in combustion between the stove and the open fire.

For guidance when installing new chimney systems or relining existing chimneys please refer to BS EN 15287:2007

The stove must be connected to a chimney with a minimum continuous draught of 12 Pascal's (.05" WG). Poor draught conditions will result in poor performance.

Fig 1

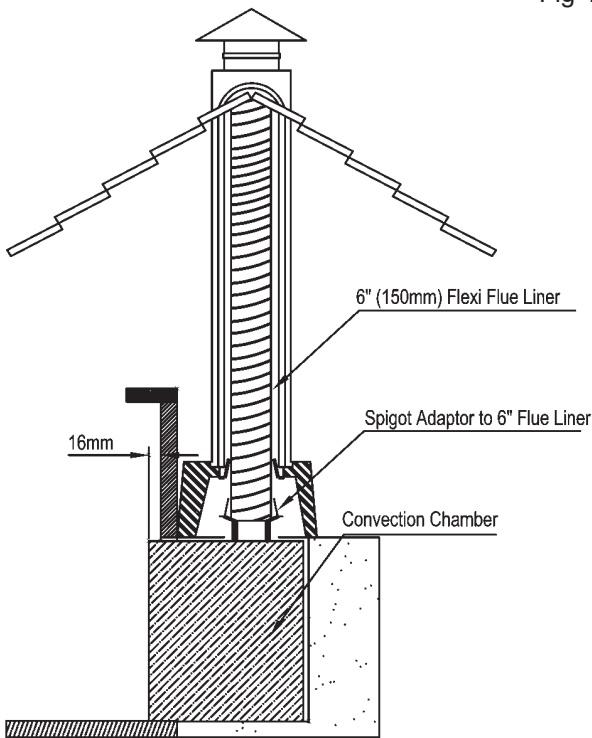
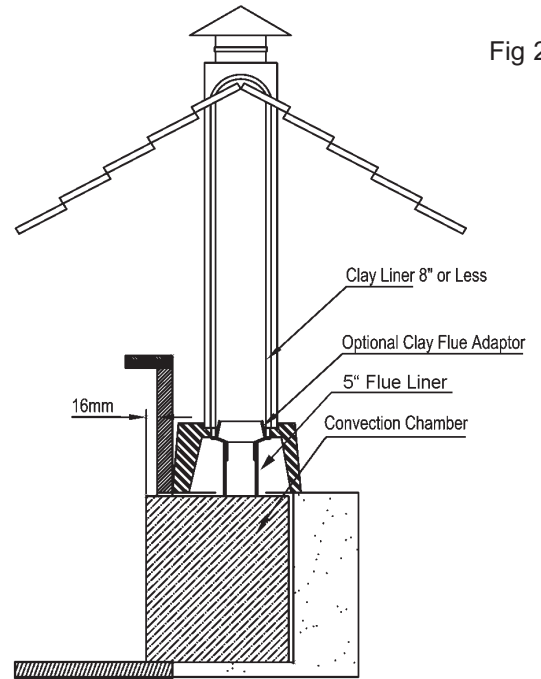

Fig 2



CO ALARMS

Building regulations require that when ever a new appliance or replacemrnt fixed solid fuel or wood/biomass appliance is installed in a dwelling a carbon monoxide alarm must be fitted in the same room as the appliance. Further guidance on the installation of the carbon monoxide alarm is available in BS EN 50292: 2002 and from the alarm manufacturer's instructions.

Provision of an alarm must not be considered a substitute for either installing the appliance correctly or ensuring regular servicing and maintenance of the appliance and chimney system.

FITTING INSTRUCTIONS

Step 1

Prepare the fireplace area with fireback or millner brick removal. Ensure the opening is suitable for fitting of the insert stove opening required, i.e. remove fire surround trim if fitted. See Fig 3.

Fig 3

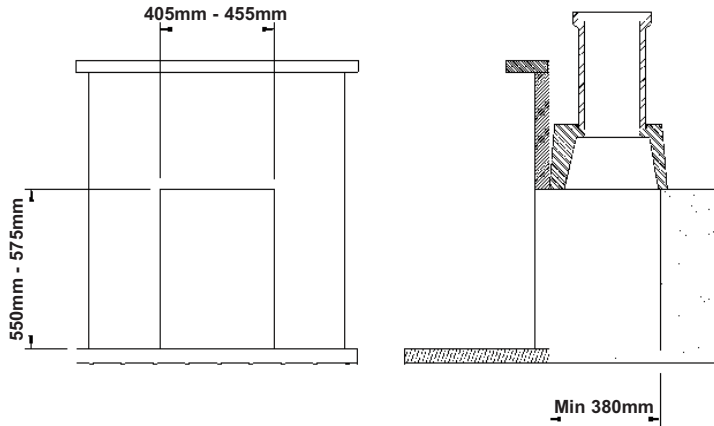

Step 2

Ensure the floor area is level with the hearth, this area needs to be level as the insert fire is screw fixed to the floor.

Step 3

Lay the external casing into the opening and position so that the front edge protrudes 16mm past the front edge of the opening. See Fig 4.

Fig 4

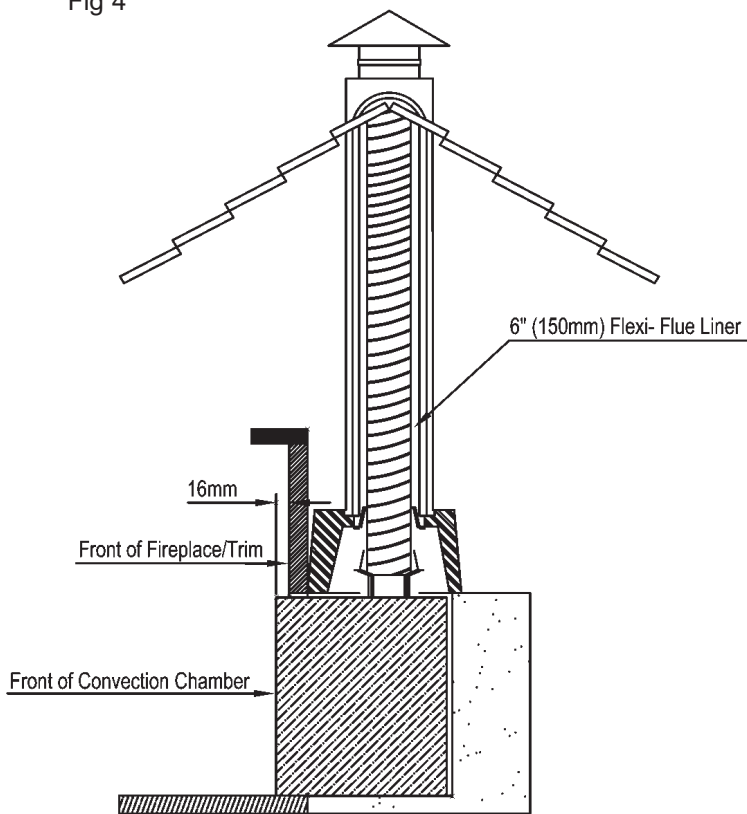

Step 4

Mark the drill location and drill the holes using a 5.5mm drill bit. Fix the casing to the floor using the self tapping screws provided. (Optional, screw fix ashlip, see Fig 7).

Step 5

Lift the stove into the external casing. Remove all internal parts as per pre-assembly instructions prior to lifting it. The stove can be lifted into the casing approximately 75mm first and then it can be pushed into the final position while taking care to lift the front edge to preserve the hearth.

Step 6

Drop the flexi flue liner down through the chimney and into the stove.

Step 7

Lay the sealing gasket on to the flue spigot, then fit the flue spigot to the end of the flexi flue liner using the 3 grub screws provided. See Fig 5.

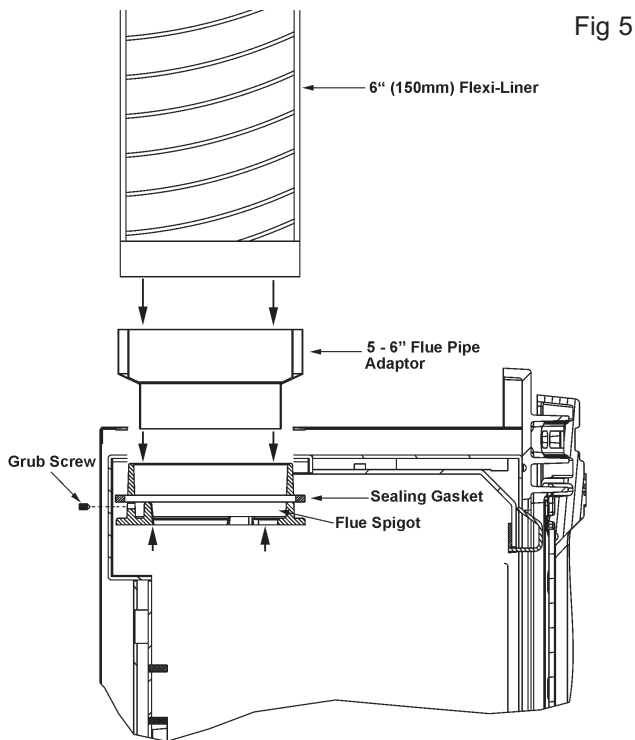

Step 8

Then using the M6 screws secure the stove to the convection chamber. Push the insert stove against the fireplace before fully tightening these bolts.

Step 9

Push the flexi liner back up through the flue outlet and fix the flue spigot into position using the M8 nuts provided. It may be necessary to cut a prop to hold the spigot in place while the fixings are being attached.

Step 10

Complete the installation of the flexi line at the top of the chimney in accordance with the manufacturers instructions.

Step 11

Fit the individual components in the following order:

1. Grate Support
2. Grate
3. Ashlip (Optional - Use if Required)
4. Cast Iron Side Liners
5. Fixed Baffle
6. Loose Baffle
7. Back Bricks
8. Side Bricks
9. Fire Fence

Fig.6

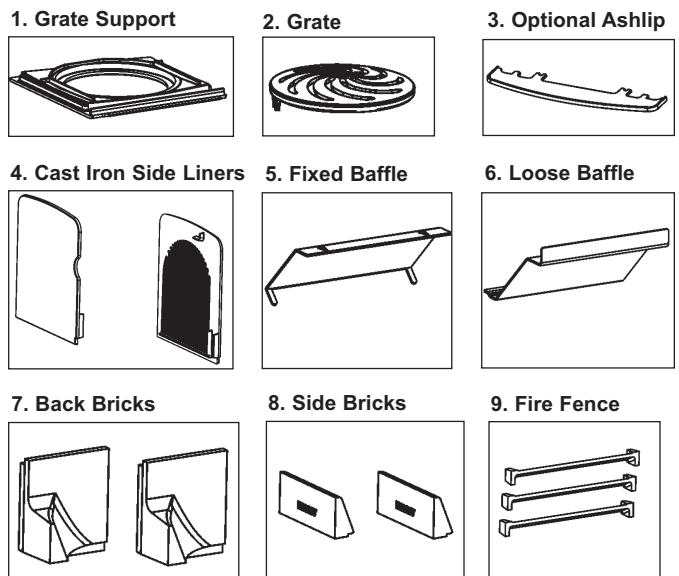

1. Grate Support

Tilt the grate support up on one side and pass it carefully through the door opening, it should then rest on three supports approx. 100mm from the floor of the stove grate.

2. Grate

The grate simply lays into the grate support but care needs to be taken that the riddling bar will rest in the middle of the fork.

3. Fitting Optional Ashlip

The ashlip is only to be used when the stove is floor mounted. The ashlip must be fully supported underneath by the hearth. The ashlip can be adhered to the hearth using a suitable adhesive after the stove has been fitted or alternatively it can be screw fixed using two screws provided. (See Fig.7).

The ashlip is to be pushed into place and has two lugs which align the ashlip from side to side between the sides of the external casing.

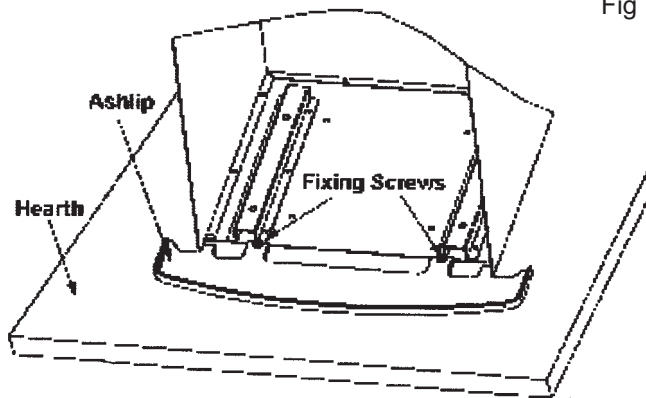

Fig 7

4. Cast Iron Side Liners

To insert the side liner bring the casting carefully towards the opening, the bottom edge needs to go towards the side it will fit to and the top edge goes to the centre of the stove. With the casting tilted like this, then the casting should pass through the opening in the front.

When the casting is in the stove, manoeuvre it into position by inserting the back edge first then the front.

5. Fixed Baffle

The baffle fits to the roof of the stove using the two M6 round head screws. With the screws in place, lift the baffle into place with the main part of the baffle to the rear of the stove, then slide the baffle so that the screws are at the tip of the slots. Tighten the screws to secure the baffle.

6. Loose Baffle

Hold the baffle by the 'L' shaped end with the fold turned up. Manoeuvre it diagonally through the door opening and then drop the rear edge to the rear of the stove. Lift the 'L' shaped edge up over the 'L' shape on the side castings.

Move the baffle as far as possible to the front and top. Then lift the back edge up and allow the baffle to rest on the top rib on the back and in the 'L' shape on the side castings. **Note:** The secondary air holes must be visible underneath the baffle.

7 & 8. Side & Back Bricks

Lay the side and back bricks in as shown.

Fig 8

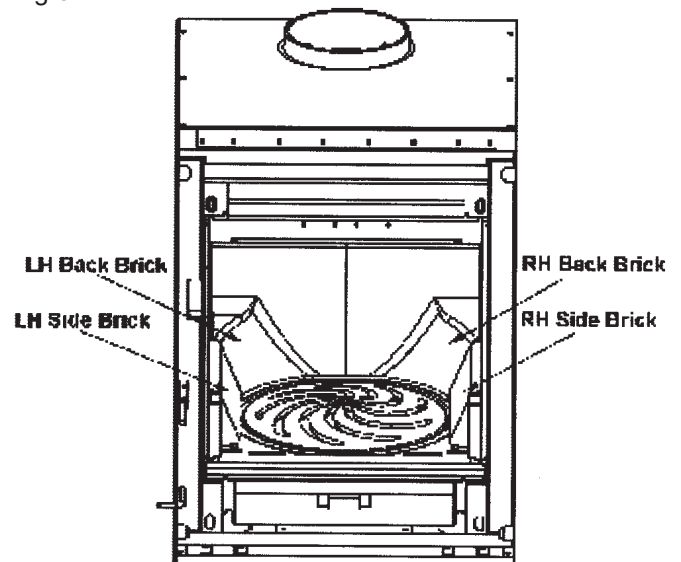

9. Fire Fence

Lay the fire fence into the slots provided ensuring that they slope from front to back so that no embers can fall out through the fire fence.

DOWN DRAUGHTS

However well designed constructed and positioned, the satisfactory performance of the flue can be adversely affected by down draught caused by nearby hills, adjacent tall buildings or trees. These can deflect wind to blow directly down the flue or create a zone of low pressure over the terminal. A suitable anti-down draught terminal or cowl will usually effectively combat direct down blow but no cowl is likely to prevent down draught due to a low pressure zone. (See Fig.9)

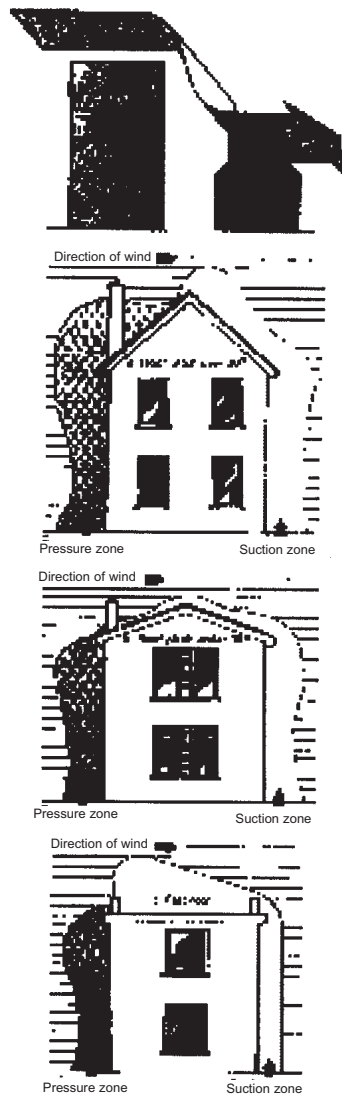

Fig 9

Air vents direct to the outside of the building should be located so that any air current produced will not pass through normally occupied areas of the room.

An air vent outside the building should not be located less than the dimensions specified within the Building Regulations and B.S. 8303: Part 1 from any part of any flue terminal. These air vents must also be satisfactorily fire proofed as per Building Regulations and B.S. 8303: Part 1.

Air vents in internal walls should not communicate with bedrooms, bedsits, toilets, bathrooms or rooms containing a shower.

Air vents traversing cavity walls should include a continuous duct across the cavity. The duct should be installed in such a manner as not to impair the weather resistance of the cavity.

Joints between air vents and outside walls should be sealed to prevent the ingress of moisture. Existing air vents should be of the correct size and unobstructed for the appliance in use. If there is an extraction fan fitted in adjacent rooms where this appliance is fitted, additional air vents may be required to alleviate the possibility of spillage of products of combustion from the appliance/flue while the fan is in operation. Refer to B.S. 8303 Part 1.

Where such an installation exists, a test for spillage should be made with the fan or fans and other appliances using air in operation at full rate, (i.e. extraction fans, tumble dryers) with all external doors and windows closed.

If spillage occurs following the above operation, an additional air vent of sufficient size to prevent this occurrence should be installed.

COMMISSIONING & HANDOVER

On completion of the installation allow a suitable period of time for any fire cement and mortar to dry out, when a small fire may be lit and checked to ensure the smoke and fumes are taken from the stove up the chimney and emitted safely to the atmosphere. **Do not run at full output for at least 24 hours.**

On completion of the installation and commissioning ensure that the operating instructions for the stove are left with the customer. Ensure to advise the customer on the correct use of the appliance with the fuels likely to be used on the stove and warn them to use only the recommended fuels for the stove.

VENTILATION AND COMBUSTION AIR REQUIREMENTS

This appliance is rated less than 5kW, therefore there is no mandatory requirements for additional air unless a flue draught stabiliser is fitted then the air requirement is 15cm². However, we suggest that it is advantageous to provide an air supply into the room.

When calculating combustion air requirements for this appliance use the following equation: 550mm² per each kW of rated output above 5 kW should be provided, where a flue draught stabiliser is used the total free area shall be increased by 300mm² for each kW of rated output. If there is another appliance using air fitted in the same or adjacent room, it will be necessary to provide an additional air supply.

All materials used in the manufacture of air vents should be such that the vent is dimensionally stable, corrosion resistant, and no provision for closure. The effective free area of any vent should be ascertained before installation. The effect of any grills should be allowed for when determining the effective free area of any vent.

Advise the user what to do should smoke or fumes be emitted from the stove. The customer should be warned to use a fire guard to BS 6539 in the presence of children, aged and/or infirm persons

LOCATION

There are several conditions to be considered in selecting a location for your stove.

- A. This product is designed to be installed into a fire place.
- B. Allowances for proper clearances to combustibles.

FLOOR PROTECTION

It is recommended that this appliance is installed on a solid, level, concrete base, a non combustible hearth conforming to current Building Regulations must extend to the front of the appliance.

CLEARANCE TO COMBUSTIBLES

This appliance must be installed in a recess, the recess should not contain any combustible materials. Wooden battens and plaster board should not be used within the clearance to combustibles. The minimum clearance to combustibles required is 550mm to the top, 350mm to the sides, 550mm directly to the front and 350mm to any combustible flooring.

Fig.10

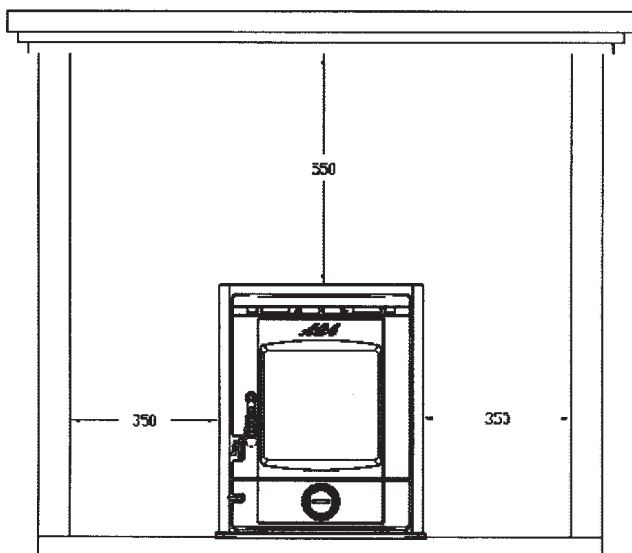
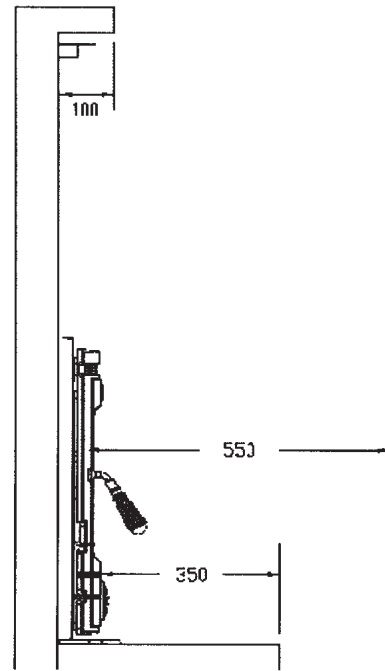

Fig.11



If the mantelpiece protrudes further than 100mm from the fireplace, then it will be necessary to have further clearance to the top of the stove. The distance the mantle protrudes past the 100mm should be added to the clearance.

For example, if the mantle protrudes 200mm, the clearance to the mantle should be 650mm. (See Figs 10 & 11).

If there is a studded wall surrounding the fireplace as in Fig.10, ensure the clearances in this Fig are adhered to.

Fig.12

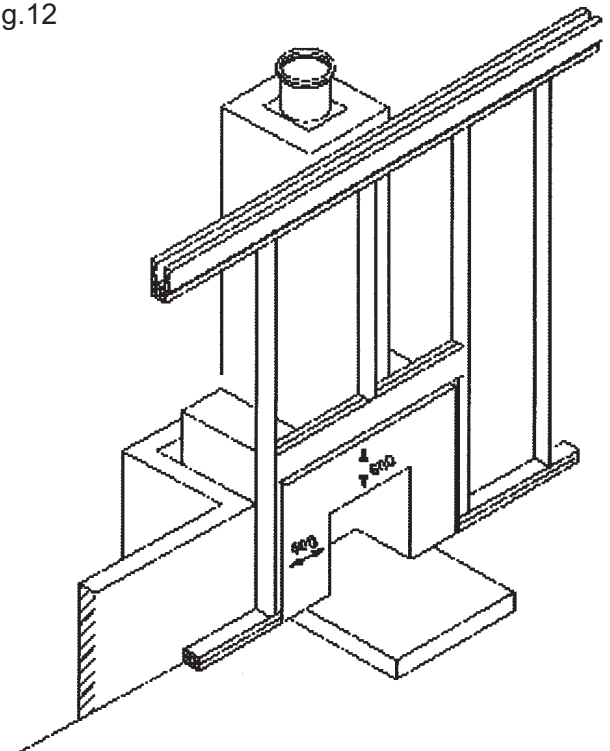

STOVE DIMENSIONS

Fig.13

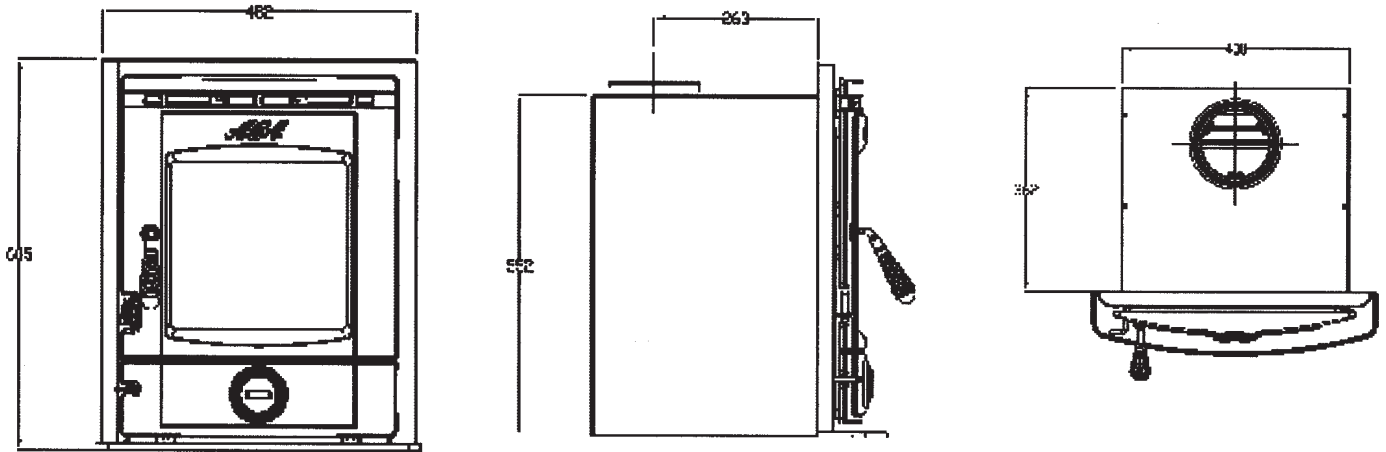

TECHNICAL DATA			
	Manufactured Smokeless Fuel		Wood Logs
Nominal Output kW	4.4 kW		4.9 kW
Typical refuelling intervals to obtain nominal outputs	MSF	2 hours	1 hour
Flue Gas Mass Flow	MSF	3.3 g/s	3.4 g/s
Flue Gas temp at nominal output	277°C		296°C
Gross Weight 100kgs			
Flue Outlet 125mm (5") into a 150mm (6") Flue Liner			Log Size 310mm
Stove Efficiency	70%		78.4%
This appliance has been tested in accordance with BS EN 13229			Log Size 310mm

PRIMARY AIR CONTROL SPIN VALVE

When burning manufactured smokeless fuels, the spin valve located near the bottom of the door, controls the primary air supply to the stove. For maximum heat output and burn rate rotate the spin valve fully in an anti-clockwise direction. For a minimum burn rate rotate the spin valve fully in a clockwise direction until fully closed. For nominal heat output the spin wheel will need to be open about 2 turns depending on the draught conditions of the chimney. You will soon learn the spin valve settings to best suit your requirements.

Fig.14

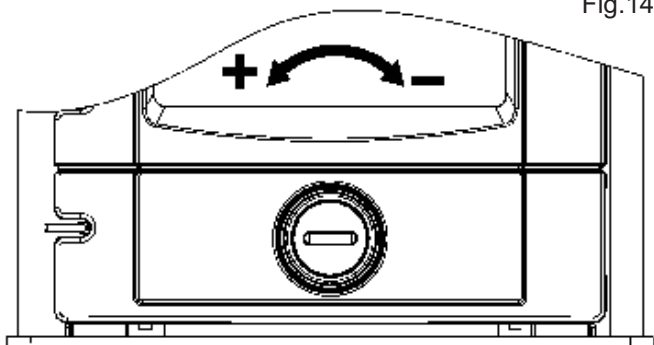

SECONDARY AIR CONTROL - SLIDER

When burning wood, push the secondary air slider situated on the left hand side of the door to the bottom of the slot. The air control is a slider operation, push the slider to the top of the slot for fully closed and to the bottom for fully open.

The control can be gradually moved between fully open and fully closed for the desired setting. Fully open will be the hottest setting, as this will provide the maximum air to the fire and will help to clean the glass even after it has become sooty. This control can be used in conjunction with the spin valve but generally the fire will perform best if the slider is used when burning wood and the spin valve is used when burning manufactured smokeless fuels. These controls are hot when the appliance is in use. Use the glove provided to operate these controls when they are hot.

Fig.15

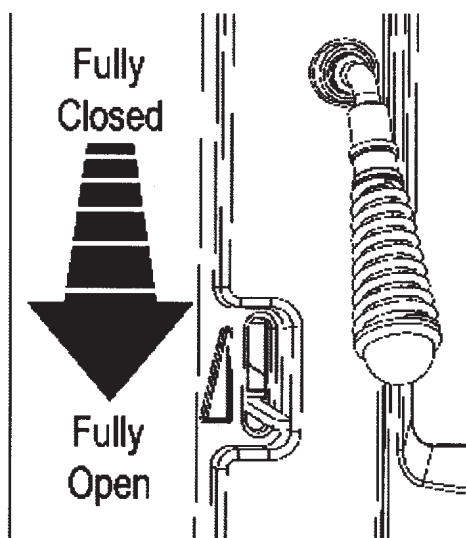
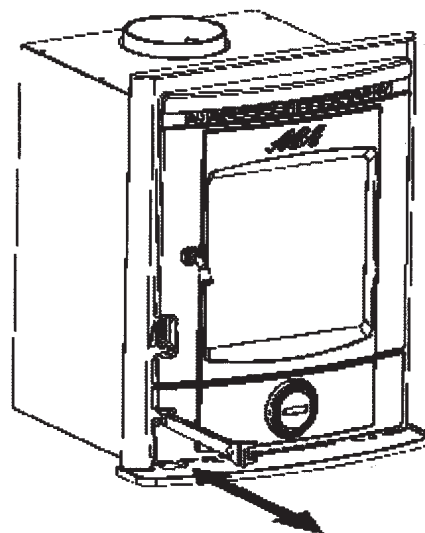

Fig.16



RECOMMENDED FUELS

This appliance has been tested using seasoned wood logs and manufactured smokeless fuels. Other fuels are commercially available and may give similar results. Do not use fuels with a Petro-coke ingredient as this may cause the grate to overheat, causing damage. Reduced outputs will result when fuels of lower calorific value are used. All fuels should be stored under cover and kept as dry as possible prior to use.

RE-FUELLING

When re-fuelling with manufactured smokeless fuel riddle the fire by connecting the grate operating tool onto the rocker connection located at the bottom front of the stove, the grate must be in the open position before riddling. Then gently pull and push the rocker arm until all dead ash has fallen through into the ashpan. Before opening the door, open the spin valve by turning it anti-clockwise, as this will help to eliminate any smoke or fly ash resident in the combustion chamber. Add fuel to fire, taking care not to overfill higher than the front firebars. Close fire door and re-set spin valve to required setting. Do not operate this appliance with the fire door open. (See Fig.16)

When burning wood the requirement to riddle the fire is much less. Do not riddle the fire with the spinwheel open but fully open the secondary air control instead. Remember to reset the controls after refuelling.

SLOW BURNING

To achieve slow burning when burning wood close the secondary air slide and open a few millimetres using the tool provided. Slow burning will cause the window glass to blacken and should not be used for a long period as it will leave sooty deposits in the flueways. Opening the air slide will increase the heat output and will clear the glass.

To obtain slow burning when burning coal, close the secondary air fully and partially open the spin valve.

DE-ASHING

Never allow the ashpan to overfill as it will cause damage to the grate. Empty the ashpan before lighting. Always ensure that ashes have thoroughly cooled before removing the ashpan. Open the fire door and remove ashpan using the operating tool. Close the fire door. When the ash is disposed of, replace the empty ashpan. (See Fig.17) Do not leave the fire unattended with the fire door open, even for a minute.

WARNING - NEVER DISPOSE OF ASH WHEN STOVE IS LIGHTING.

IMPORTANT - DAMAGE CAN OCCUR TO THE FIREBED AND GRATE ASSEMBLY IF THE ASHPAN IS NOT CLEANED OUT DAILY AND BEFORE EACH USE.

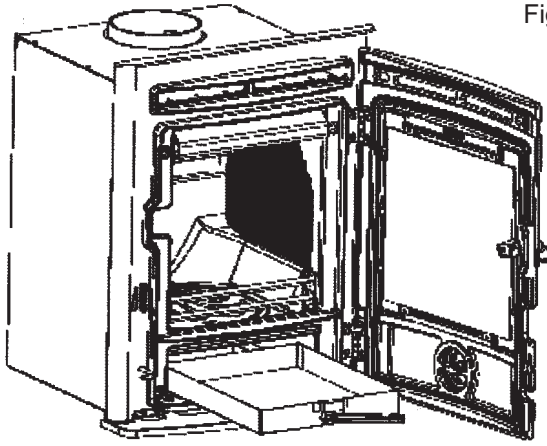

Fig.17

IMPORTANT NOTES

Now that your stove is installed and no doubt you are looking forward to many comforts it will provide, we would like to give you some tips on how to get the best results from your stove.

1. We would like if you could take some time to read the operating instructions/hints, which we are confident, will be of great benefit to you.
2. Do not burn fuel with a high moisture content, such as damp peat or unseasoned timber. This will only result in a build up of tar in the stove and in the chimney and the possibility of a chimney fire.
3. **CLEAN THE FLUE-WAYS OF THE STOVE EVERY WEEK AND ENSURE THAT THERE ARE NO BLOCKAGES. CHECK FLUEWAYS BEFORE LIGHTING ESPECIALLY AFTER A SHUT-DOWN PERIOD. PLEASE REFER TO MANUAL FOR INSTRUCTIONS.**
4. Before loading fresh fuel into the firebox, riddle fully to remove all ashes this will allow better and cleaner burning. See Re-Fuelling Section.
5. Never allow a build up of ashes in the ash pan, as this may cause the grate to burn out prematurely.
6. Allow adequate air ventilation to ensure plenty of air for combustion.
7. Do not burn rubbish/house hold plastic.
8. Clean the chimney at least twice a year.
9. Burning soft fuels such as timber and peat will stain the glass. Regular cleaning will prevent permanent staining.
10. Keep all combustible materials a safe distance away from the appliance, please see section for clearances to combustion.
11. For safety reasons never leave children or the elderly unaccompanied while stove is in use. Use a fireguard.
12. Avoid contact with appliance when in use as the stove reaches very high operating temperatures.
13. This appliance should be regularly maintained by a competent service engineer. Use only replacement parts recommended by AGA. Using unauthorised parts will invalidate your guarantee and may cause damage or injury.
14. Do not use an aerosol spray on or near the stove when it is alight.

MAINTENANCE

CREOSOTE - Formation and Need for Removal

When some fuels are burned slowly, they produce tar and other organic vapours, which combine with expelled moisture to form creosote. The creosote vapours condense in the relatively cool chimney flue of a slow-burning fire. As a result, creosote residue accumulates on the flue lining. When ignited creosote makes an extremely hot fire.

CHIMNEY CLEANING

The chimney should be cleaned twice annually. The chimney can be cleaned through the stove by remove the fire lining and the baffle. The flue liner should be cleaned in accordance with manufacturers instructions. Always use a brush with plastic bristles that is the correct size to reach all areas of the flue.

REMEMBER COAL GASES ARE TOXIC

WARNING NOTE

Properly installed, operated and maintained the stove will not emit fumes into the dwelling. Occasional fumes from de-ashing and re-fuelling may occur. However, persistent fume emission is potentially dangerous and must not be tolerated. If fume emission does persist, then the following immediate action should be taken:

- (a) Open doors and windows to ventilate the room and then leave the premises.
- (b) Let the fire go out.
- (c) Check for flue or chimney blockage and clean if required.
- (d) Do not attempt to relight the fire until the cause of the fume emission has been identified and corrected. If necessary seek expert advice.

CO ALARM - Your installer should have fitted a CO alarm in the same room as the appliance. If the alarm sounds unexpectedly, follow the instructions give under 'Warning Note' above.

The most common cause of fume emission is flueway or chimney blockage For your own safety these must be kept clean at all times.

AN ODOUR WILL EMIT FROM STOVE ON FIRST FIRING, WHEN FIRE REACHES MAXIMUM TEMPERATURE OVER A NUMBER OF HOURS THIS ODOUR WILL SUBSIDE.

IT IS BEST ADVISED TO OPEN WINDOWS DURING THIS PERIOD.

THIS ODOUR IS UNPLEASANT BUT NOT TOXIC. YOU MAY WISH TO VACATE THE ROOM WHILE THE PAINT CURES.

LIGHTING

Before lighting the stove check with the installer that the installation work and commissioning checks described in the installation instructions have been carried out correctly and that the chimney has been swept clean, is sound and free from any obstructions. As part of the stoves commissioning and handover the installer should demonstrate how to operate the stove correctly.

IMPORTANT: The first few fires should be relatively small to permit the refractory to set properly and to season the stove.

1. Before lighting the stove, ensure that any build-up in the firebox has been removed and that the ashpan has been emptied.
2. Open the spin valve by turning it anti-clockwise. Open secondary air control by pulling it down. These parts will become hot. Use the tool provided.
3. Lay a few crumpled sheets of paper on the grate and then a few small sticks, kindling or an approved firelighter. Ignite and close the door.
4. Never use inflammable liquid i.e. gasoline, petrol paraffin etc. to start or freshen up a fire in this heater.
5. When the fire is well established add fuel to the firebox. Adjust to the desired setting the spin valve and / or the secondary air slide depending on the fuel burned. (See Re-Fuelling Section).
6. To shut the fire down, do not add fuel. Make sure that the fire door is properly closed, that the spin valve is firmly shut and the secondary air slide is pushed up. Cutting off the air supply will reduce the heat output.

FIRE SAFETY

To provide reasonable fire safety the following should be given serious consideration:

1. The installation of smoke detectors.
2. A conveniently located fire extinguisher to contend with small fires resulting from burning embers.
3. A practical evacuation plan.
4. A plan to deal with a chimney fire as follows:
 - a. Notify the fire department.
 - b. Prepare occupants for immediate evacuation.
 - c. Close all openings into the stove.
 - d. While awaiting the fire department watch for ignition to adjacent combustibles from overhead stove pipe or from embers or from sparks from the chimney.

GLASS

1. How to clean:

The glass will clean itself when there is sufficient heat generated by burning fuel. If a build-up of creosote occurs on the glass it may be due to draft conditions, poor quality fuel or very slow burning for a long time. Only clean glass when the stove is thoroughly cooled. Clean with a liquid detergent taking care not to scratch the glass with any coal ash deposits.

2. Glass Replacement:

- a. Open the door fully.
- b. Remove the clips and carefully remove the broken glass.
- c. Clean the glass recess in the door.
- d. Place the glass into the door recess and replace the four corner clips.
- e. Tighten screws.
- f. Replace glass only with ceramic glass 5mm thick.

SUMMER SHUTDOWN

For summer shutdown of the stove, ensure all ashes have been cleaned from the ash compartment and that the air control is open, to avoid condensation in the stove firebox and possible corrosion during this shutdown period.

STRETTON INSERT STOVE EXPLODED VIEW

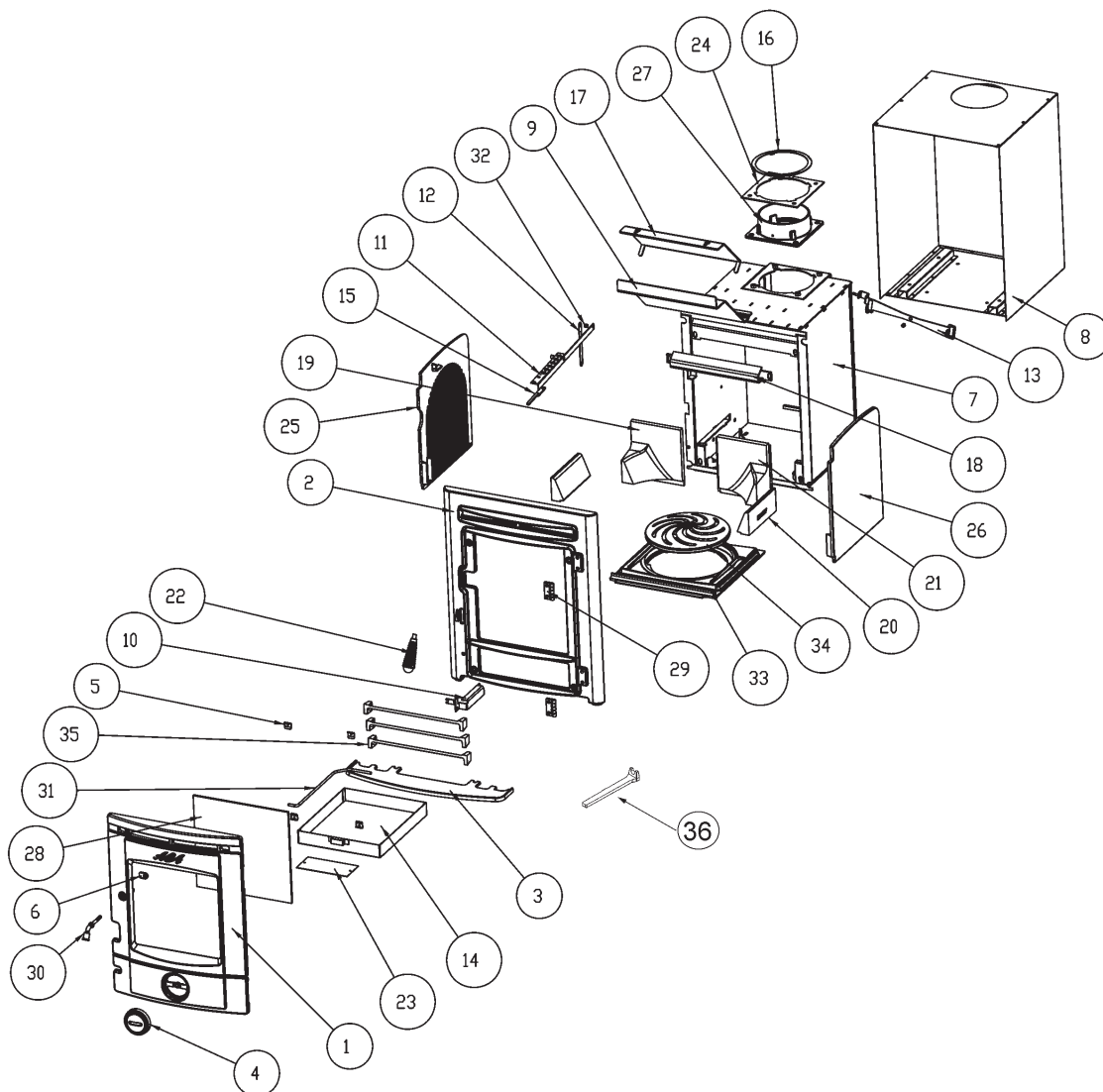

- | | |
|--|--|
| 1. FIRE DOOR - B00605AXX | 19. LH BACK BRICK - H00203AXX |
| 2. FRONT - B00606AXX | 20. SIDE BRICK - H00207AXX |
| 3. ASHLIP - B00607AXX | 21. RH BACK BRICK - H00208AXX |
| 4. SPIN VALVE - B00608AXX | 22. MIN SPRING HANDLE - L00539AXX |
| 5. WINDOW CLIP - F00896BXX | 23. DATA PLAQUE - N00500AXX |
| 6. DOOR CATCH - F00928AXX | 24. FLUE GASKET - P00102AXX |
| 7. COMBUSTION CHAMBER - F00989AXX | 25. LH SIDE PLATE - Q00750AXX |
| 8. 16" CONVECTION CHAMBER - F00990AXX | 26. RH SIDE PLATE - Q00751AXX |
| 9. BOTTOM BAFFLE - F00991AXX | 27. 5" FLUE - Q00752AXX |
| 10. PULL ROD SUPPORT BRACKET - F00992AXX | 28. GLASS - T00095AXX |
| 11. SECONDARY AIR OP LEVER - F00993AXX | 29. HINGE - U00153AXX |
| 12. SECONDARY AIR CONNECTOR BAR - F00994AXX | 30. DOOR AXLE - V00857AXX |
| 13. SECONDARY AIR PLATE - F00995AXX | 31. PULL ROD - V00935AXX |
| 14. ASHPAN - F00997AXX | 32. SPACER - V00956AXX |
| 15. LEVER - F01007AXX | 33. GRATE SUPPORT - Z00035AXX |
| 16. SEAL PLATE - F01031AXX | 34. GRATE - Z00036AXX |
| 17. TOP BAFFLE - F01032AXX | 35. FIRE FENCE - Z00037AXX |
| 18. SECONDARY AIR BAFFLE - F01036AXX | 36. OPERATING TOOL - B00009DXX |

AGA,
Station Road,
Ketley, Telford,
Shropshire, TF1 5AQ,
UK

