



AGA Wren Non Boiler Stove

(Smoke Exempt)



This appliance is hot while in operation and retains its heat for a long period of time after use. Children, aged or infirm persons should be supervised at all times and should not be allowed to touch the hot working surfaces while in use or until the appliance has thoroughly cooled.

When using the stove in situations where children, aged and/or infirm persons are present a fireguard must be used to prevent accidental contact with the stove. The fireguard should be manufactured in accordance with BS 8423:2002.

INSTALLATION AND OPERATING INSTRUCTIONS

TABLE OF CONTENTS

	PAGE NO.
1. Installation & Operating Instructions	2
2. General	2
Handling	2
Fire Cement	2
Asbestos	2
Metal Parts	2
3. The Clean Air Act 1993 & Smoke Control Areas	2
4. Pre-Installation	3
5. Chimney / Flues	3
6. Top Flue Exit	3
7. Rear Flue Exit	3
8. Down Draughts	3
9. Ventilation & Combustion Air Requirements	4
10. Commissioning & Handover	5
11. Location	5
12. Floor Protection	5
13. Clearance to Combustibles	5
14. Stove Dimensions	6
15. Technical Data	6
16. Air Controls	7
17. Recommended Fuels	7
18. Riddling	7
19. Refuelling	7
Refuelling onto a low firebed	7
Fuel overloading	7
Operation with door left open	8
20. Dampers / Air Controls left open	8
21. De-Ashing	8
22. Disposal of Ash	8
23. Maintenance	8
24. Chimney Cleaning	8
25. Important Notes	9
26. Lighting	10
27. Fire Safety	10
28. CO Alarms	10
29. Fire Brick Replacement	10
30. Baffle Removal	10
31. Enamel Cleaning	10
32. Glass	11
Glass Replacement	11
33. Prolonged Periods Of Non Use	11
34. Exploded View	12
35. Trouble Shooting	13

INSTALLATION & OPERATING INSTRUCTIONS

NOTE: Please note that it is a legal requirement under England & Wales Building Regulations that the installation of the stove is either carried out under Local Authority Building Control approval or is installed by a Competent Person registered with a Government approved Competent Persons Scheme. HETAS Ltd operate such a Scheme and a listing of their Registered Competent Persons can be found on their website at www.hetas.co.uk.

GENERAL

When installing, operating and maintaining your stove respect basic standards of fire safety. Read these instructions carefully before commencing the installation. Failure to do so may result in damage to persons or property. Save these instructions for future reference.

Special care must be taken when installing the stove such that the requirements of the Health & Safety at Work Act are met.

Any alteration that is not approved by AGA, could invalidate the approval of the appliance, operation of the warranty and could also affect your statutory rights. Use only authorised replacement parts.

Handling

Adequate facilities must be available for loading, unloading and site handling.

Fire Cement

Some types of fire cement are caustic and should not be allowed to come into contact with the skin. In case of contact with the skin wash immediately with plenty of water.

Asbestos

This stove contains no asbestos. If there is a possibility of disturbing any asbestos in the course of installation then please seek guidance and use appropriate protective equipment.

Metal Parts

When installing or servicing this stove care should be taken to avoid the possibility of personal injury.

THE CLEAN AIR ACT 1993 AND SMOKE CONTROL AREAS

The Clean Air Act 1993 and Smoke Control Areas" Under the Clean Air Act local authorities may declare the whole or part of the district of the authority to be a smoke control area. It is an offence to emit smoke from a chimney of a building, from a furnace or from any fixed boiler if located in a designated smoke control area. It is also an offence to acquire an "unauthorised fuel" for use within a smoke control

area unless it is used in an "exempt" appliance ("exempted" from the controls which generally apply in the smoke control area).

The Secretary of State for Environment, Food and Rural Affairs has powers under the Act to authorise smokeless fuels or exempt appliances for use in smoke control areas in England. In Scotland and Wales this power rests with Ministers in the devolved administrations for those countries. Separate legislation, the Clean Air (Northern Ireland) Order 1981, applies in Northern Ireland. Therefore it is a requirement that fuels burnt or obtained for use in smoke control areas have been "authorised" in Regulations and that appliances used to burn solid fuel in those areas (other than "authorised" fuels) have been exempted by an Order made and signed by the Secretary of State or Minister in the devolved administrations.

Further information on the requirements of the Clean Air Act can be found here :
<http://smokecontrol.defra.gov.uk/>

Your local authority is responsible for implementing the Clean Air Act 1993 including designation and supervision of smoke control areas and you can contact them for details of Clean Air Act requirements"

The Wren stove has been recommended for use in smoke controlled areas when burning wood logs, it is fitted with a factory modified air control to allow a minimum amount of combustion air when the air controls are set at minimum.

IMPORTANT WARNING: This stove must not be installed into a chimney that serves any other heating appliance. There must not be an extractor fan fitted in the same room as the stove as this can cause the stove to emit fumes into the room.

The installation must be completed in accordance with current National and European Standards and Local Codes. It should be noted that the requirements and these publications may be superseded during the life of this manual.

PRE-INSTALLATION

Before using the stove for the first time all remaining stickers must be removed, all accessories must be removed from the ashpan, check if any items have become dislodged during transport.

CHIMNEY/FLUES

The stove is a radiant room heater and must be connected to a proper type chimney/flue for safe evacuation of products of combustion. The stove is supplied with a 125mm flue spigot, the flue installation will require a 125 to 150mm increaser which must be fitted within 1 meter of flue outlet.

The chimney/flue must have a diameter of 150mm or equivalent cross sectional area. Never connect to a smaller size chimney/flue. Do not connect to a chimney/flue serving another appliance. A minimum chimney/flue height of 4.5 metres from the flue spigot on the stove to the top of the chimney/flue is required. The chimney/flue must be constructed of material capable of withstanding a soot fire in the chimney/flue which can lead to temperatures of 1000 degrees. The chimney/flue must be constructed with sockets uppermost so that when condensation occurs within the pipe, it should flow down the inside of the pipe that it will transfer to the inner of the next pipe without seeping through the joints. The chimney/flue should provide a minimum continuous draught of 12 pascals, if the stove is connected into an existing chimney where the refractory flue liner is of a diameter in excess of 200mm the chimney should be relined using a flexible flue liner. The flexi liner is not recommended to be connected directly to the appliance, there should be a minimum of 0.6 meters rigid flue pipe coming off the appliance. The chimney/flue should be designed to allow for cleaning of the stove, use pipes with cleaning doors where necessary.

Avoid the use of 90 degree elbows, use 2 x 45° bends instead. Horizontal runs of flue pipe should be avoided, where it is unavoidable the maximum permitted horizontal run is 150mm. The chimney/flue must have the necessary clearance distance from combustible material. The chimney termination must be free of any obstructions, see requirements under Approved Document J, available to download at www.planningportal.gov.uk

For guidance when installing new chimney systems or relining existing chimneys please refer to BS EN 15287:

TOP FLUE EXIT

For the top outlet configuration, remove the blanking plate from the hob, remove the flue spigot from the back plate and fix it to the hob. Fix the outlet blanking plate to back plate (see Fig. 2). Push the flue outlet connector pipe (not supplied) into the flue spigot and cement into place using approved fire cement ensuring that no cement blocks the flue passageway.

Fig.1

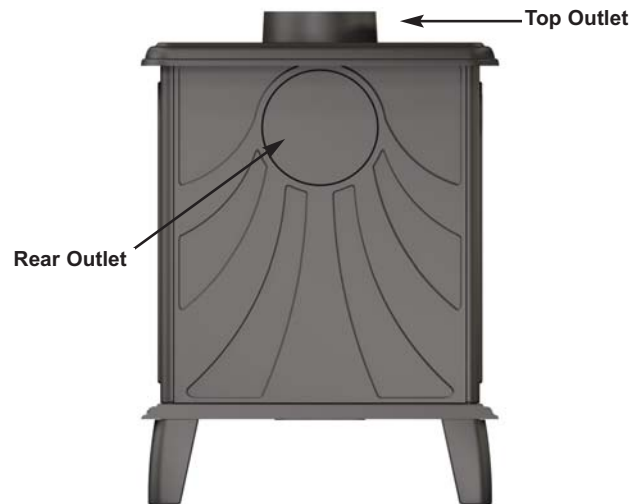

REAR FLUE EXIT

Push the flue connector pipe (not supplied) into the flue spigot and cement into place using approved fire cement ensuring that no cement blocks the flue passageway (see Fig.1).

DOWN DRAUGHTS

However well designed constructed and positioned, the satisfactory performance of the flue can be adversely affected by down draught caused by nearby hills, adjacent tall buildings or trees. These can deflect wind to blow directly down the flue or create a zone of low pressure over the terminal. A suitable anti-down draught terminal or cowl will usually effectively combat direct down blow but no cowl is likely to prevent down draught due to a low pressure zone. (See Fig.2)

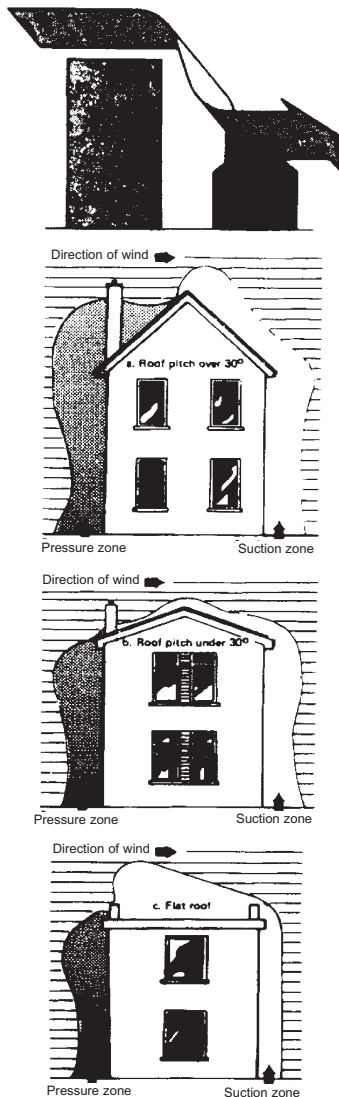

Fig 2

If there is another appliance using air fitted in the same or adjacent room, it will be necessary to provide an additional air supply.

All materials used in the manufacture of air vents should be such that the vent is dimensionally stable, corrosion resistant, and no provision for closure. Air inlet grills should be positioned so they do not become liable to blockage.

The effective free area of any vent should be ascertained before installation. The effect of any grills should be allowed for when determining the effective free area of any vent.

Air vents direct to the outside of the building should be located so that any air current produced will not pass through normally occupied areas of the room. An air vent outside the building should not be located less than the dimensions specified within the Building Regulations and B.S. 8303: Part 1 from any part of any flue terminal. These air vents must also be satisfactorily fire proofed as per Building Regulations and B.S. 8303: Part 1.

Air vents in internal walls should not communicate with bedrooms, bedsits, toilets, bathrooms or rooms containing a shower.

Air vents traversing cavity walls should include a continuous duct across the cavity. The duct should be installed in such a manner as not to impair the weather resistance of the cavity.

Joints between air vents and outside walls should be sealed to prevent the ingress of moisture. Existing air vents should be of the correct size and unobstructed for the appliance in use. If there is an extraction fan fitted in adjacent rooms where this appliance is fitted, additional air vents may be required to alleviate the possibility of spillage of products of combustion from the appliance/flue while the fan is in operation. Refer to B.S. 8303 Part 1.

Where such an installation exists, a test for spillage should be made with the fan or fans and other appliances using air in operation at full rate, (i.e. extraction fans, tumble dryers) with all external doors and windows closed.

If spillage occurs following the above operation, an additional air vent of sufficient size to prevent this occurrence should be installed.

VENTILATION AND COMBUSTION AIR REQUIREMENTS

A permanent air supply must be provided in accordance with Building Regulation ADJ and BS 8303.

Please refer to Building Regulations Part J to determine the size of permanent air vent required, as follows:

Install where draft stabilizer is fitted:

Permanently open vents as below:

If design air permeability $>5.0\text{m}^3/(\text{h.m}^2)$ then
 $300\text{mm}^2/\text{kW}$ for first 5kW of appliance rated output
 $850\text{mm}^2/\text{kW}$ for balance of appliance rated output
 If design air permeability $<5.0\text{m}^3/(\text{h.m}^2)$ then
 $850\text{mm}^2/\text{kW}$ of appliance rated output (4)

Install where no draft stabilizer is fitted:

Permanently open vents as below:

If design air permeability $>5.0\text{m}^3/(\text{h.m}^2)$ then
 $550\text{mm}^2/\text{kW}$ of appliance rated output above 5kW
 If design air permeability $<5.0\text{m}^3/(\text{h.m}^2)$ then
 550mm^2 per kW of appliance rated output (4)

Note:- If there is any work that is being carried out that would effect the air quality supplied to the stove such as sanding a floor or glueing linoleum etc. the stove must be out of operation. The dust or vapours may be a potential hazard, the air supply and local area needs to be thoroughly ventilated before putting the stove in operation again.

Extractor Fan

There must not be an extractor fan fitted in the same room as the stove as this can cause the stove to emit smoke and fumes into the room.

COMMISSIONING & HANDOVER

On completion of the installation allow a suitable period of time for any fire cement and mortar to dry out, when a small fire may be lit and checked to ensure the smoke and fumes are taken from the stove up the chimney and emitted safely to the atmosphere. **Do not run at full output for at least 24 hours.**

On completion of the installation and commissioning ensure that the operating instructions for the stove are left with the customer. Ensure to advise the customer on the correct use of the appliance with the fuels likely to be used on the stove and warn them to use only the recommended fuels for the stove.

Advise the user what to do should smoke or fumes be emitted from the stove. The customer should be warned to use a fire guard to BS 8423:2002 in the presence of children, aged and/or infirm persons.

LOCATION

There are several conditions to be considered in selecting a location for your stove.

- A. Allowances for proper clearances to combustibles of the stove and flue pipes.
- B. The product must be installed on a non combustible hearth with adequate load bearing capacity.
- C. Fluing considerations; length of flue, length of horizontal run, flue termination.
- D. Location within area to be heated.

FLOOR PROTECTION

The product must be placed on a non combustible hearth in accordance with UK Building Regulation part ADJ. The hearth must be suitably robust and to the appropriate dimensions.

For free standing installations it is acceptable to place the stove on a solid sheet of non combustible material minimum 12mm thick, as the product will not raise the temperature of the upper surface of the hearth up to 100 °C.

CLEARANCE TO COMBUSTIBLES

Side wall to stove	32" 800mm
Back wall to stove	32" 800mm
Corner	25" 635mm
Mantle clearance	25" 635mm

It is recommended that this appliance is sited next to and on a non-combustible surface. A minimum all round clearance of 150mm will allow air circulation and not impede the performance of the stove. See Fig.3.

Fig.3

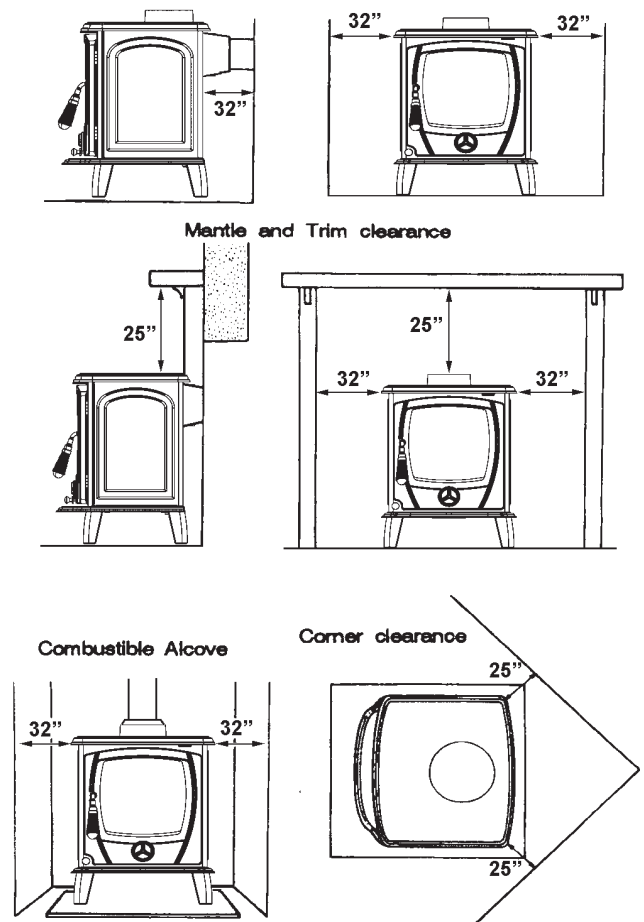

STOVE DIMENSIONS

Fig. 4

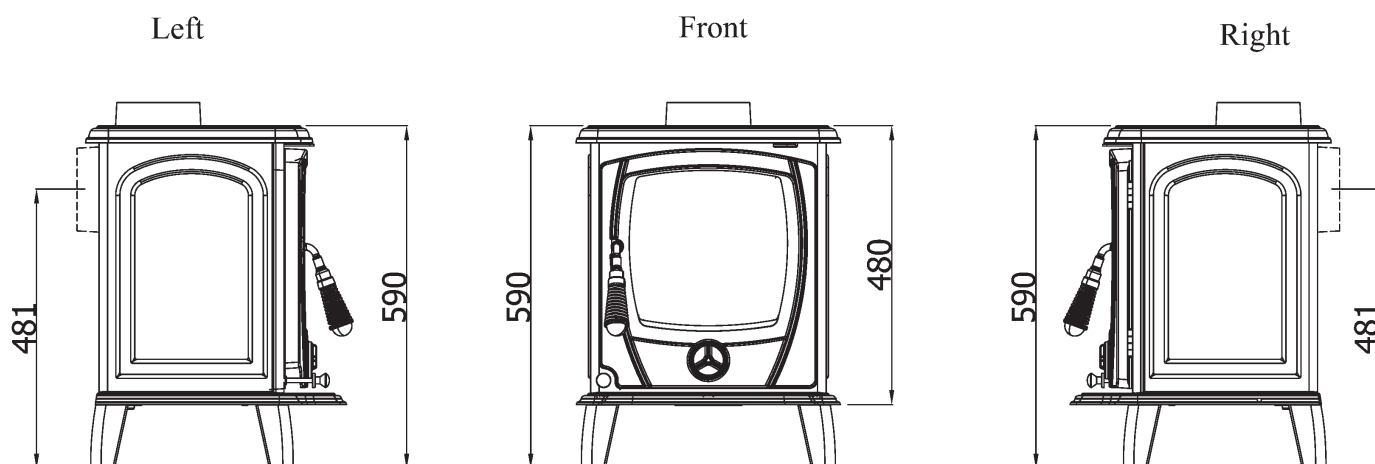

Note: Dimensions stated are in millimeters and may be subject to a slight +/- variation.

TECHNICAL DATA		
FUEL	WOOD	ANCIT
Nominal Output - Room	4.8 kW	4.9 kW
Typical refuelling intervals to obtain nominal outputs	1 Hour	1 Hour
Fuel Gas Mass Flow	4.4 g/s	3.7 g/s
Flue Gas Temp at Nominal Output	262 °C	275 °C
Gross Weight	105 kgs	
Flue Outlet	125mm	
Log Size	310mm	
This appliance has been tested in accordance with BS EN 13240		

NOTE:-

A suitable chimney (minimum profile, chimney draft, tightness, etc) is a basic condition for the proper functioning of fireplace stoves. See professional advice before installing the stove. Chimney values are included in the attached technical sheet. A smoke shutter or a draft regulator should be installed for chimneys with too strong a draft. Such a draft can cause problems during operation, e.g. intensive burning, high fuel consumption and can also lead to permanent damage to the stove.

AIR CONTROLS

The stove has two independent air controls.

1. The primary air control or spin valve. Rotate the spin valve clockwise to close and anticlockwise to open. See Fig.5

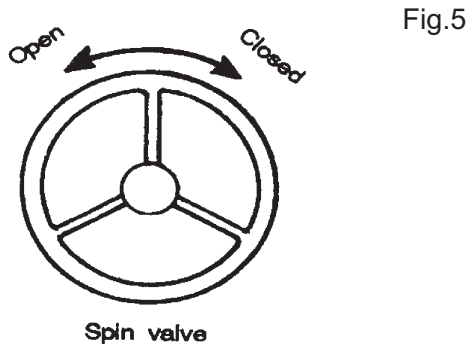

2. The secondary / window wash air control. This is located over the door on the right hand side. See Fig.6

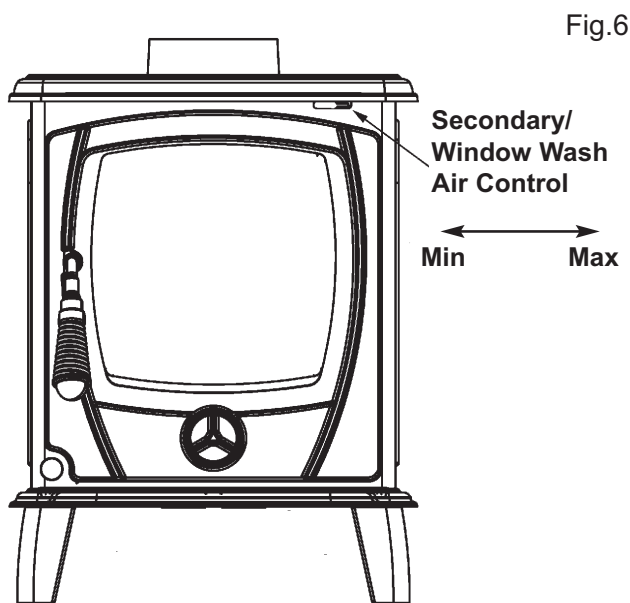

When the fire has established, while burning wood the spin valve can be closed fully or less than half a turn open. The fire can then be controlled using the secondary air control.

When burning approved smokeless coal the secondary air control can be moved to the minimum position. The fire can then be controlled using the spin valve.

RECOMMENDED FUELS

This appliance has been tested using seasoned wood logs and smokeless coal. The appliance is suitable for intermittent operation in smoke controlled areas using wood logs and smokeless coal approved for use in smoke controlled areas.

Wood should be kept under cover and kept as dry as possible prior to use. Wood logs of diameter less than 80mm and no more than 310mm long are recommended.

Do not use liquid fuels or any fuels with a Petro-coke ingredient as this may cause the grate to overheat resulting in damage.

RIDDLING

Riddle the fire by connecting the grate operating tool onto the rocker connection located at the bottom front of the stove, then gently pull and push the rocker arm until all dead ash has fallen through into the ashpan. See Fig.7

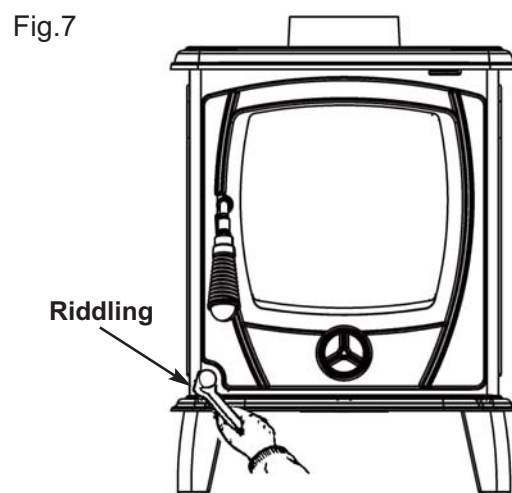

RE-FUELLING

When refuelling, always refuel onto a bed of glowing embers, riddle gently if necessary. When refuelling, adjust the secondary air control to the fully open position and open the spin valve 2 turns for approximately 3 minutes allowing the new refuel charge to establish combustion before adjusting the air control to the desired setting.

Refuelling on to a low fire bed

If there is insufficient burning material in the firebed to light a new fuel charge, excessive smoke emission can occur. Refuelling must be carried out onto a sufficient quantity of glowing embers and ash that the new fuel charge will ignite in a reasonable period. If there are too few embers in the fire bed, add suitable kindling to prevent excessive smoke.

Fuel overloading

The maximum amount of wood (1.4 kilograms per hour) should not be exceeded, overloading can cause excess smoke.

Operation with door left open

Operation with the door open can cause excess smoke. The appliance must not be operated with the appliance door left open except as directed in the instructions.

Remember to reset the controls after refuelling.

DAMPERS / AIR CONTROLS LEFT OPEN

Operation with the air controls or appliance dampers open can cause excess smoke. The appliance must not be operated with air controls, appliance dampers or door left open except as directed in the instructions.

DE-ASHING

NOTE - DO NOT OVERFILL THE FIREBOX

Never allow the ashpan to fill more than half way as it will cause damage to the grate. Empty the ashpan before lighting. Always ensure that ashes have thoroughly cooled before removing the ashpan. Open the fire door and remove ashpan using the operating tool. Close the fire door. When the ash is disposed of, replace the empty ashpan. Do not leave the fire unattended with the fire door open, even for a minute. See Fig.8

Fig.8

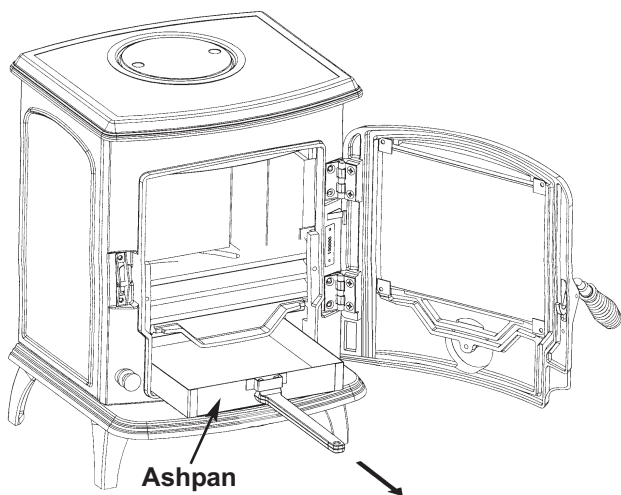

DISPOSAL OF ASH

Ashes should be placed in a metal container with a tight fitting lid. The closed container of ashes should be on a non-combustible floor or on the ground well away from all combustible materials pending final disposal. If the ashes are disposed of by burial in soil or other wise locally dispersed they should be retained in the closed container until all cinders have thoroughly cooled.

WARNING - NEVER DISPOSE OF ASH WHEN STOVE IS LIGHTING.

IMPORTANT - DAMAGE CAN OCCUR TO THE FIREBED AND GRATE ASSEMBLY IF THE ASHPAN IS LEFT TO OVER FILL.

MAINTENANCE

CREOSOTE - Formation and Need for Removal

When some fuels are burned slowly, they produce tar and other organic vapours, which combine with expelled moisture to form creosote. The creosote vapours condense in the relatively cool chimney flue of a slow-burning fire. As a result, creosote residue accumulates on the flue lining. When ignited creosote makes an extremely hot fire.

CHIMNEY CLEANING

The chimney should be cleaned twice annually. The chimney can be cleaned through the stove by removing the top baffle. The flue liner should be cleaned in accordance with manufacturers instructions. Always use a brush with plastic bristles that is the correct size to reach all areas of the flue.

The chimney must be swept and examined for soundness and suitability before the appliance is installed. Remedial action should be taken if required seeking expert advice if necessary. Where the chimney is believed to have previously served an open fire installation it is possible that the higher flue gas temperature from a closed appliance may loosen deposits that were previously firmly adhered, with the consequent risk of flue blockage. It is therefore recommended that the chimney be swept a second time within a month of regular use after installation.

WARNING NOTE

Properly installed, operated and maintained the stove will not emit fumes into the dwelling. Occasional fumes from de-ashing and re-fuelling may occur. However, persistent fume emission is potentially dangerous and must not be tolerated. If fume emission does persist, then the following immediate action should be taken:

- (a) Open doors and windows to ventilate room and then leave the premises.
- (b) Let the fire out.
- (c) Check for flue or chimney blockage and clean if required.
- (d) Do not attempt to relight the fire until the cause of the fume emission has been identified and corrected. If necessary seek expert advice.

CO ALARM

Your installer should have fitted a CO alarm in the same room as the appliance. If the alarm sounds unexpectedly, follow the instructions given under "Warning Note" above.

The most common cause of fume emission is flue-way or chimney blockage. For your own safety these must be kept clean at all times.

IMPORTANT NOTES

Now that your stove is installed and no doubt you are looking forward to many comforts it will provide, we would like to give you some tips on how to get the best results from your stove.

1. We would like if you could take some time to read the operating instructions/hints, which we are confident, will be of great benefit to you.
2. Do not burn fuel with a high moisture content, such as damp or unseasoned timber. This will only result in a build up of tar in the stove and in the chimney and the possibility of a chimney fire.
3. **ONCE A MONTH CHECK TO ENSURE THAT THERE IS NO BUILD UP OF SOOT OR BLOCKAGES AT THE STOVE FLUE EXIT BEFORE LIGHTING ESPECIALLY AFTER A SHUT-DOWN PERIOD. THIS MAY REQUIRE REMOVAL OF THE TOP BAFFLE.**
4. Before loading fresh fuel into the firebox, riddle gently, this will allow better and cleaner burning. See Re-Fuelling Section.

5. Never allow a build up of ashes in the ash pan, as this may cause the grate to burn out prematurely.
6. Allow adequate air ventilation to ensure plenty of air for combustion.
7. Do not burn rubbish/house hold plastic. Do not burn manufactured timber which contains glue. Do not burn processed or pressure treated timber as this will create a very intense fire over a short period of time which will damage the appliance.
8. Clean the chimney at least twice a year.
9. Burning at a low burn rate or unseasoned timber will stain the glass. Regular cleaning will prevent permanent staining.
10. Keep all combustible materials a safe distance away from the appliance, please see section for clearances to combustion.
11. For safety reasons never leave children, elderly or infirmed unaccompanied while stove is in use. Use a fireguard for solid fuel appliances in accordance with BS 8423:2002.
12. Avoid contact with appliance when in use as the stove reaches very high operating temperatures.
13. This appliance should be regularly maintained by a competent service engineer. Use only replacement parts recommended by AGA. Using unauthorised parts will invalidate your guarantee and may cause damage or injury.
14. Do not use an aerosol spray on or near the stove when it is alight.

AN ODOUR WILL EMIT FROM STOVE ON FIRST FIRING, WHEN FIRE REACHES MAXIMUM TEMPERATURE OVER A NUMBER OF HOURS THIS ODOUR WILL SUBSIDE.

IT IS BEST ADVISED TO OPEN WINDOWS DURING THIS PERIOD.

THIS ODOUR IS UNPLEASANT BUT NOT TOXIC. YOU MAY WISH TO VACATE THE ROOM WHILE THE PAINT CURES.

WARNING: THE AIR CONTROLS/DOOR HANDLE WILL BECOME HOT WHEN THE STOVE HAS BEEN IN OPERATION FOR SOME TIME, USE THE GLOVE/TOOLS PROVIDED WHEN REFUELLING OR ADJUSTING AIR CONTROLS.

LIGHTING

Before lighting the stove check with the installer that the installation work and commissioning checks described in the installation instructions have been carried out correctly and that the chimney has been swept clean, is sound and free from any obstructions. As part of the stoves commissioning and handover the installer should demonstrate how to operate the stove correctly.

WARNING:- The paint on the stove gets finally cured when the stove is lit, during the first fire the paint can soften, the doors of the stove should be closed but not latched during the first fire, otherwise the rope on the door can become embedded in the paint during final curing.

IMPORTANT: The first few fires should be relatively small to permit the refractory to set properly and to season the stove.

1. Before lighting the stove, ensure that any build-up in the firebox has been removed and that the ashpan has been emptied.
2. Open both air controls to maximum.
3. Lay some firelighters on the grate with two handfuls of kindling. The kindling must be cut into thin lengths and laid across each other in layers to allow for a quick lightup. Ignite the firelighters and close the door.
4. When the firebed has fully ignited and is starting to die back add 3 small logs, or a small quantity of smokeless fuel.
5. Approximately 2 minutes after adding the logs the door can be closed, but air settings remain un-altered.
6. When the fire from the 3 logs is dying back a normal fuel load of approx 1.2kg is to be added to the fire. Leave the air controls unaltered for 5 minutes to ensure the new fuel load is well alight before moving the air controls to the desired settings.

FIRE SAFETY

To provide reasonable fire safety the following should be given serious consideration:

1. The installation of smoke detectors.
2. A conveniently located fire extinguisher to contend with small fires resulting from burning embers.

3. A practical evacuation plan.
4. A plan to deal with a chimney fire as follows:
 - a. Notify the fire department.
 - b. Prepare occupants for immediate evacuation.
 - c. Close all openings into the stove.
 - d. While awaiting the fire department watch for ignition to adjacent combustibles from overhead stove pipe or from embers or from sparks from the chimney.

CO ALARMS

Building regulations require that whenever a new or replacement fixed solid fuel or wood/ biomass appliance is installed in a dwelling a carbon monoxide alarm must be fitted in the same room as the appliance. Further guidance on the installation of the carbon monoxide alarm is available in BS EN 50202:2012 and from the alarm manufacturers instructions.

Provision of an alarm must not be considered a substitute for either installing the appliance correctly or ensuring regular servicing and maintenance of the appliance and chimney system.

FIRE BRICK REPLACEMENT

Lift the fire fence up to remove it. Slide the bricks to the front of the stove, lift the brick and allow the top edge to tilt towards the centre of the stove. Remove the brick and fit the replacement in the reverse order.

Note:-

Stress fractures in the firebrick do not have an effect on the combustion or the service life of the stove, however if the metal behind the bricks becomes exposed from a fractured brick replace immediately as this will cause damage to the stove.

BAFFLE REMOVAL

The top Baffle is a loose item that rests in position on top of the middle baffle and on top of a protrusion from the back of the front casting. There are positioned stops on the two back corners to prevent it from sliding back along the middle baffle. To remove it, first remove one of the side bricks and slide the baffle forward while supporting its weight. When the position tabs are clear of the middle baffle, lift the back edge in over the middle baffle, then the front edge can be lowered and the baffle removed. To replace the baffle reverse the steps

and ensure it is resting on the protrusion in front and that the positional stops are interlocked with the middle baffle. See Fig.9

Fig.9

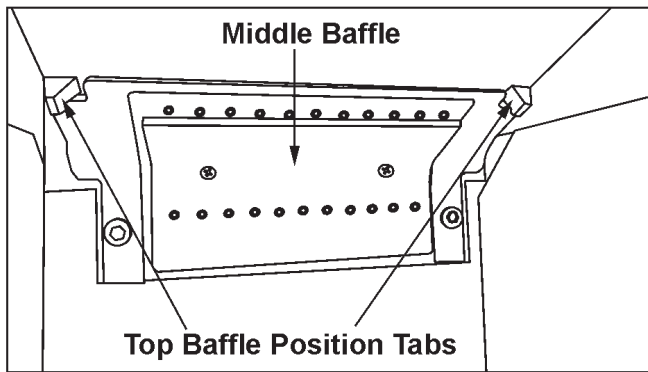

ENAMEL CLEANING

General cleaning must be carried out when the stove is cool.

If this stove is finished in a high gloss vitreous enamel, to keep the enamel in the best condition observe the following tips:

1. Wipe over daily with a soapy damp cloth, followed by a polish with a clean dry duster.
2. For stubborn deposits a soap impregnated pad can be carefully used on the vitreous enamel.
3. Use only products recommended by the Vitreous Enamel Association, these products carry the vitramel label.

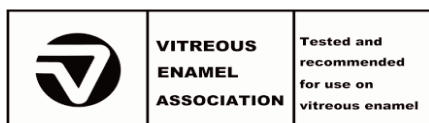

4. **DO NOT USE ABRASIVE PADS OR OVEN CLEANSERS CONTAINING CITRIC ACID ON ENAMELLED SURFACES. ENSURE THAT THE CLEANSER MANUFACTURERS INSTRUCTIONS ARE ADHERED TO.**

GLASS

1. How to clean:

The glass will clean itself when there is sufficient heat generated by burning fuel. If a build-up of creosote occurs on the glass it may be due to draft conditions, poor quality fuel or very slow burning for a long time. Only clean glass when the stove is thoroughly cooled. Clean with a liquid detergent taking care not to scratch the glass with any ash deposits.

Fig.10

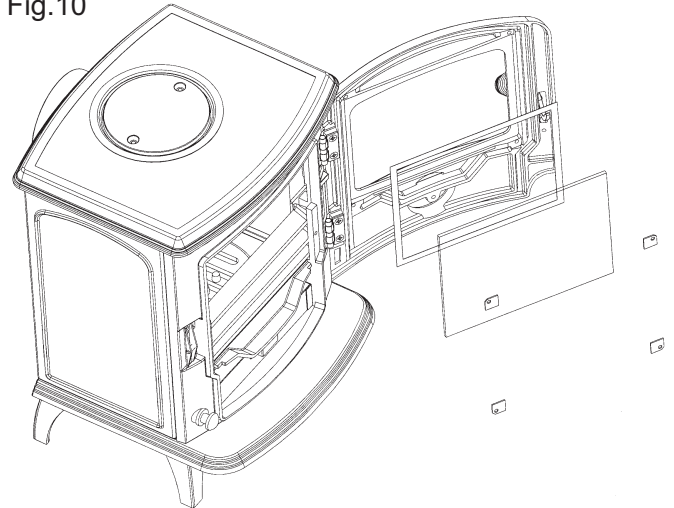

2. Glass Replacement: (See Fig.10)

- a. Open the door fully.
- b. Remove the clips and carefully remove the broken glass.
- c. Clean the glass recess in the door.
- d. Place the glass into the door recess and replace the four corner clips.
- e. Tighten screws.
- f. Replace glass only with ceramic glass 5mm thick.

PROLONGED PERIODS OF NON USE

If the stove is to be left unused for a prolonged period of time then it should be given a thorough clean to remove ash and unburned fuel residues. To enable a good flow of air through the appliance to reduce condensation and subsequent damage, leave the air controls fully open.

It is important that the flue connection, any appliance baffles or throat plates and the chimney are swept prior to lighting up after a prolonged shutdown period.

EXPLODED VIEW

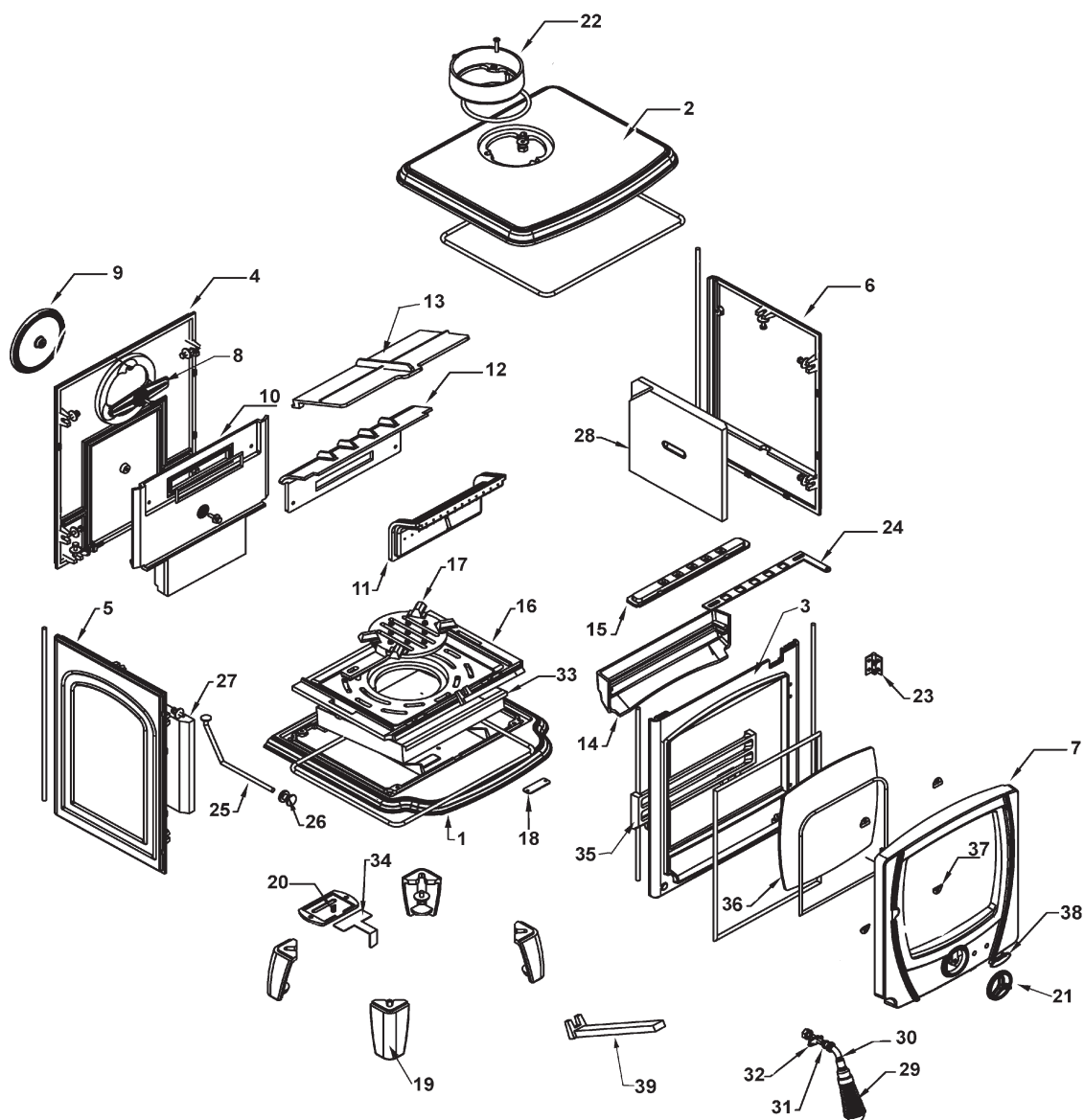

1. BASE - **AF0501**
2. HOB - **0502**
3. FRONT - **0503**
4. BACK - **0504**
5. LH SIDE - **AF0505**
6. RH SIDE - **AF0506**
7. DOOR - **0507B**
8. BLANKING PLATE LOCKING BAR - **C125Y**
9. FLUE COVER BLANKING PLATE - **C125**
10. BACK BRICK - **0511**
11. LOWER BAFFLE - **0517**
12. MIDDLE BAFFLE - **0516**
13. TOP BAFFLE - **0518-CR**
14. AIR WASH BASE - **AF0509**
15. AIR WASH COVER - **0556**
16. GRATE FRAME - **0514-CR**
17. GRATE - **AF0515-CR**
18. DATA PLAQUE - **CAL0101-ZJ**
19. LEG - **0523**
20. BACK AIR DAMPER - **CA0903**
21. SPIN VALVE - **CAF0765**

22. SPIGOT - **I125**
23. DOOR HINGE - **CA1602**
24. AIR WASH SHUTTER - **CA1113-05SE**
25. RIDDLING ROD - **CA1401-SM05**
26. PULL ROD KNOB - **CA010402**
27. LH SIDE BRICK - **FR0512R**
28. RH SIDE BRICK - **FR0512L**
29. FIRE DOOR HANDLE - **CA0108-6**
30. FIRE DOOR HANDLE AXLE - **CA0101-ZH**
31. SPRING WASHER - **CA0502**
32. DOOR CATCH - **CA1505**
33. ASHPAN - **CA1205**
34. BACK AIR PLATE - **CA0901**
35. FIRE FENCE - **AF0520-CR**
36. DOOR GLASS - **CA1005B**
37. DOOR GLASS CLIPS - **CA1112**
38. DOOR BADGE - **CAL0101**
39. OPERATING TOOL - **CA0105**

TROUBLE SHOOTING

SYMPTOM	POSSIBLE CAUSES	REMEDY
Stove Difficult To Light	Air controls set incorrectly	Air controls must be set to maximum settings on initial light-up
	Moisture content of fuel too high	Ensure fuel is sufficiently dry
Fire Burns Too Quickly	Air controls set incorrectly	Adjust Air controls
	Rope seals perished/worn	Replace rope seals
	Excessive Chimney Draught	Seek professional chimney advice
Fire Burns Too Slowly/Low Heat Output To The Room	Air controls set incorrectly	Adjust Air controls
	Insufficient flue draught	Seek professional chimney advice
	Ash buildup	Do not allow ashpan to overfill
Fire Bricks Cracked	Normal wear and tear	Replace firebricks when they begin to crumble as apposed to showing minor cracks
Grate Cracked	Build up of ash causing overheating	Replace the grate and do not allow ashpan to overfill
	Operation with the ash door open	While the stove is in operation the door should be closed
	Burning non approved fuel	Burn correct fuel
Glass Sooting Up	Air wash not working	Open the air wash control
	Moisture content of fuel too high	Ensure fuel is sufficiently dry
	Insufficient flue draught	Seek professional chimney advice
	Air controls set to minimum settings	Operate the stove at or close to the nominal output
Smoking On Refuelling	Air controls set incorrectly	Air controls should be fully open prior to refuelling
	Insufficient flue draught	Seek professional chimney advice
	Chimney or flueways in stove have become partially blocked	Clean the flueways in the stove. If problem persists have the chimney cleaned by a suitable competent person
	Lack of combustion air	Ensure adequate sized air vent / air supply to the room
	Top baffle fitted incorrectly	Consult instructions to ensure baffle fitted in correct orientation

SYMPTOM	POSSIBLE CAUSES	REMEDY
Creosote/Tar Build-up in Firebox and on Flue Pathways	Insufficient flue draught	Seek professional chimney advice
	Moisture content of fuel too high	Ensure fuel is sufficiently dry
	Fuel excessively dirty	Use correct fuel
	Air controls set to minimum settings	Constant low burning can produce excessive soot
Smells From Stove/Installation	Final cure of the painted surfaces	This odour is unpleasant but not toxic. It is best advised to ventilate the room and leave unoccupied.
	Incorrect sealant used	All flue Joints must be sealed with fire cement only
	Insufficient flue draught	Seek professional chimney advice
Water In Base Of Stove	Condensation on light up	It is acceptable to have a little condensation on start up, when the fire is established condensation should not be present
	Moisture content of fuel too high	Use correct fuel



AGA,
Station Road,
Ketley, Telford,
Shropshire, TF1 5AQ,
UK

