

Kinder

FIRES FOR LIFE

GAS FIRES 2018

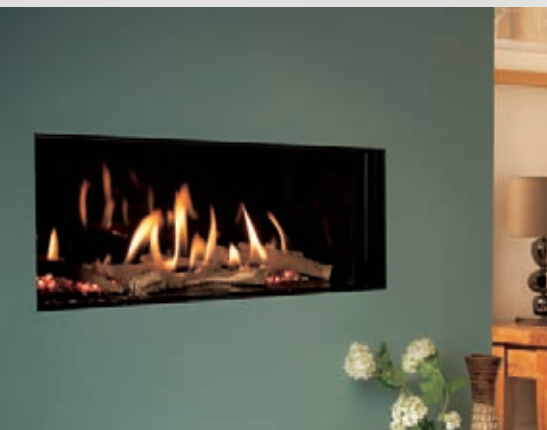

MADE IN BRITAIN

Kinder

FIRES FOR LIFE

At Kinder, we know how important it is to create a stylish and relaxing living environment.

That's why we've developed this collection of premium gas fires and surrounds to complement all tastes and lifestyles.

“I believe our success stems from a combination of innovative design, investment in technology and the highest quality manufacturing standards.

As a result all Kinder fires carry a 15 year guarantee to reflect my belief in their quality and durability, and our experienced Kinder retailers are hand-picked to give you the very best advice and service.

This brochure has been designed to make the purchase of your new Kinder fire as simple as possible. I hope you will find it both informative and inspiring.”

Michael Jones



BFM Europe
BRITISH FIRE MANUFACTURERS



BRITISH MADE QUALITY

Kinder is crafted by BFM Europe, the fastest growing domestic fire producer in the country with an unequalled reputation for quality and service. Every Kinder branded gas fire is developed and manufactured in Britain at our purpose built, state-of-the-art facility in Stoke-on-Trent.



Kinder fires for life	4
Product testing and certification	5
Kinder 15 year guarantee	6
Before you begin	7



high efficiency

Conventional Flue	8	Balanced Flue	8
Wall Inset - Glass Fronted		Wall Inset - Glass Fronted	
Celena	10	Celena BF	10
Atina HE	12	Atina BF	12
Eden HE	14	Eden BF	14
Eden Elite	16	Eden Elite BF	16
Hearth Inset - Glass Fronted		Hearth Inset - Glass Fronted	
Passion HE	18	Dakota BF	46
Nevada HE	20	Revolution BF	48
Kalahari HE	22	Fireplace Suites - Glass Fronted	
Camber HE	24	Avignon Celena BF Suite	28
Oasis HE	26	Avignon Eden Elite BF Suite	34
Fireplace Suites - Glass Fronted			
Avignon Celena Suite	28		
Lille Celena Suite	30		
Rennes Celena Suite	32		
Avignon Eden Elite Suite	34		
Hearth Inset - Open Fronted			
Nevada Plus	36		
Kalahari Plus	38		
Camber Plus	40		
Oasis Plus	42		
Oasis	44		



standard efficiency

Conventional & Powerflue	9		
Hearth Inset - Open Fronted			
Nevada & Nevada Powerflue	50	Camber	54
Kalahari/Black Magic & Kalahari/Black Magic Powerflue	52		
Finishing Touches		Powerflue Fires	
Trims, Fascias & Frets		Installation Possibilities	
Balanced Flue	58		
Drawings & Dimensions			



Kinder

FIRES FOR LIFE

There is nothing like the immediate warmth and comfort of a Kinder Gas fire

Designed to suit your lifestyle with a combination of appealing looks, outstanding warmth and practical attention to detail - Kinder designs gas fires for all tastes, from traditional to contemporary, and including many models available as powerflue and balanced flue options.



All our fires feature a Flame Supervision Device (FSD) and all conventional flue models feature an Oxygen Depletion Sensor (ODS) for maximum safety. The ODS is a device which shuts off the gas supply to the main burner in the unlikely event of a fault. The FSD is a device which detects the presence of a flame, and in the absence of that flame, prevents uncontrolled release of gas to the burner.

Everything you need to know about gas fires, from alternative power supplies to flue types is on the following pages, so you can sit back and relax with Kinder from the start.

Kinder products are stocked by leading independent fire specialists located throughout the UK. These retailers are fully trained to make the choice and subsequent installation of your Kinder fire as seamless as possible.

Visit www.KinderGasFires.co.uk to find your nearest retailer.



This logo signifies that the product is fully compliant with the Eco design directive Commission Regulation (EU) 2015/1188.



Product Testing & Certification

All our gas fires are independently tested, approved and verified by the British Standards Institution (BSI) to meet industry standards for performance, safety and efficiency.



All our fires are independently tested, approved and verified by the British Standards Institution (BSI). They are not owned by the government, industry or shareholders, which means that they can be totally objective with regards testing and certification. This gives their assessments more authority than those of an organization that has a vested interest in promoting its members.

They have some of the most experienced

and knowledgeable staff in the world and are recognised internationally for their technical expertise, quality services and in-depth knowledge of gas and electrical product testing and certification.

The wide-ranging capability of their testing facilities and the broad expertise and knowledge of their testing and certification staff ensures our products are rigorously tested with the utmost integrity.



Kinder 15 year guarantee

We understand that your gas fire is going to be the heart of your home. That's why we are passionate about ensuring our gas fires offer the ultimate in build quality and looks.



Eden Elite with brushed steel trim
PAGE 16

From the beginning, our Design Team sets the standard by creating new and innovative products, so you'll find exactly the fire you have in mind. Then there's our Development Team. They consistently deliver higher safety and efficiency ratings to give you total confidence.

Before we commence manufacture, all models are assessed and approved by leading independent organisations and each fire rigorously checked by our Quality Control Department prior to leaving our state-of-the-art facility.

All in all, guaranteeing that when you settle down in front of a Kinder fire, you'll have the very best in gas fire technology behind it.

Every Kinder gas fire carries a 15 year Comprehensive Guarantee* providing you with reassurance and peace of mind. This means that your fire is guaranteed for fifteen years against manufacturing and material defects, including parts and labour. The guarantee is subject to our 'Conditions of guarantee' including annual service and annual replacement of the oxy-pilot assembly.

We offer this guarantee, unlike other manufacturers, as a sign of our commitment to the highest standards of build quality, ensuring that life will revolve around your Kinder fire for many years to come. In-line with gas industry practice, we recommend that all gas appliances should be serviced annually by a Gas Safe Register engineer to ensure continued safe operation and optimum performance throughout the lifetime of the product. Gas Safe Register engineers are available directly through our Service Department.

Before you begin

There is a Kinder fire for all tastes, from traditional to contemporary chic. However, before you make your final selection, please take time to consider the following:

Radiant or Convector?

A **radiant fire** emanates heat from the combustion chamber only, which is why Kinder radiant fires incorporate a glowing back panel to maximise heat output. A **convector fire** has the added benefit of a heat exchanger attached to the back of the fire. This draws cool air in and sends it back out into the room as hot air, maximising heat output whilst keeping your fuel bills down.

Power

Your gas supply will either be Natural Gas or LPG, depending on the area in which you live.



Natural Gas - The most common gas supply.



LPG - Alternative for houses with no Natural Gas supply.

Chimney or Flue

Your choice of fire will be dictated by the type of chimney or flue you have. If you're not sure, then take a look at your roof and cross-reference it with the simple guide on the right. It is also worth noting that a slimline fire will fit virtually any chimney or flue, whereas a full-depth often requires a traditional chimney or rebate on the fire surround. Please confirm your flue type by consulting your Kinder Stockist before purchase.



Brick Chimney
A conventional brick chimney is recognisable by a chimney stack with a terracotta pot or gas terminal.



Pre-fabricated Flue
This is an interlocking metal flue tube system identifiable by a metal flue and terminal on the roof and a metal flue box behind the fire.

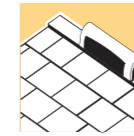

Pre-Cast Flue
Built from concrete or clay blocks, pre-cast flues provide a rectangular section flue. They can be identified by a ridge vent or metal flue tube and terminal on the roof. All fires featuring this icon are suitable for pre-cast flues conforming to BS EN 1858.

No Chimney or Flue

Some properties have no chimney or flue, in which case a balanced flue or powerflue is required.



Powerflue fires expel the flue gases directly outside the building through the use of an electronically driven fan unit mounted on the external wall. A sophisticated microprocessor monitors performance and automatically shuts off the fire in the unlikely event of operation failure.

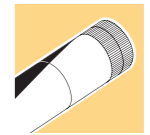

Balanced Flue fires vent directly outside through a horizontal co-axial pipe (one pipe within a larger pipe). The outer pipe draws air in from the outside and the inner pipe expels combustion gases. An electricity supply is not required for these products.

Controls

Gas is wonderfully controllable, but which type of control suits you best? The discretion of manual ignition, concealed behind the removable ash pan... the convenience of slide control...or the luxury and style of remote control?

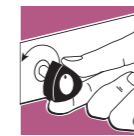

Manual Control
Simple and discreet. The control system is located behind the fire's fret or trim. Once the fire is lit rotate the control knob to adjust the flame height and heat output.



Slide Control
A convenient control system which is located on the top right-hand side of the fire. Push and hold the lever down to ignite and move it up and down to adjust the flame height and heat output.



Fully Remote with Thermostat
The remote control handset can be used to light the fire as well as to adjust the flame height and heat output. In addition, the handset contains the extra benefit of a thermostatic control to regulate room temperature and a programmable timer that can be pre-programmed to ensure your room will be warm whenever you wish.

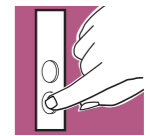

Fully Automatic Easy Flame Control
Discreet, easy access buttons are used to ignite the fire and adjust heat and flame height



Fully Remote Control
The remote control handset is used to light the fire as well as to adjust the flame height and heat output.

Fire Back Panel

Kinder offers a range of fire back panels chosen to compliment each individual fire. In some cases you may be offered a choice of back panel – look out for the symbols on the right.



Plain Black



Glossy Black Enamel Back

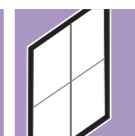

Vermiculite Back

high efficiency

Get up to 93.5% energy efficiency from a Kinder High Efficiency gas fire

Kinder has always had a reputation as a manufacturer of some of the most efficient fires on the market. Now we are setting new industry standards with the Kinder HE high efficiency range: exceptional heat output combined with lower running costs compared to standard gas fires.

Kinder's R&D team has invested in developing the technology to meet the key objective of producing gas fires that save energy and as a result, help to keep costs down.

Inspired design. Advanced technology.

Our glass fronted high efficiency Conventional and Balanced Flue fires are available in a range of Wall Inset and Hearth Inset models as well as Fireplace Suites. In addition, we have a range of open fronted high efficiency Conventional Flue Hearth Inset fires offering more options and choices.



Conventional Flue fires

Glass Fronted Fires

Our range of high efficiency conventional flue glass fronted fires have an energy efficiency of up to 86%. They have a glass panel across the front of the fire which radiates the heat generated from the fuel bed directly into the room. The glass panel concentrates the radiant heat so that more heat is forced into the room and less is lost through the chimney. Combined with convected heat which is produced by cool air drawn into the base of the fire through the heat exchanger and then emitted as warm air through the gap above the canopy, making these the most efficient conventional flue fires available.

Open Fronted Fires

Our high efficiency conventional flue open fronted fires can reach an energy efficiency of up to 68.3%. These fires provide the look and feel of a real open fire providing both radiant and convected heat. Radiant heat is emitted from the coal effect fuel bed and the convected heat is generated by cool air drawn into the base of the fire which passes through a heat exchanger and is then emitted as warm air through the gap above the canopy.

Balanced Flue fires

Glass Fronted Fires

Our range of high efficiency balanced flue fires have an energy efficiency of up to 93.5%. Designed for those who want all the benefits of a gas fire but don't have a built in chimney or flue in their home, a balanced flue fire comes with its own flue terminal which is vented directly through an outside wall. They are glass fronted, completely room sealed appliances and work by drawing and venting external air via a pair of co-axial tubes into the fire for combustion purposes.



standardfires

Conventional & Powerflue fires

Open Fronted Fires

Standard fires can achieve a direct heat output of up to 3.1kW. It is recommended that these products are not suitable for use as a primary heat source but they are ideal if you are looking for a great fireplace feature for occasional use.





Celena

The Celena gas fire has been designed to be suitable for homes with or without a brick chimney or pre-fabricated flue. This fire has perfect proportions that are complimented by an attractive large viewing area with a pleasing display of tall lively flames.

The slimline balanced flue option has an impressive energy efficiency of 90.5% and comes with an attractive lower fuel bed log arrangement.

The conventional flue option offers a raised log fuel bed and has an energy efficiency of 79.6%. The Celena comes complete with a thermostatic remote control to ensure your room is always at a comfortable temperature.

A polished silver, brass, or black trim is available to purchase as an optional extra.

Specifications

Description: Full depth inset gas fire
Type of Heat: Radiant & Convected

	Conventional flue	Balanced flue
Useful energy efficiency	79.6%	90.5%
Energy efficiency class	D	B
Fuel type	Natural gas	Natural gas
Direct heat output	3.9kW	3.9kW

Fuel Effect	Back Panel	Model Number	
Log	Matt Black	KPRLPBRN	KCBLPBRN
	Cream Vermiculite	KPRLTVRN	KCBLTVRN

Safety: Flame Supervision Device & Oxygen Depletion Sensor
Air vent required: Not normally

Dimensions

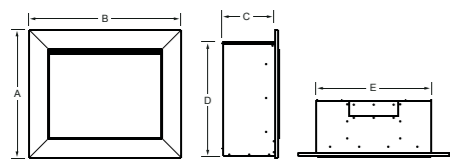

- A 641mm
- B 762mm
- C 259mm
- D 574mm
- E 574mm

Slimline Balanced Flue dimensions on page 58.

- Natural Gas
- Brick Chimney
- Pre-fabricated
- Balanced Flue
- Thermostatic Remote
- Plain Black
- Vermiculite



Celena conventional flue with cream vermiculite fire back and brass effect trim.



Celena conventional flue with black fire back and black painted trim.



Celena conventional flue
Watch the video



Shown: Celena Slimline BF with matt black enamel fire back and polished silver trim
Watch the video

Atina HE

Atina HE's perfect petite proportions and fabulous black reflective interior combined with a spellbinding flame makes this little hole-in-the-wall gas fire a magnificent centre-piece for smaller modern living areas.

The Atina HE features a heat output of 3.3kW and is controlled by a fully sequential remote control system* with thermostatic operation so you can always maintain a comfortable room temperature that suits you.

*A 240V 3amp mains electricity supply is required. Please refer to installation manual.

Specifications

Description: Full depth inset gas fire
Type of Heat: Radiant & Convected

	Conventional flue	Balanced flue
Useful energy efficiency	70.8%	72.8%
Energy efficiency class	F	F
Fuel type	Natural gas	Natural gas
Direct heat output	3.3kW	3.3kW

Fuel effect	Control type	Model Number	
Log	Remote	KHALOORN	KHBLOORN2
White Stones			

Safety: Flame Supervision Device & Oxygen Depletion Sensor
Air vent required: Not normally

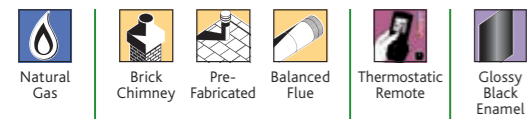
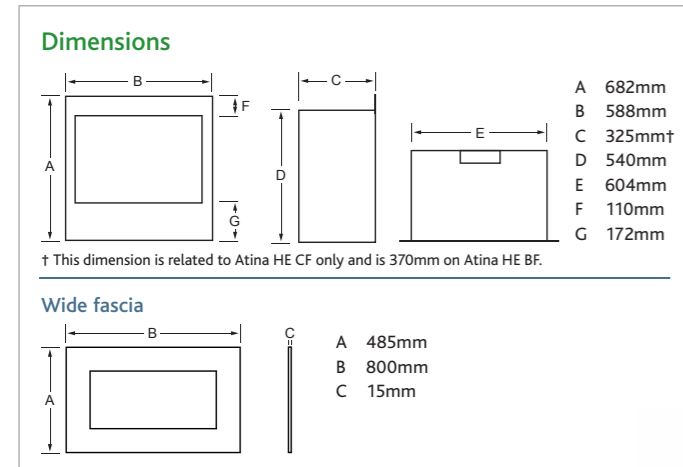

Trimless with white stones



Wide antique brass fascia and logs



Shown: Atina HE with a polished silver fascia and white stones

high efficiency Conventional & Balanced Flue

Wall Inset – Glass Fronted



Eden HE

This glass fronted landscape hole-in-the-wall fire has an incredible 84.3% energy efficiency and up to 4.8kW heat output. It features an enchanting flame picture and comes with a choice of log or white stone fuel bed.

The Eden HE has been designed as a trimless* fire for a very minimalist appearance, or team with an optional designer trim for a more prominent centrepiece.

*A 240V 3amp mains electricity supply is required to power the remote control system.

Please refer to installation manual.

Specifications

Description: Full depth inset gas fire
Type of Heat: Radiant & Convected

	Conventional flue	Balanced flue
Useful energy efficiency	83%	84.3%
Energy efficiency class	D	D
Fuel type	Natural gas	Natural gas
Direct heat output	5.2kW	4.8kW

Fuel effect	Control type	Model Number	
Log/White Stones	Remote	KHVG00RN	KBFG00RN2

Safety: Conventional Flue – Flame Supervision Device & Oxygen Depletion Sensor
Balanced Flue – Flame Supervision Device
Air vent required: Not normally

Dimensions

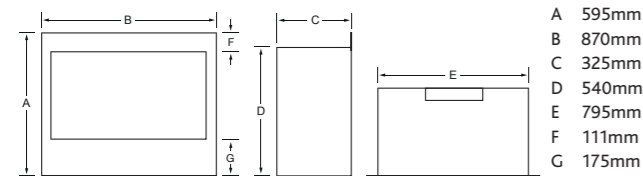

Dimensions for the Eden Balanced Flue model may vary please consult the installation manual for further details.

Slimline fascia

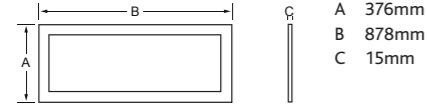

Deluxe fascia

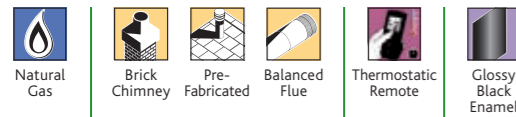
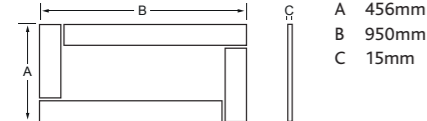

Eden HE with Polished Steel Slimline fascia and white stones. Also available in Antique Brass



Eden HE Deluxe Antique Brass fascia with logs



Watch the video

Eden HE balanced flue



Watch the video

Eden HE conventional flue trimless with logs





Eden Elite

The Eden Elite is our slimmest hole-in-the-wall gas fire with up to 85.6% energy efficiency and an impressive 4.9kW heat output. It is operated by a thermostatic remote control system to perfectly control your comfort.

The conventional flue model is designed to be easily installed into almost any chimney without compromising on the stunning log fuel bed and flame aesthetics. It comes in a choice of cream vermiculite or glossy black enamel back panel.

There is also a slimline balanced flue model for homes without a chimney or flue which is only available with a glossy black enamel back panel.

The Eden Elite fire can be fitted without a trim for a sleek minimalist appearance or purchased with an optional brushed steel, or black powder coat trim.

Specifications

Description: Slimline inset gas fire
Type of Heat: Radiant & Convected

	Conventional flue	Balanced flue
Useful energy efficiency	78.6%	85.6%
Energy efficiency class	D	C
Fuel type	Natural gas	Natural gas
Direct heat output	4.9kW	3.7kW

Fuel Effect	Back Panel	Model Number	
Log	Glossy Black	KEEELRN	KEELOORN
	Cream Vermiculite	KEELVRN	n/a

Safety: Flame Supervision Device & Oxygen Depletion Sensor
Air vent required: Not normally

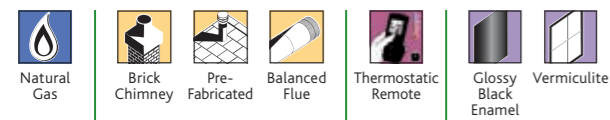
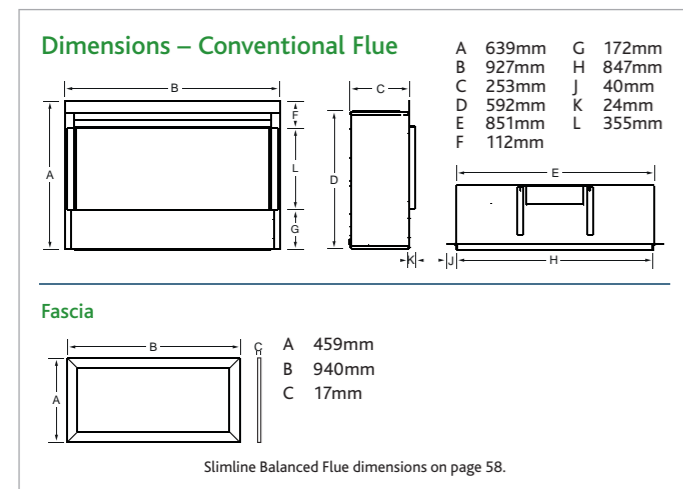

Eden Elite with brushed steel trim and glossy black enamel panels



Eden Elite with cream vermiculite tiled effect back panel and black powder coat trim



Watch the video
Eden Elite Slimline conventional flue



Watch the video
Eden Elite Slimline BF with glossy black enamel back panel and black powder coat trim



Passion HE

Passion HE is a beautiful gas fire with a truly authentic looking log effect fuel bed. With its large viewing window it features stunning flame motion that captivates as it dances and reflects in the glossy black enamel interior.

For optimum comfort and performance this product features a fully automatic remote control with thermostat. A manual control option is also available.

The Passion HE is available with a choice of specifically designed contemporary one-piece fascia options, the Ultimo 007 in three colour finishes, gold, black nickel and silver, and the Provence cast iron fascia in black.

For a more traditional two-piece arrangement we have introduced a uniquely designed Bauhaus 151 fret. Combine this with the tasteful Ultimo trim to further complement the wide viewing angles of this fire. Alternatively you can combine this fret with other Kinder trim options – see page 57.

Specifications

Description: Full depth inset gas fire
Type of Heat: Radiant & Convected

	Manual	Remote
Useful energy efficiency	82.3%	82.6%
Energy efficiency class	D	C
Fuel type	Natural gas	Natural gas
Direct heat output	4.0kW	4.0kW

Fuel effect	Model Number
Log	KLBL00MN KLBL0ORN

Safety: Flame Supervision Device & Oxygen Depletion Sensor
Air vent required: Not normally

Dimensions

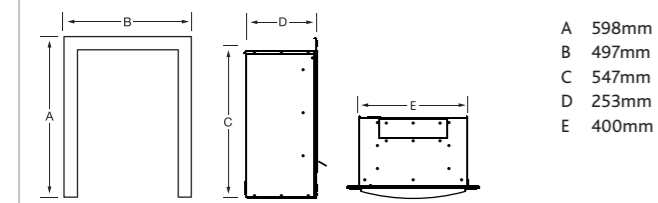

- A 598mm
- B 497mm
- C 547mm
- D 253mm
- E 400mm

Dimensions A & B refer to standard trims only.

Passion Fascias

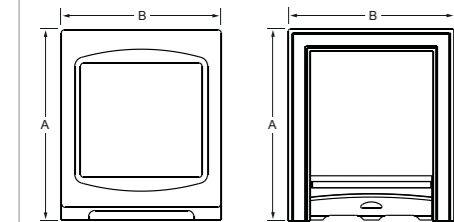

Provence*
A 614mm
B 532mm

Ultimo 007
A 613mm
B 516mm

*Remote control option only.

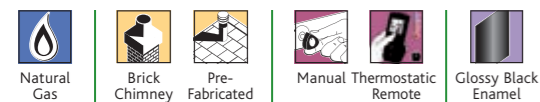

Passion HE with Ultimo 007 fascia in Gold. Also available in Black Nickel and Silver



Passion HE Ultimo trim and Bauhaus 151 in Silver. Also available in Gold finish.



Passion HE Ultimo trim and Bauhaus 151, shown in Black Nickel. Also available in Gold finish.



Watch the video

Passion HE with Provence black cast iron fascia (available with remote control only)



Nevada HE

This slimline high efficiency fire boasts an energy efficiency of up to 81.3% and will fit almost any chimney or flue including Pre-Cast (BS EN 1858).

With a choice of coal or pebble* fuel bed the Nevada HE also features a large viewing window and an incredible 2.9kW heat output. Create your own style with a choice of trim or fret combination from the extensive range on pages 56 to 57.

*Available to purchase as an optional extra.

Specifications

Description: Slimline inset gas fire
Type of Heat: Radiant & Convected

Useful energy efficiency	81.3%
Energy efficiency class	D
Fuel type	Natural gas
Direct heat output	2.9kW

Fuel effect	Control type	Model Number
Coal	Manual	KSHC00MN
	Slide	KSHC00SN2

Safety: Flame Supervision Device & Oxygen Depletion Sensor
Air vent required: Not normally

Dimensions

A 598mm
B 497mm
C 550mm
D 125mm
E 327mm

Dimensions A & B refer to standard trims only.

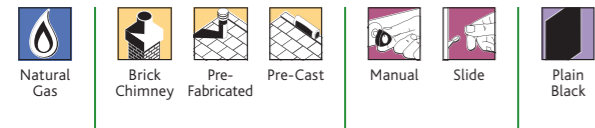

Nevada HE with pebble* fuel effect, Standard trim and Athena fret in a polished silver finish.



Nevada HE with coal fuel effect, Standard trim and Athena fret in a brass finish



Kalahari HE

With an energy efficiency of 84.3%, the Kalahari HE has been designed to fit most flue types including pre-cast flues when installed with a 3" rebated fire surround.

As well as manual or slide control options you can also enjoy the luxury of a fully remote control system on the Kalahari HE. Comes with coal fuel effect as standard. A pebble fuel bed pack is available as an optional extra. Choose any trim and fret combination from the Kinder fascia range on pages 56 to 57 to complement your living area.

Specifications

Description: Full depth inset gas fire
Type of Heat: Radiant & Convected

	Manual/Slide	Remote
Useful energy efficiency	84.3%	84.3%
Energy efficiency class	D	C
Fuel type	Natural gas	Natural gas
Direct heat output	3.4kW	3.4kW

Fuel effect	Control type	Model Number	
Coal	Manual	KHKC00MN2	n/a
	Slide	KHKC00SN2	n/a
	Remote	n/a	KHKC00RN3

Safety: Flame Supervision Device & Oxygen Depletion Sensor
Air vent required: Not normally

Dimensions

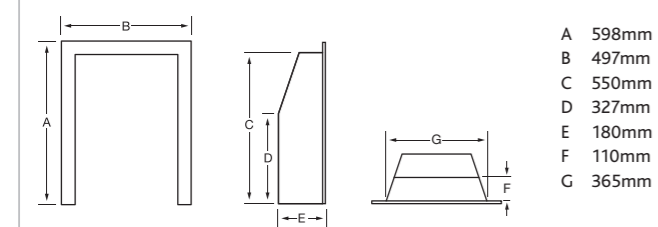

- A 598mm
- B 497mm
- C 550mm
- D 327mm
- E 180mm
- F 110mm
- G 365mm

Dimensions A & B refer to standard trims only.

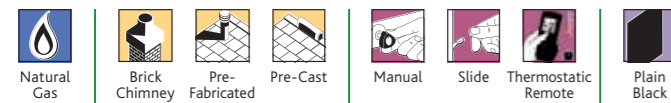

Kalahari HE with pebble fuel effect, Chamfered trim and Athena fret in a polished silver finish.



Kalahari HE with coal fuel effect, Chamfered trim and Athena fret in a polished silver finish

Camber HE

The stylish silver fascia combined with a black back panel and coal fuel bed make the Camber HE a welcome centre-piece in any modern living room.

Boasting an energy efficiency of 84.3% the Camber HE is economical as well as eye-catching. It is also suitable for most conventional flue chimneys including pre-cast when installed with a 3" rebated fire surround.

An optional pebble fuel bed pack may be purchased separately.

Specifications

Description: Full depth inset gas fire
Type of Heat: Radiant & Convected

Useful energy efficiency	84.3%	84.3%
Energy efficiency class	D	C
Fuel type	Natural gas	Natural gas
Direct heat output	3.4kW	3.4kW

Fuel effect	Control type	Model Number	
Coal	Manual	KHKC00MN2	n/a
	Slide	KHKC00SN2	n/a
	Remote	n/a	KHKC00RN3





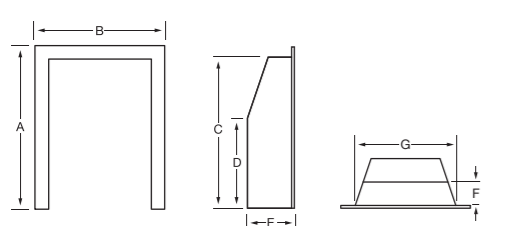



Safety: Flame Supervision Device & Oxygen Depletion Sensor
Air vent required: Not normally

Dimensions



- A 610mm
- B 520mm
- C 550mm
- D 327mm
- E 180mm
- F 110mm
- G 365mm

Dimensions A & B refer to standard trims only.

-  Natural Gas
-  Brick Chimney
-  Pre-Fabricated
-  Pre-Cast
-  Manual
-  Slide
-  Thermostatic Remote
-  Plain Black



Camber HE with pebble fuel effect.



high efficiency Conventional Flue

Hearth Inset – Glass Fronted



Oasis HE

Based on our most popular hearth mounted fire, the Oasis HE is the first model in the Kinder 'high efficiency' range.

The Oasis HE has an incredible energy efficiency of 86.3% and 4.0kW heat output, ensuring that this fire gives optimum heat combined with cost efficiency. This glass fronted product is available with all Kinder trim and fret combinations allowing you to personalise the look and style of your fire – see pages 56 to 57 for options.

Specifications

Description: Full depth inset gas fire.
Type of Heat: Radiant & Convected

Useful energy efficiency	86.0%
Energy efficiency class	C
Fuel type	Natural gas
Direct heat output	3.9kW

Fuel effect	Control type	Model Number
Coal	Manual	KHEC00MN
	Slide	KHEC00SN
	Remote	KHEC00RN2

Useful energy efficiency	86.3%
Energy efficiency class	C
Fuel type	LPG
Direct heat output	4.0kW

Fuel effect	Control type	Model Number
Coal	Slide	KHEC00SP

Safety: Flame Supervision Device & Oxygen Depletion Sensor
Air vent required: Not normally

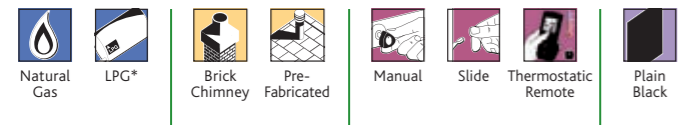
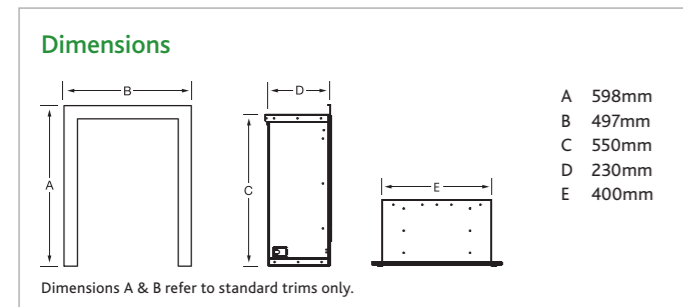

*Only available on slide control model.





Avignon Celena Suite

The Avignon Gas Fire Suite is beautifully crafted in natural Portuguese Limestone, combining traditional style and modern taste into one classically designed fireplace.

Featuring the beautiful conventional flue Celena gas fire which is a highly efficient glass fronted fire designed to be suitable for homes with a brick chimney or pre-fabricated flue.

The slimline balanced flue option boasts an impressive 90.5% energy efficiency rating with a direct heat output of 3.9kW. This model features an attractive lower level log fuel arrangement whilst the conventional flue option has a raised log fuel bed and has an energy efficiency of 79.6%.

A thermostatic remote control system allows you to pre-set your desired room temperature. Fire interior panels are available in a choice of matt black enamel or cream vermiculite.

Specifications

Description: Full depth inset gas fire
Type of Heat: Radiant & Convected

	Conventional flue	Balanced flue
Useful energy efficiency	79.6%	90.5%
Energy efficiency class	D	B
Fuel type	Natural gas	Natural gas
Direct heat output	3.9kW	3.9kW

Fuel Effect	Back Panel	Model Number	
Log	Matt Black	KPRLPBRN810	KCBLPBRN720
	Cream Vermiculite	KPRLTVRN810	KCBLTVRN720

Safety: Flame Supervision Device & Oxygen Depletion Sensor
Air vent required: Not normally

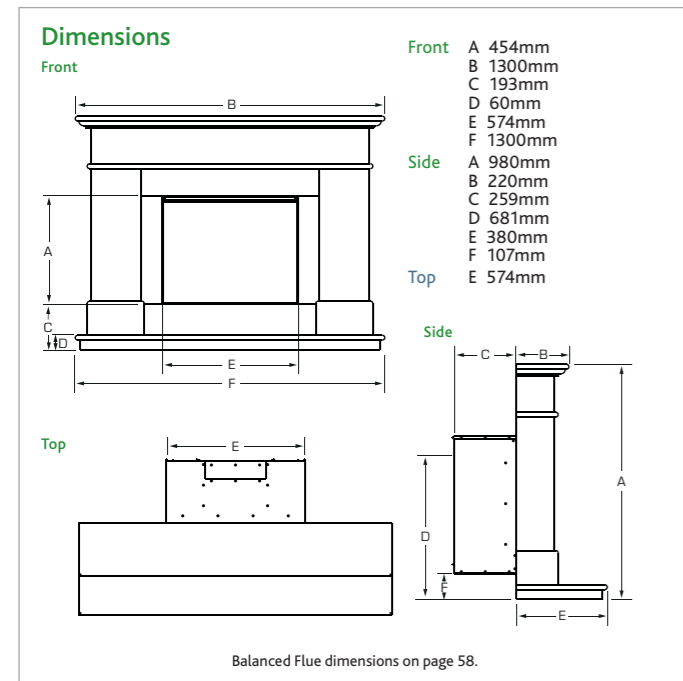

Avignon Suite & Celena gas fire with cream vermiculite fire back



Avignon Suite & Celena BF gas fire with matt black enamel fire back panels

- Natural Gas
- Brick Chimney
- Pre-Fabricated
- Balanced Flue
- Thermostatic Remote
- Matt Black Enamel
- Cream Vermiculite



Lille Celena Suite

The Lille fire surround suite is made from the finest quality Portuguese limestone in a contemporary design that features a chamfered recess frame designed to draw the eye into a large viewing area with its attractive display of tall lively flames.

It comes with the stunning Celena gas fire. This glass fronted fire features a beautiful raised style log effect fuel bed and has an incredible 79.6% energy efficiency. It is operated by a fully automatic remote control system which allows you to select the times you want the fires to automatically turn on and turn off and includes a thermostatic setting to allow you to pre-set your desired room temperature.

It is suitable for installation into most standard chimneys and has a choice of matt black enamel or cream vermiculite back panels.

Specifications

Description: Full depth inset gas fire
Type of Heat: Radiant & Convected

Useful energy efficiency	79.6%
Energy efficiency class	D
Fuel type	Natural gas
Direct heat output	3.9kW

Fuel Effect	Back Panel	Model Number
Log	Matt Black	KPRLPBRN695
	Cream Vermiculite	KPRLTVRN695

Safety: Flame Supervision Device & Oxygen Depletion Sensor
Air vent required: Not normally

Dimensions

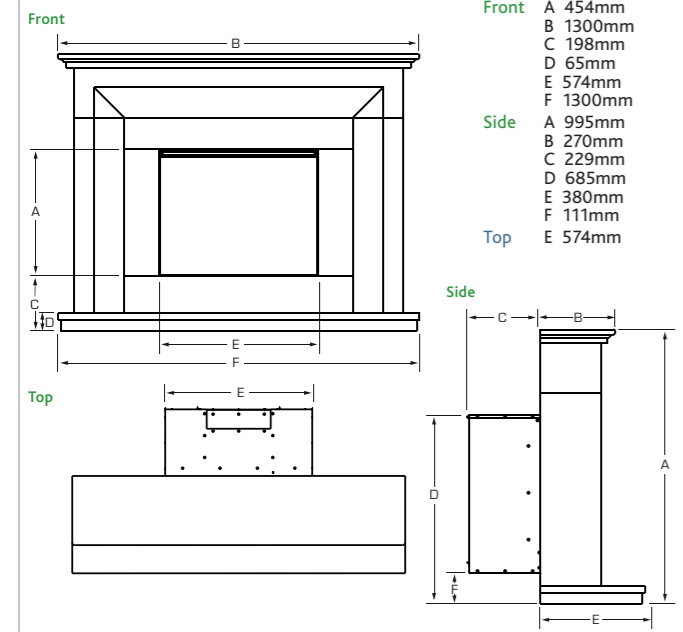

Watch the video

Lille Suite & Celena gas fire with matt black enamel back panels

- Natural Gas
- Brick Chimney
- Pre-Fabricated
- Thermostatic Remote
- Matt Black Enamel
- Cream Vermiculite

Rennes Celena Suite

The Rennes Gas Fire Suite features a sleek, modern design which is perfect for a more minimalist appearance and is made from the finest quality Portuguese limestone.

It comes complete with the perfectly proportioned Celena gas fire which is a highly efficient, glass fronted fire featuring a stunning raised style log effect fuel bed, a direct heat output of 3.9kW and 79.6% energy efficiency. It is suitable for installation into most standard brick chimneys and pre-fabricated flues.

It is also operated by a fully automatic remote control system which allows you to select the times you want your fire to automatically turn on and turn off and includes a thermostatic setting to allow you to pre-set your desired room temperature.

Specifications

Description: Full depth inset gas fire
Type of Heat: Radiant & Convected

Useful energy efficiency	79.6%
Energy efficiency class	D
Fuel type	Natural gas
Direct heat output	3.9kW

Fuel Effect	Back Panel	Model Number
Log	Matt Black	KPRLPBRN790
	Cream Vermiculite	KPRLTVRN790

Safety: Flame Supervision Device & Oxygen Depletion Sensor
Air vent required: Not normally

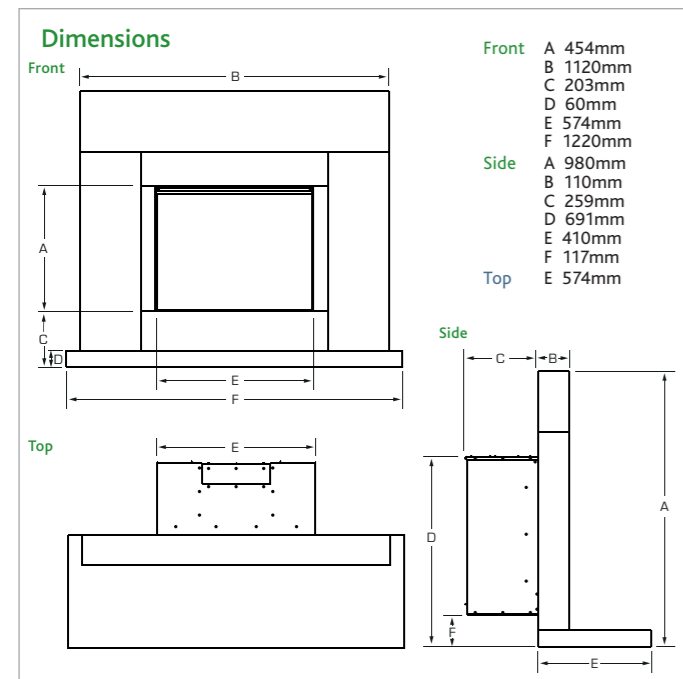

Watch the video

Rennes Suite & Celena gas fire with matt black enamel back panels



Avignon Eden Elite Suite

This stunning fireplace suite comprises the classically styled Avignon surround in 54" or 58" wide versions, is made from high quality natural Portuguese limestone and includes the fabulous Eden Elite gas fire.

The slimline balanced flue option is suitable for installation into homes without a brick chimney or pre-fabricated flue and has an impressive energy efficiency of 85.6% and 3.7kW heat output. It features a glossy black enamel back panel.

The conventional flue option comes with a choice of glossy black enamel or cream vermiculite back panels and features a stunningly realistic raised log fuel bed. It has an energy efficiency of 78.6% and impressive heat output of 4.9kW.

Both models are operated by a fully automatic and thermostatic remote control system so you can maintain a comfortable room temperature at the touch of a button.

Specifications

Description: Full depth inset gas fire
Type of Heat: Radiant & Convected

	Conventional flue	Balanced flue
Useful energy efficiency	78.6%	85.6%
Energy efficiency class	D	C
Fuel type	Natural gas	Natural gas
Direct heat output	4.9kW	3.7kW

Fuel Effect	Back Panel	Model Number	
Log	Glossy Black 54"	KEELELRN890	KBELEBRN722
	Cream Vermiculite 54"	KEELVLRN890	n/a
	Glossy Black 58"	KEELELRN910	KBELEBRN779
	Cream Vermiculite 58"	KEELVLRN910	n/a

Safety: Flame Supervision Device & Oxygen Depletion Sensor
Air vent required: Not normally

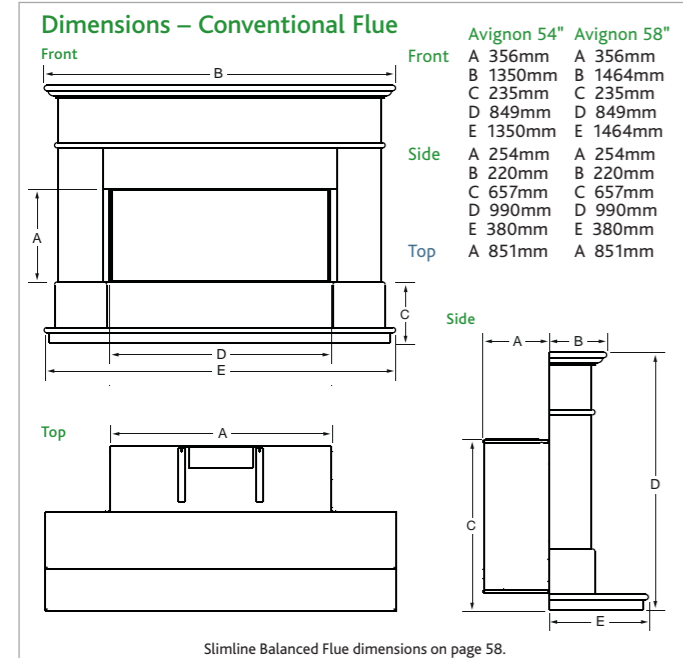

- Natural Gas
- Brick Chimney
- Pre-Fabricated
- Balanced Flue
- Thermostatic Remote
- Glossy Black Enamel
- Cream Vermiculite



Avignon 58" Eden Elite conventional flue with cream vermiculite tiled effect back panels



Avignon 54" Eden Elite Slimline balanced flue with glossy black enamel back panels

high efficiency Conventional Flue

Hearth Inset – Open Fronted



Nevada Plus

The Nevada Plus is one of the most efficient open-fronted slimline gas fires available today and with a heat output of up to 4.0kW it is also one of the warmest products suitable for a pre-cast flue.

The Nevada Plus is available in a choice of manual, remote or our easy access Easy Flame control systems. This extremely versatile fire can be styled with a wide range of Kinder trims, frets or fascias and with an optional pebble fuel bed it is easy to create a look to suit your existing décor. See pages 56 to 57 for more information about Kinder accessories.

Specifications

Description: Full depth inset gas fire
Type of Heat: Radiant & Convected

	Manual	EFC/Remote
Useful energy efficiency	66.8%	66.8%
Energy efficiency class	F	F
Fuel type	Natural gas	Natural gas
Direct heat output	4.0kW	3.8kW

Fuel effect	Control type	Model Number	
Coal	Manual	KSPC00MN	n/a
	EFC	n/a	KSPC00TN2
	Remote	n/a	KSPC00RN2

Safety: Flame Supervision Device & Oxygen Depletion Sensor
Air vent required: Not normally

Dimensions

Dimensions A & B refer to standard trims only.

- A 600mm
- B 498mm
- C 548mm
- D 125mm
- E 324mm

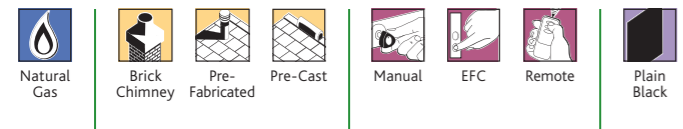

Nevada Plus with Profiled trim in silver and Bauhaus fret in polished silver with pebble fuel effect.



Nevada Plus with Profiled trim in brass and Dallas fret in brass with coal fuel effect
Watch the video

high efficiency Conventional Flue

Hearth Inset – Open Fronted



Kalahari Plus

The Kalahari Plus high efficiency gas fire boasts an impressive 68.3% energy efficiency and can be installed in to almost any chimney or flue, including Pre-cast when fitted with a 3" rebated fire surround.

This open-fronted gas fire features a highly realistic coal fuel effect and is available as a manual, slide or remote controlled fire. Comes with coal fuel effect as standard. A pebble fuel bed pack is available as an optional extra.

The Kinder Kalahari can be styled with most trims, frets and fascias in our wide range of gas fire accessories on pages 56 to 57.

Specifications

Description: Full depth inset gas fire
Type of Heat: Radiant & Convected

Useful energy efficiency	68.3%
Energy efficiency class	F
Fuel type	Natural gas
Direct heat output	4.2kW

Fuel effect	Control type	Model Number
Coal/Pebble	Manual	KKPC00MN
	Slide	KKPC00SN
	Remote	KKPC00RN2

Useful energy efficiency	67%
Energy efficiency class	F
Fuel type	LPG
Direct heat output	4.2kW

Fuel effect	Control type	Model Number
Coal	Manual	KKPC00SP

Safety: Flame Supervision Device & Oxygen Depletion Sensor
Air vent required: Not normally

Dimensions

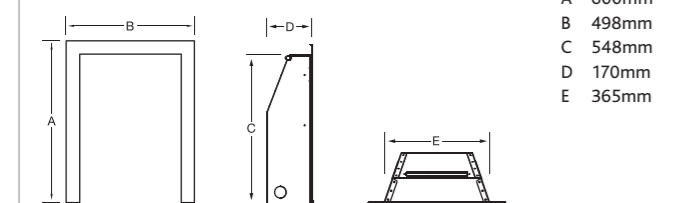

- A 600mm
- B 498mm
- C 548mm
- D 170mm
- E 365mm

Dimensions A & B refer to standard trims only.

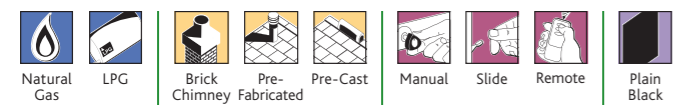

Kalahari Plus with pebble fuel effect, Designer trim in silver & black and Vegas fret in polished silver.



Kalahari Plus with coal fuel effect, Designer trim in silver & black and Vegas fret in polished silver



Camber Plus

The Camber Plus is certainly a contemporary classic with a wonderfully sleek design that will never go out of fashion.

This open-fronted gas fire provides an incredible 4.2kW heat output with an energy efficiency of 68.3%. The Camber Plus is available in both manual and remote control versions and has a black back panel with a beautifully realistic coal fuel bed.

A pebble fuel bed pack can be purchased as an optional extra.

Specifications

Description: Full depth inset gas fire
Type of Heat: Radiant & Convected

Useful energy efficiency	68.3%
Energy efficiency class	F
Fuel type	Natural gas
Direct heat output	4.2kW

Fuel effect	Control type	Model Number
Coal	Manual	KKPC00MN
	Slide	KKPC00SN
	Fully Remote	KKPC00RN2

Safety: Flame Supervision Device & Oxygen Depletion Sensor
Air vent required: Not normally

Dimensions

A 610mm
B 520mm
C 548mm
D 170mm
E 365mm

Dimensions A & B refer to standard trims only.

- Natural Gas
- Brick Chimney
- Pre-Fabricated
- Pre-Cast
- Manual
- Remote
- Plain Black



Camber Plus with pebble fuel effect.



Watch the video

Camber Plus with coal fuel effect

high efficiency Conventional Flue

Hearth Inset – Glass Fronted



Oasis Plus

The Oasis Plus is the first full depth open-fronted high efficiency gas fire from Kinder. You can now achieve the look of a real open coal fire, combined with the convenience of gas fuel, at an incredible 66.7% energy efficiency.

This stunning fire features an extra wide coal fuel effect bed, a beautiful flame picture and offers an incredible 4.2kW heat output.

Suitable for installation into standard brick chimneys and pre-fabricated flues, the Oasis Plus comes in a choice of manual, slide or remote control and can be styled to suit your home with our wide range of trims and frets (see pages 56 to 57 for further details).

Specifications

Description: Full depth inset gas fire
Type of Heat: Radiant & Convected

Useful energy efficiency	66.7%
Energy efficiency class	F
Fuel type	Natural gas
Direct heat output	4.1kW

Fuel effect	Control type	Model Number
Coal	Manual	KOPC00MN
	Slide	KOPC00SN
	Remote	KOPC00RN2

Useful energy efficiency	66.2%
Energy efficiency class	F
Fuel type	LPG
Direct heat output	4.2kW

Fuel effect	Control type	Model Number
Coal	Slide	KOPC00SP

Safety: Flame Supervision Device & Oxygen Depletion Sensor
Air vent required: Not normally

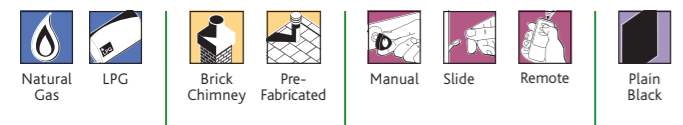
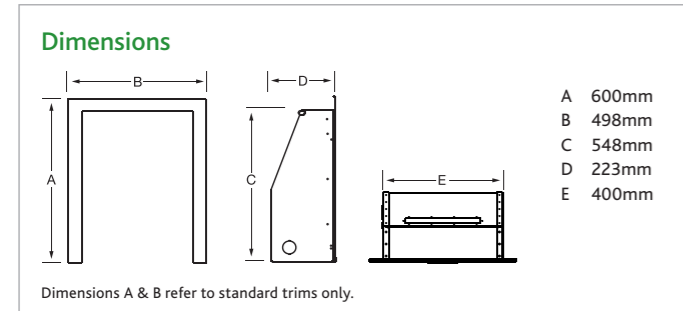

Oasis Plus with Camber Champagne fascia. Not available on SC models.



Oasis Plus with Designer trim in black & brass and Vegas fret in antique brass 43

high efficiency Conventional Flue

Hearth Inset – Open Fronted



Oasis

The Oasis successfully marries classic looks with state-of-the-art performance and is currently one of the warmest open-fronted convector fires with a heat output of up to 3.7kW.

The full depth fuel bed and highly realistic coal effect provides a mesmerising flame picture with a cosy glow ensuring an attractive centrepiece in any room. There is also a low lintel option available, along with a wide choice of trim and fret combinations in contemporary or traditional styles. See pages 56 to 57 for details.

Specifications

Description: Full depth inset gas fire
Type of Heat: Radiant

Useful energy efficiency	60.0%
Energy efficiency class	F
Fuel type	Natural gas
Direct heat output	3.7kW

Fuel effect	Control type	Model Number
Coal	Manual	KICCO0MN
	Slide	KICCO0SN

Safety: Flame Supervision Device & Oxygen Depletion Sensor
Air vent required: Not normally

Dimensions

Oasis
 A 594mm
 B 485mm
 C 550mm
 D 250mm
 E 400mm

Oasis Low Lintel
 A 544mm
 B 485mm
 C 500mm
 D 270mm
 E 400mm

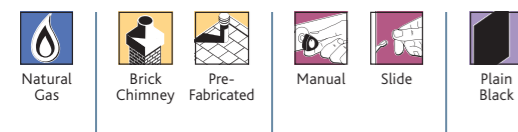



Dakota BF

The Dakota's stylish glass front is instantly eye-catching and helps ensure incredible efficiency.

As the Dakota is designed exclusively as a balanced flue model, home owners without a chimney can still enjoy the benefits of having a Kinder gas fire. Comes with the option of a brass, black or silver chamfered trim which can be teamed with any fret from our extensive range on page 57.

Specifications

Description: Full depth inset gas fire
Type of Heat: Radiant & Convected

Useful energy efficiency	80%	
Energy efficiency class	E	
Fuel type	Natural gas	
Direct heat output	2.7kW	
Fuel effect	Control type	Model Number
Coal	Manual	KF70

Safety: Flame Supervision Device & Oxygen Depletion Sensor
Air vent required: Not normally

Dimensions

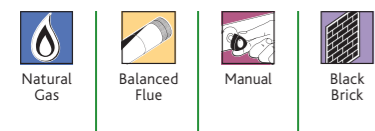
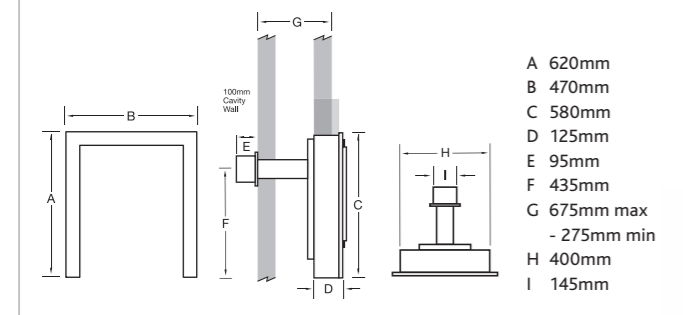

Dakota BF with Vegas fret in a black finish.



Dakota BF with Vegas fret in a polished silver finish.



Dakota BF with Vegas fret in a brass finish 47

high efficiency Balanced Flue

Hearth Inset – Glass Fronted



Revolution BF

Designed to fit into a standard cavity wall with a 3" rebated surround the Revolution Balanced Flue gas fire boasts an energy efficiency of up to 93.5% and features a full depth coal fuel effect.

The Revolution is available in manual, remote or with a fully automatic Easy Flame control option with discreet, easy access buttons which ignites the fire and allows you to adjust the heat and flame height to suit your needs.

This glass fronted fire has an exceptionally large viewing area and can be styled with a variety of trims and frets available from the Kinder accessories range on pages 56 to 57.

Specifications

Description: Full depth inset gas fire
Type of Heat: Radiant & Convected

Useful energy efficiency	93.5%
Energy efficiency class	B
Fuel type	Natural gas
Direct heat output	3.9kW

Fuel effect	Control type	Model Number
Coal	Manual	KBFC00MN2
	EFC	KBFC00EN3
	Remote	KBFC00RN3

Useful energy efficiency	93.5%
Energy efficiency class	B
Fuel type	LPG
Direct heat output	4.0kW

Fuel effect	Control type	Model Number
Coal	Manual	KBFC00MP2

Safety: Flame Supervision Device & Oxygen Depletion Sensor
Air vent required: Not normally

Dimensions

A 598mm
B 497mm
C 551mm
D 185mm
E 486mm
F 406mm
G 150mm
H 423mm
I 120mm
J 285mm min
- 625mm max*

*Dimensions differ on EFC models. An optional flue duct extension is available for natural gas models only to increase maximum length to 1015mm on manual models and 973mm on EFC models.

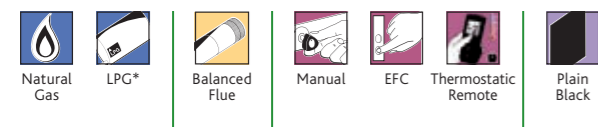

*Only available with Manual Control as a converter kit.





Nevada

With its ultra slim design, the Nevada will fit beautifully into almost any fireplace and is also available in a powerflue version for homes without a chimney or flue.

With the natural ambient glow of real-effect coals and flames, it will suit your lifestyle and your home perfectly. A pebble fuel bed pack is available as an optional extra and you can create your own look by choosing a trim and fret combination from our extensive range on pages 56 to 57.

Specifications

Description: Full depth inset gas fire
Type of Heat: Radiant

	Conventional	Powerflue
Useful energy efficiency	53.1%	55.2%
Energy efficiency class	F	F
Fuel type	Natural gas	Natural gas
Direct heat output	3.1kW	3.2kW

Fuel effect	Control type	Model Number	
Coal/Pebble	Manual	KNVC00MN	KVNC00MN
	Slide	KNVC00SN	n/a

Safety: Flame Supervision Device & Oxygen Depletion Sensor
Air vent required: Not normally

Dimensions

A 598mm
B 497mm
C 550mm
D 325mm
E 100mm

For Powerflue dimensions please see page 59.
Dimensions A & B refer to Standard trims only.

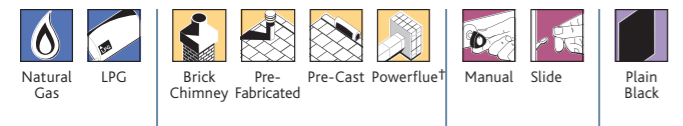

†Available in Manual Control only.



Nevada with optional pebble fuel effect, Designer trim in black and silver and Dallas fret in polished fret.



Nevada with coal fuel effect, Designer trim in black & brass and Dallas fret in antique brass finish. 51



Kalahari & Black Magic

The Kalahari instantly brings a room to life. This market leading radiant offers the appearance of a real open fire and incorporates a full-depth ceramic coal fuel effect for beautifully realistic flames and an inviting charm.

Designed to fit snugly into a pre-cast flue with a 3" rebated fire surround, this fire exudes a welcoming heat output of up to 3.3kW. The Kalahari is available in a choice of manual, slide or fully automatic remote control. A pebble fuel bed pack is available as an optional extra.

The Black Magic features a contemporary fascia which is made from high quality extruded aluminium and comes in a beautiful black textured paint finish.

Specifications

Description: Full depth inset gas fire
Type of Heat: Radiant

Fuel type	Natural gas
Direct heat output	2.7kW

Fuel effect	Control type	Model Number
Coal/Pebble	Manual	KRDC00MN630
	Slide	KRDC005N

This product is not suitable for primary heating purposes

Powerflue	
Useful energy efficiency	57.2%
Energy efficiency class	F
Fuel type	Natural gas
Direct heat output	3.6kW

Fuel effect	Control type	Model Number
Coal/Pebble	Manual	KVPC00MN630

Safety: Flame Supervision Device & Oxygen Depletion Sensor
Air vent required: Not normally

Dimensions

Kalahari
A 598mm*
B 497mm*
C 550mm
D 327mm
E 170mm
F 110mm
G 365mm
Black Magic
A 610mm
B 520mm
C 550mm
D 327mm
E 170mm
F 110mm
G 365mm

For Powerflue dimensions please see page 59.
*Dimensions A & B refer to Standard trims only.



Kalahari with pebble fuel effect, Designer trim and Bauhaus fret in a silver finish.



Black Magic with black textured paint finish.



†Only available with Manual Control. Ecodesign Compliant on Powerflue model only.
* Not available with Black Magic fascia.



Kalahari & Black Magic conventional flue



Kalahari with Arcadia fascia in silver



Camber

The Camber with its striking looks, clean design lines and highly realistic blazing dancing flames will captivate you on entering the room.

This fire is precision manufactured and, with its deep coal fuel bed, provides an individual combination of aesthetic beauty combined with high quality performance.

The Camber features a plain black back panel and a silver fascia. A pebble fuel bed alternative is available as an optional extra.

Specifications

Description: Full depth inset gas fire
Type of Heat: Radiant

Fuel type	Natural gas
Direct heat output	2.7kW

Fuel effect	Control type	Model Number
Coal/Pebble	Manual	KRDPW1MN
	Remote	KRDPW1RNZ

Safety: Flame Supervision Device & Oxygen Depletion Sensor
Air vent required: Not normally
This product is not suitable for primary heating purposes

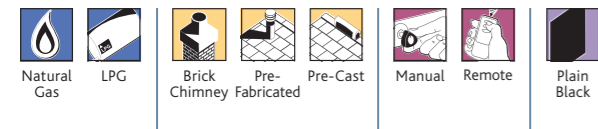
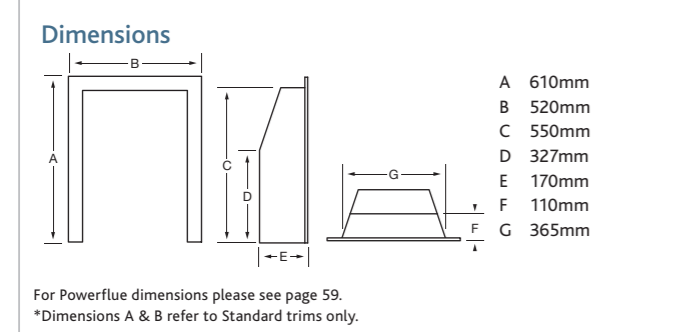

Camber with pebble fuel effect.



Finishing touches

Beautiful companions for your Kinder gas fire – choose from our wide range of fascias, trims & frets.

Trims

Designer trim Made from extruded anodised aluminium, Designer trims create fabulous dual-coloured looks in a choice of six combinations. Suitable for the Nevada Plus, Kalahari Plus, Oasis Plus, Nevada HE, Kalahari HE, Oasis HE, Nevada, Kalahari and Oasis† fires.



Standard trim

Quality steel trims in a choice of four colours with a plated or painted finish. Suitable for the Nevada Plus, Kalahari Plus, Oasis Plus, Nevada HE, Kalahari HE, Oasis HE, Nevada, Kalahari, Oasis, Oasis LL†† and Revolution fires.



Ultimo trims



The Ultimo is a cast iron trim with a black painted and optional colour plated finish. Suitable for Nevada Plus, Kalahari Plus, Oasis Plus, Nevada HE, Kalahari HE, Oasis HE, Nevada, Kalahari and Oasis† fires.

Chamfered trim

Made from steel in a choice of two plated finishes. Suitable for the Nevada Plus*, Kalahari Plus*, Oasis Plus*, Nevada HE*, Kalahari HE*, Oasis HE*, Nevada*, Kalahari*, Oasis*, and Revolution fires.



Wide trim

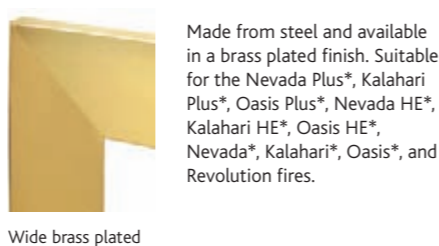

Fascias

The Camber and Black Magic



Camber – brushed satin silver



Camber – brushed satin champagne



Black Magic – black textured paint

The Camber and Black Magic fascias are made from high quality extruded aluminium and are available in anodised silver, and champagne and black painted finish. The Camber and Black Magic fascias are suitable for the Nevada Plus*, Kalahari Plus*, Oasis Plus*, Nevada HE*, Kalahari HE*, Oasis HE*, Passion HET, Nevada*, Kalahari*, Oasis* and Revolution†† fires.

†† Only available with Camber in silver finish.

Arcadia and Embrace



Arcadia gold plated



Arcadia silver plated



Embrace gold plated



Embrace silver plated



Embrace black nickel plated

The Arcadia and Embrace fascias are one-piece cast iron fascias in a combination of black painted with optional colour plated finish. The Arcadia and Embrace are suitable for the Nevada Plus^, Kalahari Plus^, Oasis Plus^, Kalahari HE^, Oasis HE^, Passion HET, Nevada ^, Nevada HE^, Kalahari^, Oasis^ and Revolution†† fires.

^Not available in EFC

Frets

Our extensive range of 18" frets is suitable for most Kinder hearth mounted gas fires. All black, black nickel, gold and polished frets are made from cast iron and all brass frets are made from solid cast brass.

Bauhaus 151*



Bauhaus 151 black nickel plated
*Only suitable for Passion HE models

Bauhaus 151 gold plated

Bauhaus 151 silver plated

Aegis



Aegis black painted



Aegis solid brass



Aegis polished silver

Athena



Athena black painted



Athena solid brass



Athena polished silver

Dallas



Dallas black painted



Dallas solid antique brass



Dallas solid brass



Dallas solid antique silver

Vegas



Vegas black painted



Vegas solid antique brass



Vegas solid brass



Vegas solid antique silver

Bauhaus



Bauhaus black painted



Bauhaus black nickel plated



Bauhaus gold plated



Bauhaus polished silver



Bauhaus silver plated

*Not available for slide control models. † Not available on the low lintel (LL) model †† Only available in brass or black colour options.

*Although suitable for use with the Passion HE the height of the lower bars may compromise viewing of the log fuel effect

Please note that although all frets are suitable for the Passion HE, the height of most frets will compromise the fires viewing area and we recommend the specially designed Bauhaus 151 fret to complement this model.

Balanced flue drawings & dimensions

Celena Balanced Flue Wall Inset
– Page 10

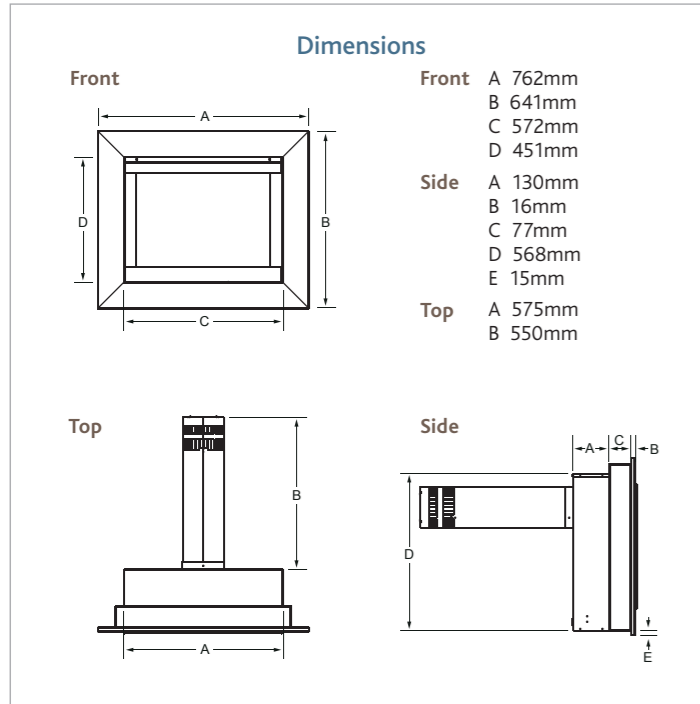

Eden Elite Slimline Balanced Flue Wall Inset
– Page 16

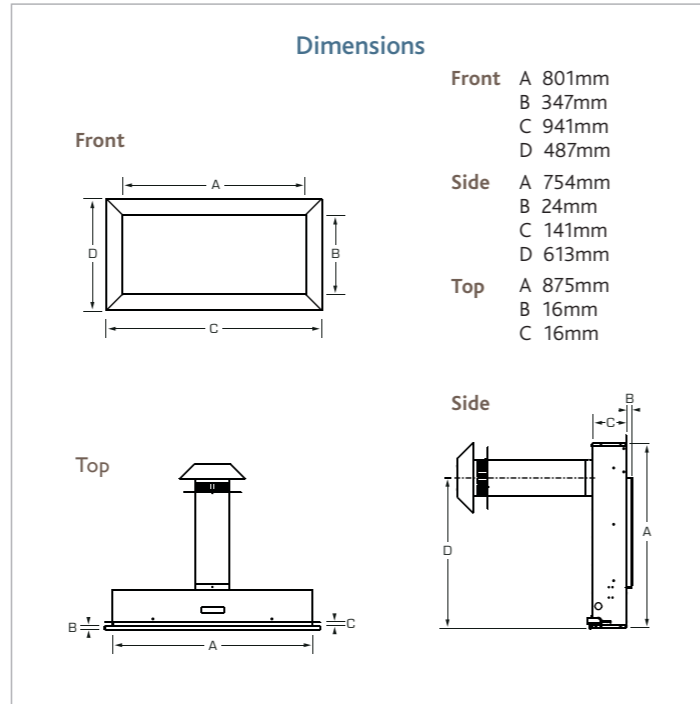

Avignon Celena Balanced Flue Suite
– Page 28

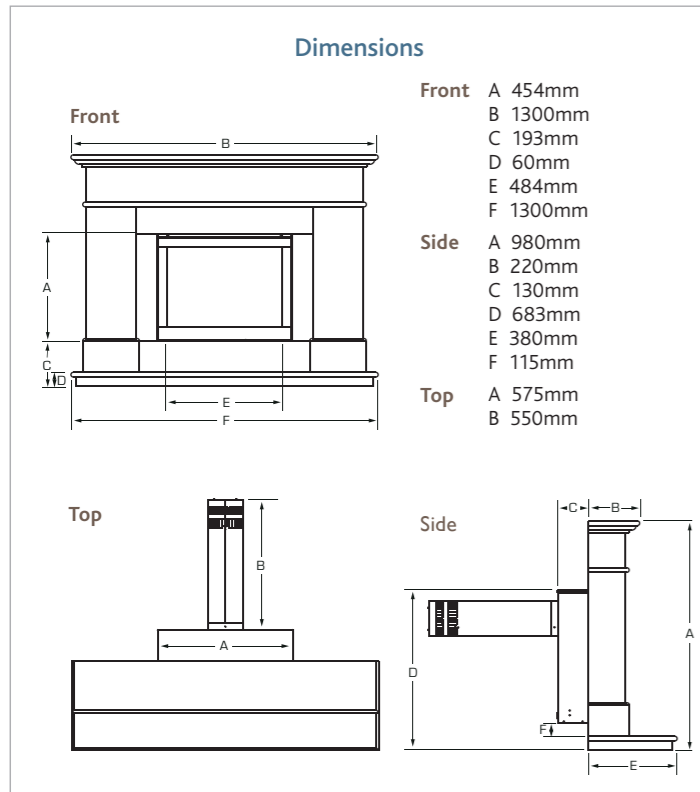

Avignon Eden Elite Slimline Balanced Flue Suite
– Page 34

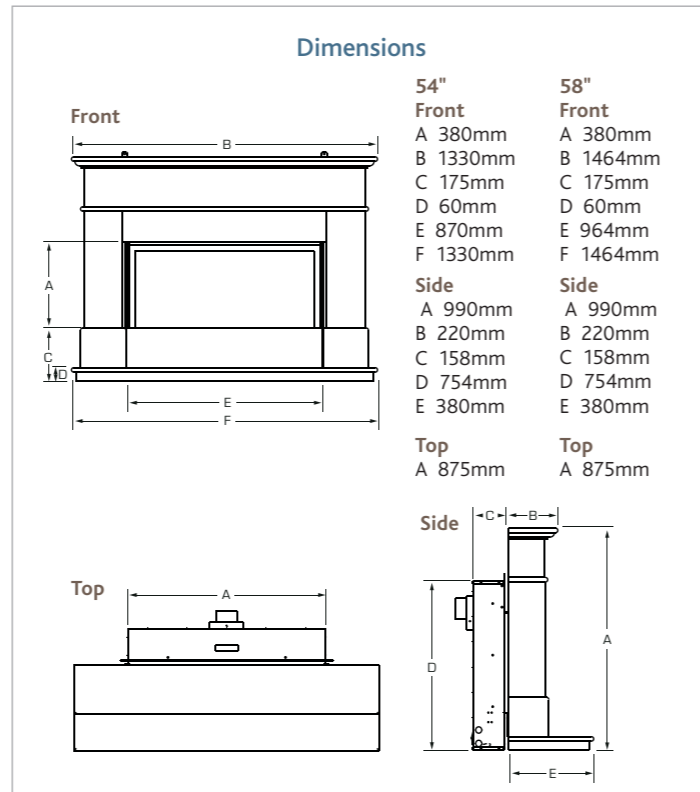

Powerflue installation possibilities

Examples of powerflue installations

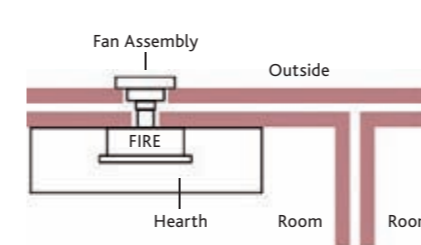

An example of a standard powerflue installation. The gas fire is flued directly through an outside wall via a straight, horizontal length of flue.

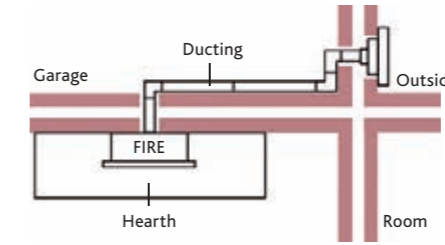

An example of a powerflue installation using three bends.

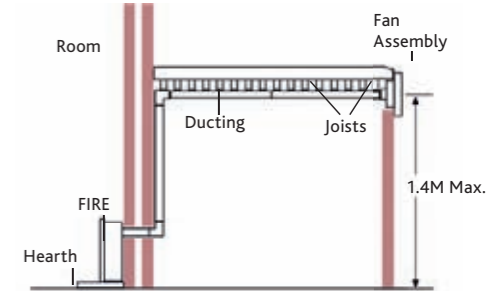

An example of a powerflue installation using a vertical section of flue pipe and two bends.

Kinder powerflue fires



A gas fire creates a welcoming heart to any living room but many newer homes are being built without a chimney or flue so a conventional gas fire is not an option.

However, powerflue (PF) gas fires have been specifically designed for homes without a conventional flue system providing a gas fuelled alternative heat source to an electric fire or radiator. There are two models available as Powerflue versions; the Kalahari and the Nevada.



The Kinder Slimline Fan System fully recessed into an outside wall leaving only a discreet 3" projection. 96mm and 183mm spacers are available if required.

Powerflue installation example

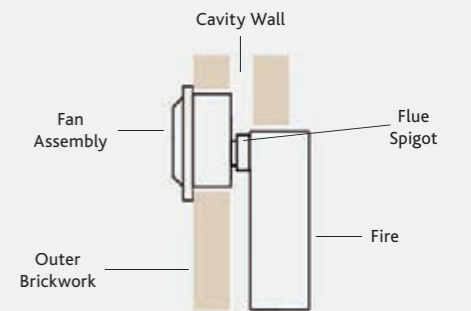

Nevada PF

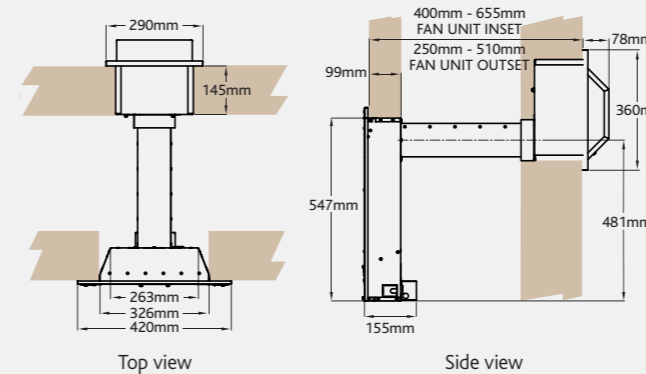

Kalahari MC PF

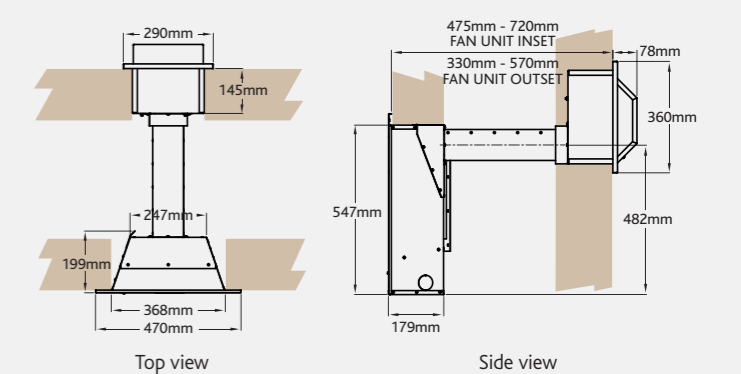

Please note, if required, more detailed information regarding technical specification is available from your Kinder stockist.



M A D E I N B R I T A I N



Find us on Facebook,
Twitter, Pinterest & YouTube



BFM Europe Limited,
Trentham Lakes, Stoke-on-Trent, Staffordshire ST4 4TJ

Telephone: 01782 339000

email: info@bfm-europe.com



www.kindergasfires.co.uk

Go direct to the Kinder website on your smart phone
or tablet device, just scan in this QR code.

IMPORTANT NOTICE

WARNING BFM Europe Limited is a Gas Safe Registered company. We recommend that all of our fires are installed by Gas Safe Register engineers in accordance with our instructions.

DISCLAIMER Our policy is one of constant development and improvement. We therefore reserve the right to revise designs and specifications of our products without formal notice, patents pending. We always recommend our products be viewed in an approved showroom before purchase. Whilst we have taken every care in the preparation of this brochure it is not intended to replace the installation manual which provides more detailed information.

Photography is for illustration purposes only and although every effort has been made to ensure accurate reproduction of typical installations and flame pictures they may vary according to fire model and flue types.

We accept no liability for any loss or damage arising directly or indirectly from the use of this brochure.

We recommend that all our fires are used in conjunction with central heating and not as a primary source of heat.

In the interests of personal safety a suitable fireguard is recommended when children, the elderly and the infirm are present.

(This brochure is copyright 2018 and must not be reproduced in whole or in any part without prior written permission).

With thanks to GB Mantels, Stanningley Firesides and OER Fireplaces for supplying some of the fire surrounds used in this brochure.

